

## TENSION DETECTORS

### MODEL

LX-005TD, LX-015TD, LX-030TD, LX-050TD, LX-100TD, LX-200TD,  
LX-005TD-909, LX-015TD-909, LX-030TD-909, LX-050TD-909,  
LX-100TD-909, LX-200TD-909

## INSTRUCTION MANUAL

- Read through this manual, and use the unit correctly.  
Make sure to understand “Cautions on safety” completely.
- Store this manual carefully, and make sure to send it to the end user.

# TABLE OF CONTENTS



Caution on Safety -----	1
SECTION 2 : Summary of Tension Detector -----	2
SECTION 3 : Installation of tension detector	
3.1 Installing cautions -----	3
3.2 Mounting-----	5
SECTION 4 : Wiring procedue	
4.1 Cautions for wiring-----	7
4.2 Connection between tension detector and controller -	7
SECTION 5 : Operation	
5.1 Cautions for operation -----	7
SECTION 6 : Specifications -----	8
SECTION 7 : Outside dimensions-----	9

# 1. Caution on Safety



(Make sure to read this page before using the tension detector.)



Please read through this instruction manual and other technical data, and handle the tension detector correctly while paying rigid attention to safety.

In this manual, the level of safety precautions are classified into "DANGER" and "CAUTION".

 <b>DANGER</b>	Erroneous handling may cause a dangerous situation in which the possibility of death or serious injury is expected.
 <b>CAUTION</b>	Erroneous handling may cause a dangerous situation in which the possibility of not so serious or slight injury is expected or occurrence of material damages exclusively is expected.

Store this manual carefully so that it can be referred to when required, and make sure to send it to the end user.

 <b>DANGER</b>	Shut down all the phases of the external power supplies during installation and wiring.
	Otherwise, electrical shock or damages in unit may be caused. Make sure to shut down all the phases of the external power supplies before starting installation and wiring.

 <b>DANGER</b>	Never use the tension detector in an atmosphere in which inflammation or explosion is expected.
	Otherwise, inflammation or explosion may be caused.

 <b>CAUTION</b>	Check the environments.
Never install the tension detector in a location in which dust, soot, conductive dust and corrosive gas are present nor a location subject to high temperature, condensation, wind and rain. Never install the tension detector directly in a location on which vibrations or impacts are applied. Otherwise, damages, malfunction or deterioration in the tension detector may be caused.	

## Caution

We shall not be responsible for the damages caused by repair, disassembly, modification or others performed by any third party other than the MITSUBISHI personnel or the personnel specified by MITSUBISHI.

The specifications mentioned in this "Cautions on Safety" and other sections in this instruction manual are subject to change without notice.

## 2. Summary of Tension Detector

This detector is capable of detecting either load of the compression direction and tension direction. You are free to install it to match your own machine. The tension detector is installed basically through the pillow block to the roller which, of the guide rollers as shown in Fig.1, will become the vertex, and converts the material tension into load for detection.

In this case, the load to be applied to the detector, as shown in Fig.1, will become the tension vector sum and the weight of the tension detecting roller will be added thereto.

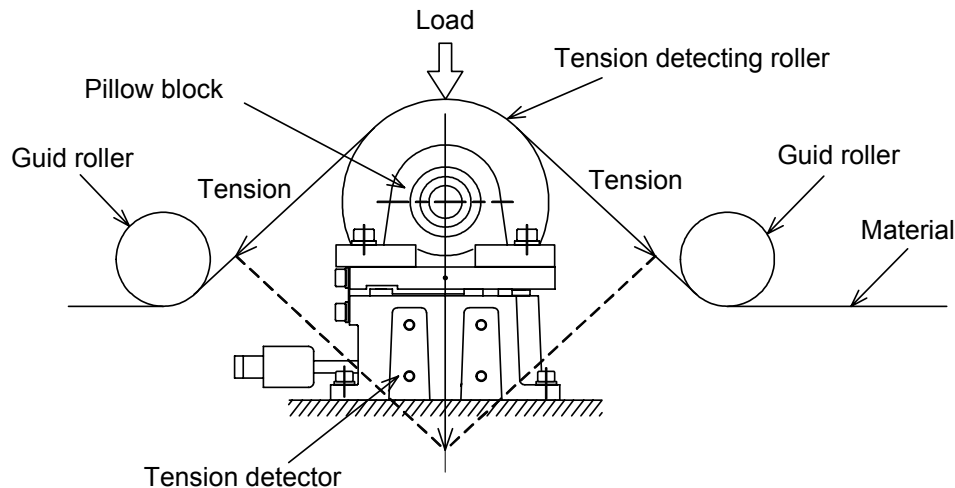

Fig. 1 An example of tension detector installation



In case the material is broad, two detectors are installed as each end of the tension detecting roller to ensure correct detection of the tension over the entire width of the material even if the material is tensed on one side only.



In case the material is narrow, only one detector is used on one side alone, making it possible to allow the automatic aligning type bearing to hold the other end.

## 3. Installation of tension detector



This product is a high sensitivity detector manufactured by precision processing and assembling technology, and should be installed and handled with greatest care.

### 3.1 Installing cautions

 DANGER	Do not use the standard product in flammable or explosive atmosphere.
	It may lead to an explosion if operated without using explosion-proof type and safety barrier. Never use in flammable or explosive atmosphere with oil, grease, flammable gas or the like, Use the intrinsic safety explosion-proof type together with our specified safety barrier.

 DANGER	Turn off the power source, and make sure the rotating element is stopped still.
	Working while the power is supplied causes electric shock or injury. When mounting, dismounting, adjusting, or servicing, turn off the power source of the device beforehand, and make sure the rotating element is stopped still. At this time, be careful not to have the hand or fingers caught in the moving or rotating parts.

 DANGER	Tighten and lock the bolts to specified torque completely.
	Bolts may be sheared and broken to cause injury if not tightened sufficiently. Lock the bolts with adhesive or spring washer to prevent from loosening securely.

 DANGER	Do not drop sawdust or wire chips into product.
	Or it may lead to product damage, smoking, firing, or other danger.

 CAUTION	Do not suspend product by lead wire.
	Or the lead wire may be broken, and the product may fall to cause injury. Mount and dismount by holding the product directly.

(1) Use the bearing of self-aligned type so that imbalance of the tension detecting roller, defective parallelism of mounting surface, other machining error, length change of roller due to temperature change or the like may not be detected as tension. To minimize the tension detecting error, at the same time, keep the machining error to a minimum. The recommended imbalance of tension detecting roller is class G1 of ISO 1940-1 (1986).

(2) When supporting the tension detecting roller at both ends, adjust the height of detector mounting surface. (\* The asterisked portion should be minimum in order to reduce the tension detecting error.)

When using spacer for adjusting the height, use the spacer in a shape capable of covering the entire mounting surface.

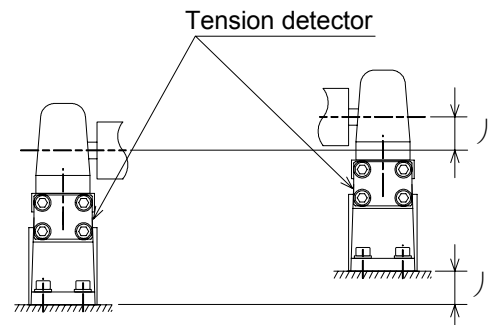

(3) The resultant force of tension due to material angle should be settled within the recommended resultant force range in the drawing with respect to the hinge position in order to keep the precision of tension detection.

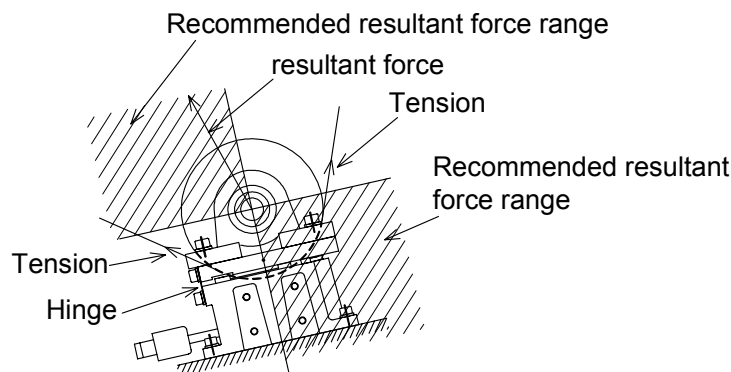

(4) If the detector bolt is loosened by mistake, the original characteristic is not restored if tightened again.

(5) When mounting the detector, be careful not to apply large impact load or excessive load, or admit cutting chips, screws or other foreign matter.

In particular, pay attention to the following points to avoid impact or excessive load when mounting.

- 1) If fixed without using self-aligned bearing, abnormal load is applied in the event of eccentricity or defective parallelism.
- 2) When the pillow block or roller is directly hit by hammer in order to adjust the parallelism between rollers.
- 3) When there is any person or object on the detecting roller.
- 4) When machine is transported after mounting the detecting roller, and vibration or impact is applied during transportation.
- 5) When the tension detector is dropped or transported without cushioning material.

(6) If using in environments accompanied by large temperature changes, employ a mechanism for absorbing length changes due to temperature changes of the tension detecting roller so as not to affect the tension detecting precision.

(7) In the case of low tension operation, minimize the mechanical loss to keep the tension control error to a minimum.

(8) The tension detecting roller cannot be supported at one side.

(9) Install guide rollers before and after the tension detector so that material angles  $\theta_1$ ,  $\theta_2$  may not differ.

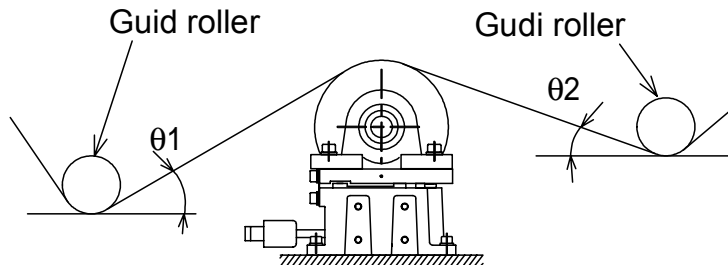

(10) When installing the roller, match the roller center and the center mark ( see outside dimensions ) of the tension detector.

### 3.2 Mounting

Use bolts with strenght of 10.9 or more specified in ISO 898-1 ( 1988 ).

(1) Detail of mounting of tension detector ( standard installing of LX-TD type ).

The pillow block fitting bolts should not be longer than the thickness "t" of the installing base of the detector side.

The pillow block, hexagon socket head bolts and others are to be prepared by the user.

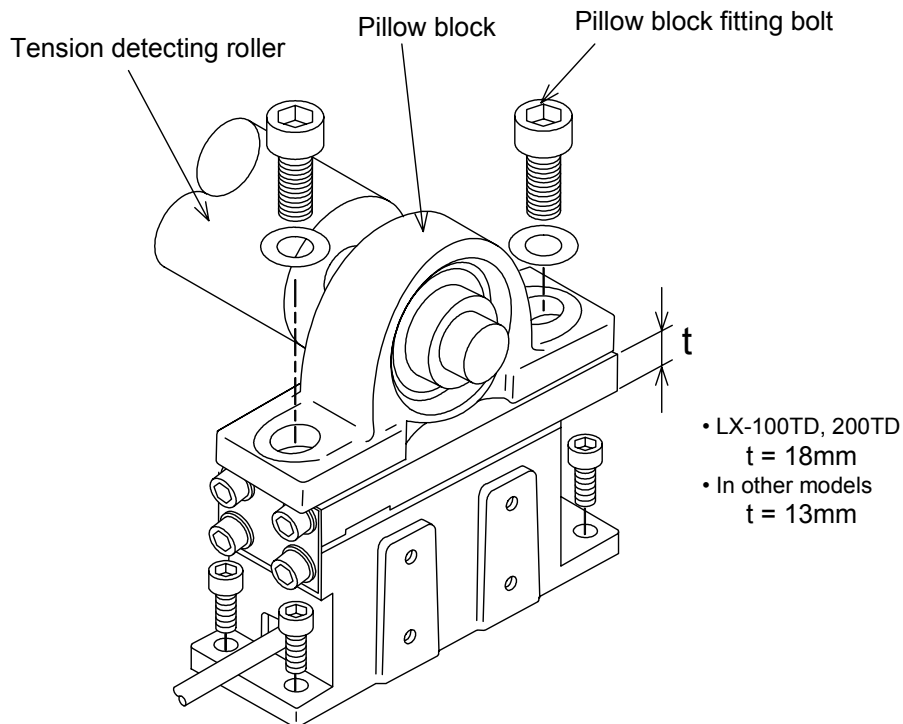

(2) Detail of mounting of tension detector ( when using LX-\*\*\*PLT of LX-TD type option ).  
 When the optional LX-\*\*\*PLT is purchased, LX-\*\*\*PLT fitting bolts are furnished.  
 However, the pillow block, hexagon socket head bolts and others are to be prepared by user.

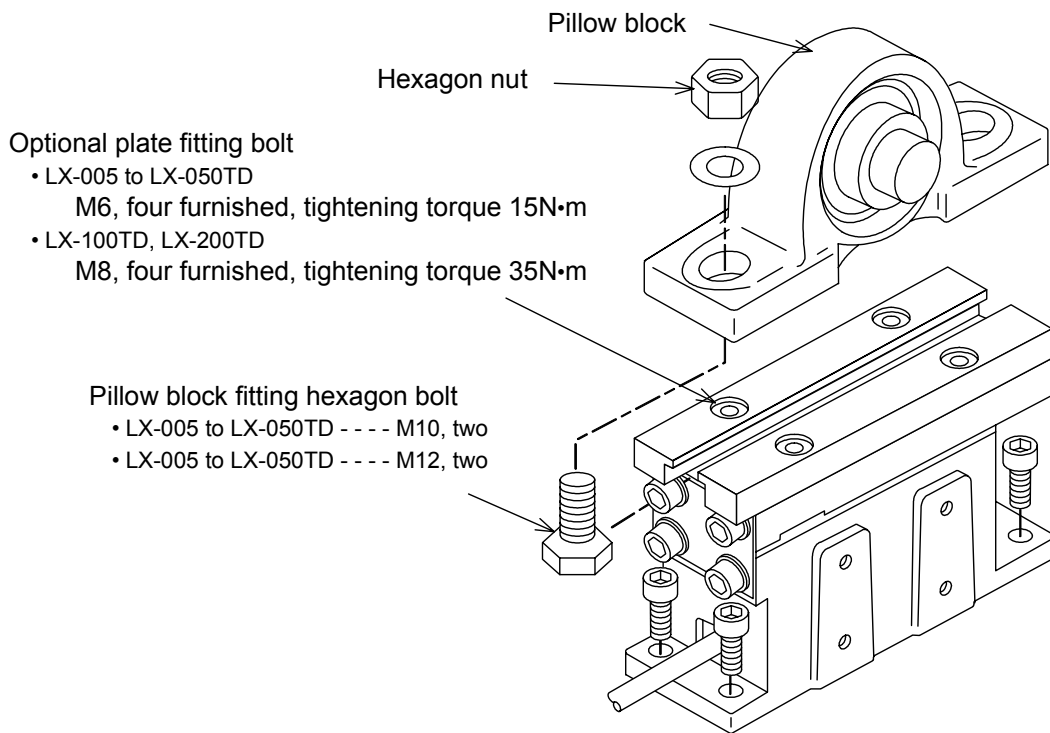

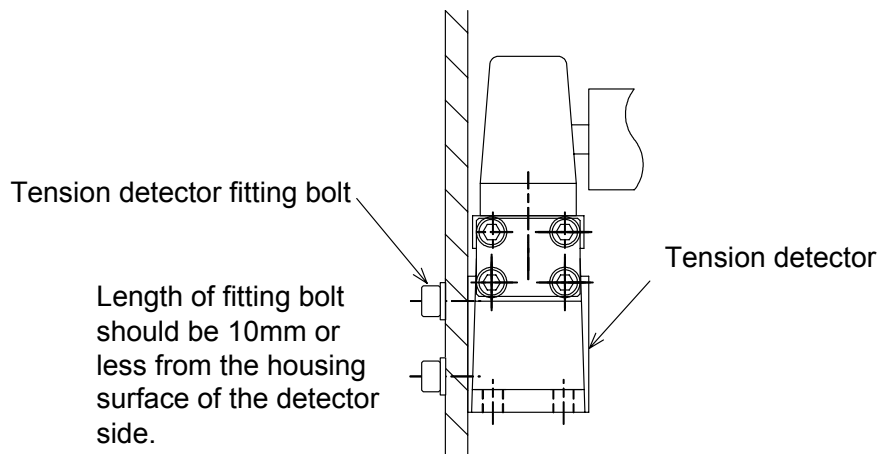

(3) Detail of mounting of tension detector ( example of LX-TD type wall mount ).





## 4. Wiring procedure

### 4.1 Caution for wiring

 DANGER	Do not drop sawdust or wire chips into product.
	Or it may lead to product damage, smoking, firing, or other danger.

### 4.2 Connection between tension detector and controller.

(1) The drawing shows the connection in the case of tension vector direction applied in the compressive direction.

When applied in the tensile direction, exchange the wiring of white and green.

(2) When extending the lead wire, use shielded wire.

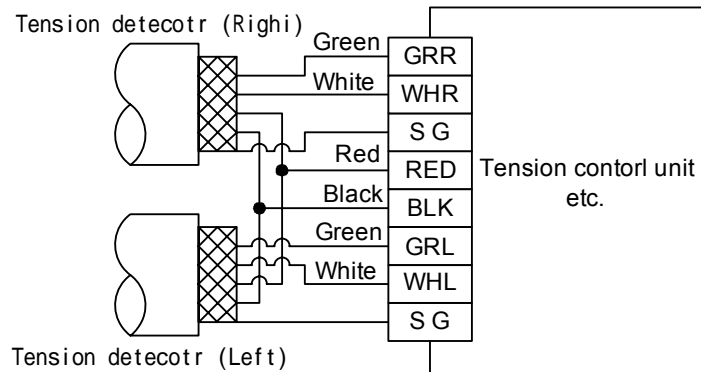

## 5. Operation

### 5.1 Caution for operation

 DANGER	Do not touch the product during operation.
During rotation of the detedting roller or other parts, don't touch the tension detector by hand, finger, or other parts of the body, or you may have electric shock or injury. Protect the exposed rotating and moving parts with cover to prevent from touching by hand or finger.	

During operation of the detector, be careful not to apply large impact load or excessive load. Impact or excessive load may be caused in the following cases.

- 1) When the dynamic balance of roller is poor and abnormal vibration is caused due to resonance or the like.
- 2) When accelerating or decelerating suddenly in the machine of large bobbin inertia.
- 3) When a winding shaft torque corresponding to maximum winding diameter is given by mistake in the case of small winding diameter.
- 4) When the material has an uneven tension.

## 6. Specifications

Type name	Standard type	LX-005TD	LX-015TD	LX-030TD	LX-050TD	LX-100TD	LX-200TD
	Explosion-proof type	LX-005TD-909	LX-015TD-909	LX-030TD-909	LX-050TD-909	LX-100TD-909	LX-200TD-909
Rated load ( N )		50	150	300	500	1000	2000
Applicable load direction		• Compression and tension directions.					
Mounting		• Floor mount, wall mount, ceiling mount					
Cable specification		• Standard type = 7m, $\phi 7$ ( furnished ), Explosion-proof type = 20m, $\phi 8$ ( furnished )					
Main body weight ( Kg )		• 1.8kg				• 3kg	
Conditions of use		• -5 to 40°C, vibration 2m/s <sup>2</sup> or less.					
Outside dimension		• Figure 1				• Figure 2	
Applicable bearing		• UCP-201 to 204 UCP205 is also usable by using optional LX-030PLT.				• UCP-201 to 204 UCP205 is also usable by using optional LX-100PLT.	

# 7. Outside dimensions

7.1 Figure 1----- LX-005TD, LX-015TD, LX-030TD, LX-050TD  
 LX-005TD-909, LX-015TD-909, LX-030TD-909, LX-050TD-909

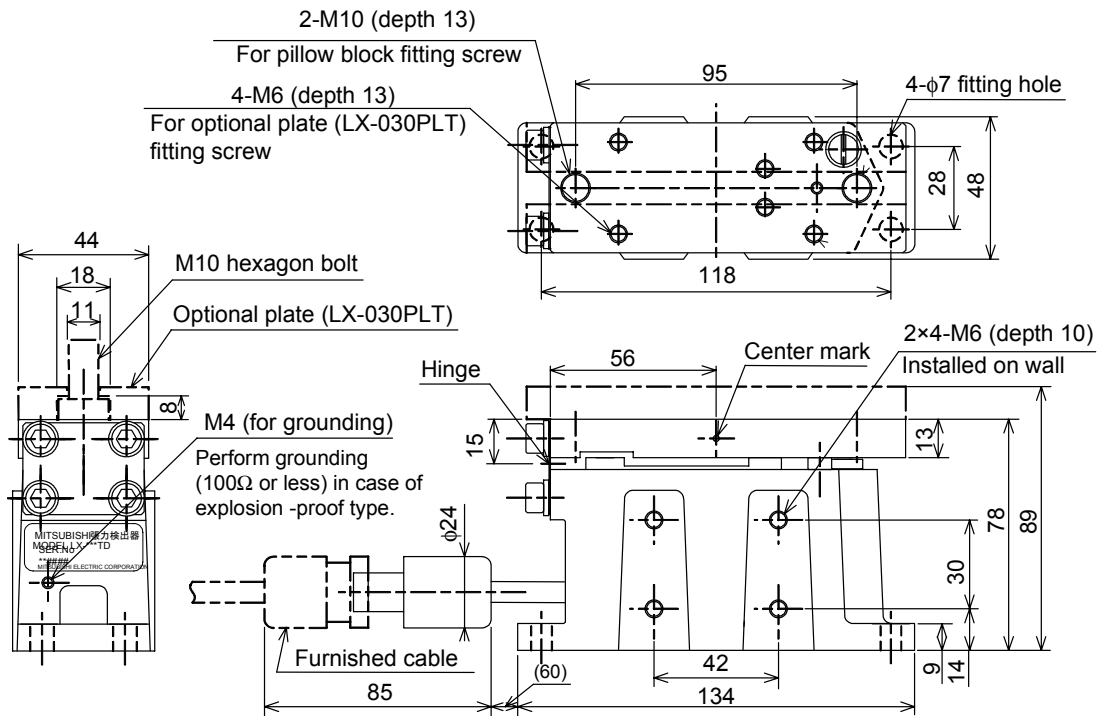

7.2 Figure 2----- LX-100TD, LX-200TD, LX-100TD-909, LX-200TD-909

