

Changes for the Better

MITSUBISHI

미쓰비시 **범용** AC 서보









미쓰비시전기주식회사 나고야제작소는 환경매니지먼트시스템 ISO14001 및 품질시스템 ISO 9001의 인증 취득 공장입니다.









MELSERVO-J2-Super 시리즈 더욱 다양화!

1.

			DIO	SSC NET	RS- 422	CC- Link					S/W		(kW) (1)	011K-CI	011M-CI	0110-CI	0111-CI	0112-CI	0113-CI	0114-CI				
MR J2S	MR-J2S- A 												0.05 ~37									(4)		
											(3)		0.05 ~0.4										(4)	
													0.5~55											
	SSCNET MR-J2S- B 												0.05 ~37										(4)	
											(3)		0.05 ~0.4											(4)
													0.5~55											
	MR-J2S- CP 		(5)	(9)									0.05 ~7											
							(8)						0.05 ~0.4											
	MR-J2S- CL 		(5)	(9)									0.05 ~7											
													0.05 ~0.4											
	MR J2M	MR-J2M-A (6) 											0.05 ~0.75											
		SSCNET MR-J2M-B (6) 					(7)						0.05 ~0.75											

1. (MRZJW3-MOTSZ111)
 2. (SV0308-1)_a
 3. LM
 4. AC
 5. (MR-HDP01)
 6. MR-J2M
 7. IO (MR-J2M-D01)
 8. MR-J2S-CP-S084
 9. (MR-J2M-P8A)
 (MR-J2M-DU)
 (MR-J2M-BU)
 (MR-J2M-P8B)
 (MR-J2M-DU)
 (MR-J2M-BU)
 #MELSERVO-J2M
 a

		(r/min)	(kW)				EN	UL cUL	(3)		
				(B)	(G1)	(G2, G5, G7)					
K 	HC-KFS	3000 (4500)	5 0.05, 0.1, 0.2, 0.4, 0.75					IP55 (IP65(4))	(6000r/min, 10000r/min)	<ul style="list-style-type: none"> • • • X-Y • • 	
		6000 (6000)	1 0.4	-	-	-		IP55			
		10000 (10000)	1 0.4	-	-	-					
M 	HC-MFS	3000 (4500)	5 0.05, 0.1, 0.2, 0.4, 0.75					IP55 (IP65(4))		<ul style="list-style-type: none"> • • 	
S 	HC-SFS	1000 (1500:0.85kW 1200:1.2~3kW)	4 0.85, 1.2, 2.0, 3.0		-	-		IP65	3	<ul style="list-style-type: none"> • • • X-Y 	
		2000 (3000:0.5~1.5kW 2500:2, 3.5kW 2000:5.7kW)	14 0.5, 1.0, 1.5, 2.0, 3.5, 5.0, 7.0, 0.5, 1.0, 1.5, 2.0, 3.5, 5.0, 7.0					IP65			
		3000 (3000)	5 0.5, 1.0, 1.5, 2.0, 3.5		-	-		IP65			
L 	HC-LFS	2000 (3000)	5 0.5, 1.0, 1.5, 2.0, 3.0		-	-		IP65		<ul style="list-style-type: none"> • • • 	
R 	HC-RFS	3000 (4500)	5 1.0, 1.5, 2.0, 3.5 5.0		-			IP65		<ul style="list-style-type: none"> • 	
L 	HA-LFS	1000 (1200)	16 6.0, 8.0, 12, 15, 20 25, 30, 37, 6.0, 8.0, 12, 15, 20, 25(6), 30, 37	(6.0~ 12kW)	-	-		IP44	3 30kW 가 (7)	<ul style="list-style-type: none"> • • • 	
		1500 (2000)	14 7.0(11, 15, 22, 30, 37 7.0(11, 15, 22, 30, 37, 45, 50	(7.0~ 15kW)	-	-		IP44			
		2000 (2000)	14 5.0, 7.0, 11, 15, 22, 30, 37, 11, 15, 22, 30, 37, 45, 55	(11~ 22kW)	-	-		IP44 HA-LFS502 /702 IP65			
U 	HC-UFS	2000 (3000:0.75~2kW 2500:3.5, 5kW)	5 0.75, 1.5, 2.0, 3.5 5.0		-	-		IP65		<ul style="list-style-type: none"> • • 	
		3000 (4500)	4 0.1, 0.2, 0.4, 0.75		-	-		IP65 (5)			

1. ()
2. ()
3. ()
4. 50W
5. IP65 (HC-UFS -S1)
6. 400V .HA-LFS 1000r/min 400V 6.0~12kW 20, 25kW
7. 15~25kW 가

2. ,

131072p/rev(17bit)

•

CPU

- CPU 550Hz 가

가

- 가

SSCNET() : B

- SSCNET 0.888ms

- 가

•

•

- SSCNET 가

•

- 가 100

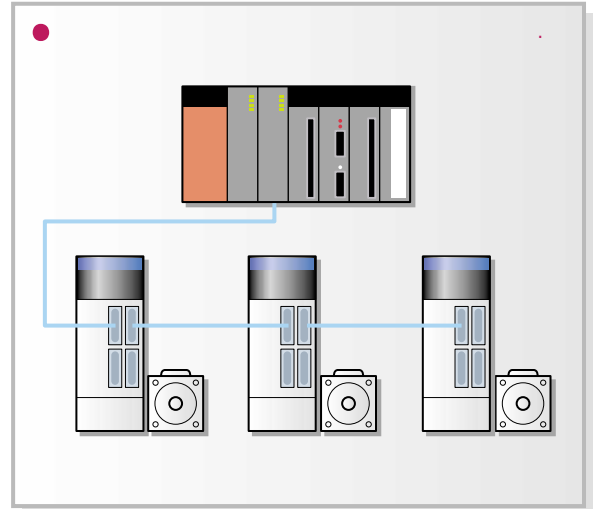

Global standard



3.

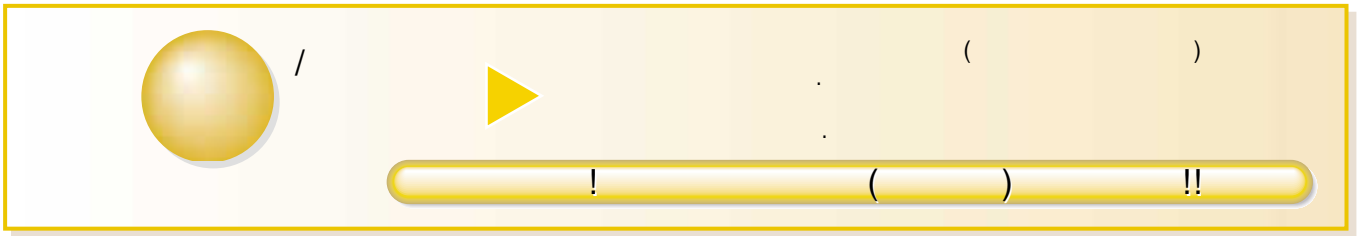

MR Configurator()

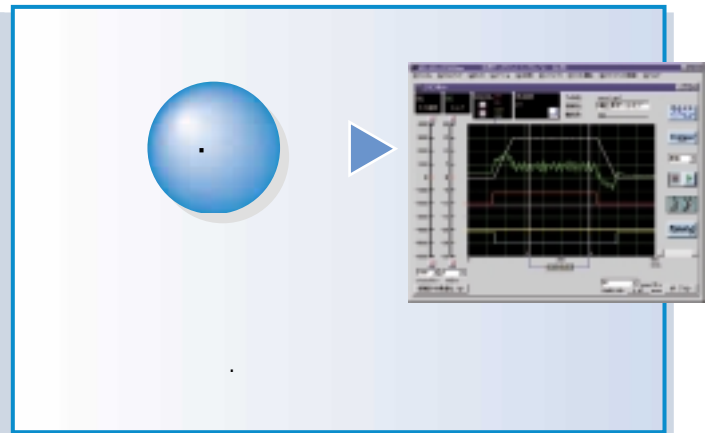
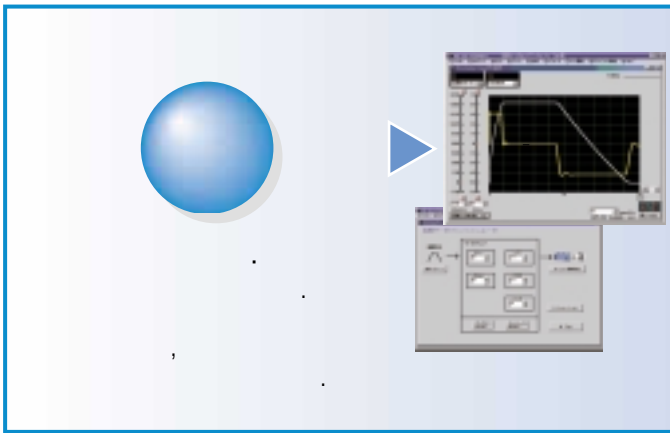
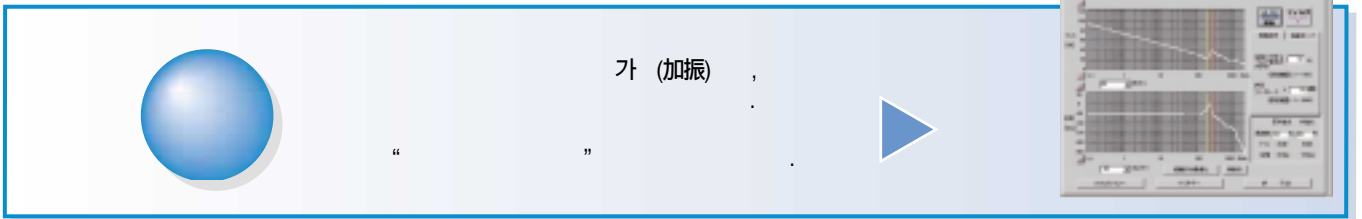

Contents

	A	B	CP	CL
	P.1	P.1	P.1	P.1
	P.5	P.5	P.5	P.5
	P.7	P.10	P.13	P.19
100V · 200V	P.8	P.11	P.15	P.23
400V	P.9	P.12	-	-
/	-	-	P.16	P.21
	P.24	P.27	P.28	P.30
/	P.31	P.31	P.31	P.31
CN2	P.33	P.33	P.33	P.33
CN3/CN4/CON2	P.35	P.35	P.35	P.35
HC - KFS	P.36	P.36	P.36	P.36
HC - MFS	P.37	P.37	P.37	P.37
HC - LFS	P.38	P.38	P.38	P.38
HC - SFS	P.39	P.39	P.39	P.39
HC - RFS	P.42	P.42	P.42	P.42
HA - LFS (1)	P.43	P.43	P.43	P.43
HC - UFS	P.49	P.49	P.49	P.49
	P.50	P.50	P.50	P.50
	P.52	P.52	P.52	P.52
	P.53	P.53	P.53	P.53
100V · 200V	P.55	P.59	P.55	P.55
400V	P.55	P.59	-	-
	P.63	P.63	P.63	P.63
	P.64	P.64	-	-
	P.64	-	P.64	P.64
	P.65	P.65	P.65	P.65
	P.69	P.69	P.69	P.69
	P.69	P.69	P.69	P.69
	-	-	P.69	P.69
	-	-	P.69	P.69
	P.70	P.70	-	-

	A	B	CP	CL
MR Configurator	P.75	P.75	P.75	P.75
()	P.70	P.70	P.70	P.70
	P.70	P.70	P.70	P.70
	P.71	P.71	P.71	P.71
	P.72	P.72	P.72	P.72
	P.72	P.72	P.72	P.72
	P.72	P.72	P.72	P.72
	P.72	P.72	P.72	P.72
	P.72	P.72	P.72	P.72
EMC	P.73	P.73	P.73	P.73
() (3)	P.76	P.76	P.76	P.76
100V · 200V	P.77	P.77	P.77	P.77
400V	P.78	P.78	-	-
(30kW)	P.80	P.80	-	-
HC - KFS	P.81	P.81	P.81	P.81
HC - MFS	P.81	P.81	P.81	P.81
HC - SFS	P.89	P.89	P.89	P.89
HC - LFS	P.95	P.95	P.95	P.95
HC - RFS	P.96	P.96	P.96	P.96
HA - LFS (1)	P.100	P.100	P.100	P.100
HC - UFS	P.104	P.104	P.104	P.104
	P.106	P.106	P.106	P.106
(MR - J2)	P.122	P.122	P.122	P.122
	P.123	P.123	P.123	P.123
FA	P.126	P.126	P.126	P.126

1. MR - J2S - CP MR - J2S - CL 7kW
 2.
 3. (MRJW3 - MOTSZ111)

100V/200V

MR - J2S - 10 A 1 - □

미쓰비시 범용 AC 서보앰프
MELSERVO-J2-Super 시리즈

특수 대응

A : 범용 인터페이스
B : SSCNET 대응
CP : 위치결정 기능 내장 (주)
CL : 프로그램운전 기능 내장 (주)

주) MR-J2S-CP 타입 및 CL 타입은 0.05~7kW로 대응하고 있습니다.

	AC200V	AC230V (1)
1	AC100V (2)	

) 1. AC230V MR-J2S-70
2. MR-J2S-40

EN, UL, cUL

	HC-KFS	HC-MFS	HC-SFS	HC-LFS	HC-RFS	HA-LFS	HC-UFS
10	053, 13	053, 13	-	-	-	-	13
20	23	23	-	-	-	-	23
40	43	43	-	-	-	-	43
60	-	-	52, 53	52	-	-	-
70	73, 46, 410	73	-	-	-	-	72, 73
100	-	-	81, 102, 103	102	-	-	-
200	-	-	121, 201, 152, 202, 153, 203	152	103, 153	-	152
350	-	-	301, 352, 353	202	203	-	202
500	-	-	502	302	353, 503	502	352, 502
700	-	-	702	-	-	601, 701M, 702	-
11K	-	-	-	-	-	801, 12K1, 11K1M, 11K2	-
15K	-	-	-	-	-	15K1, 15K1M, 15K2	-
22K	-	-	-	-	-	20K1, 25K1, 22K1M, 22K2	-
30K	-	-	-	-	-	30K1, 30K1M, 30K2	-
37K	-	-	-	-	-	37K1, 37K1M, 37K2	-

30kW

(MR-HP30KA)

400V

MR - J2S - 30K A 4 - □

미쓰비시 범용 AC 서보앰프
MELSERVO-J2-Super 시리즈

특수 대응

A : 범용 인터페이스
B : SSCNET 대응

삼상 AC400V

EN, UL, cUL

	HC-SFS	HA-LFS
60	524	-
100	1024	-
200	1524, 2024	-
350	3524	-
500	5024	-
700	7024	6014, 701M4
11K	-	8014, 12K14, 11K1M4, 11K24
15K	-	15K14, 15K1M4, 15K24
22K	-	20K14, 22K1M4, 22K24
30K	-	25K14, 30K14, 30K1M4, 30K24
37K	-	37K14, 37K1M4, 37K24
45K	-	45K1M4, 45K24
55K	-	50K1M4, 55K24

30kW

(MR-HP55KA4)

200V HC-MFS

05

3

B

HC-KFS	
HC-MFS	
HC-SFS	
HC-LFS	
HC-RFS	
HA-LFS	
HC-UFS	

EN, UL, cUL

	(kW)
05	0.05
1-8	0.1~0.85
10-80	1.0~8.0
11K-37K	11.0~37.0

	(r/min)
1	1000
1M	1500
2	2000
3	3000
6	6000
10	10000

G1	()
G1H	() (1)
G2	
G5	
G7	

) 1. HC-SFS2000r/min
2. r

B	
---	--

K	()
D	D ()

400V HA-LFS

30K

2

4

B

HC-SFS	
HA-LFS	

400V클래스

	(kW)
5	0.5
10-80	1.0~8.0
11K-55K	11.0~55.0

	(r/min)
1	1000
1M	1500
2	2000

G1	() (1)
G1H	() (1)
G2	(1)
G5	(1)
G7	(1)

) HA-LFS 1000r/min 6.0~12kW, 20kW, 25kW
HA-LFS 1500r/min 7.0kW

) 1. HC-SFS2000r/min
2. r

B	
---	--

K	()
---	-----

EN, UL, cUL

MR-J2S-A

MR-J2S-A

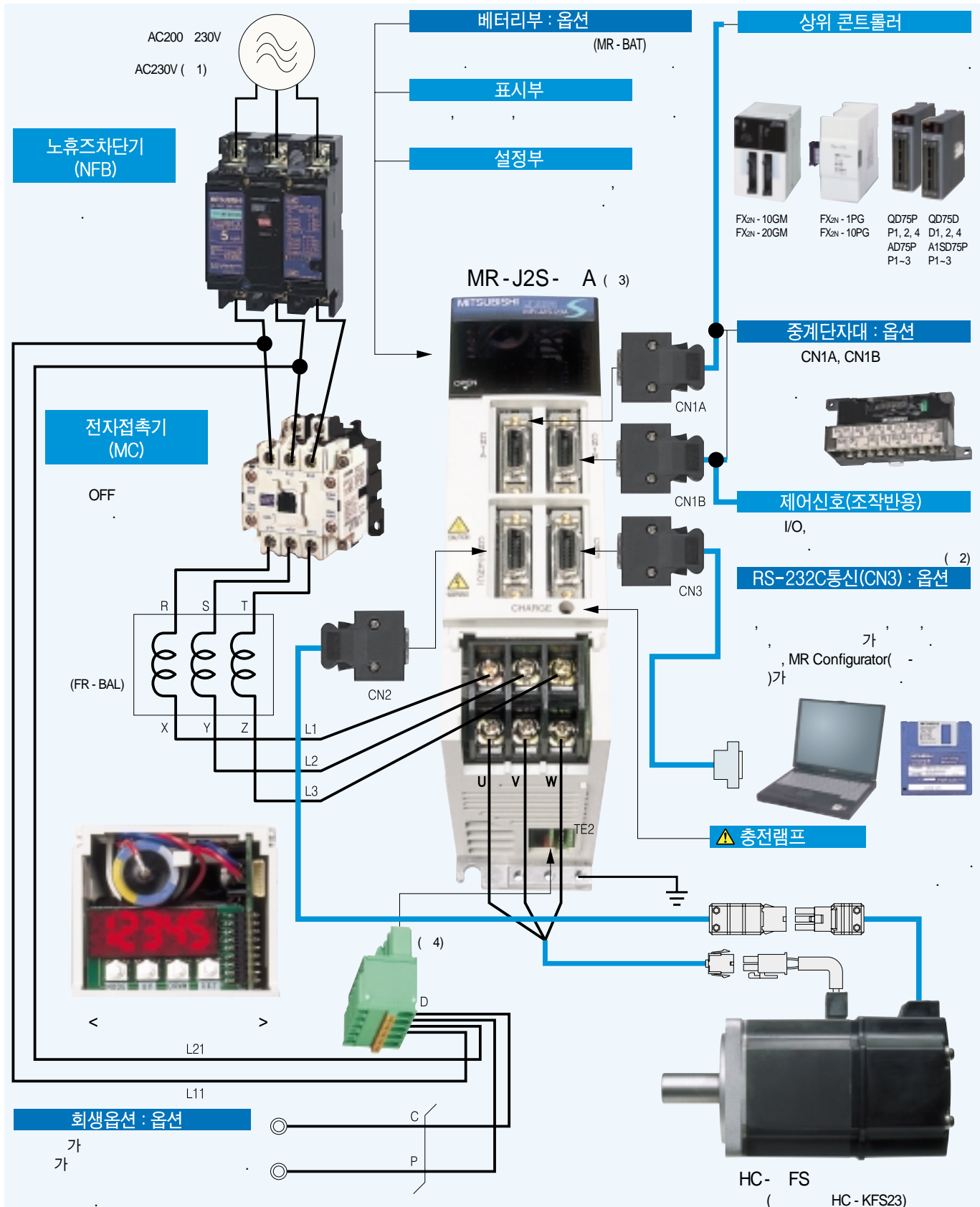

1. AC230V L1·L2 L3
 2. RS-232C RS-422 RS-422 가
 3. CN1 (MR-J2CN1) MR-J2S-500A MR-J2S-600A(400V)
 4. MR-J2S-100A (MR-J2S-A-RT) 가

MR-J2S-A()

100V/200V

MR-J2S-		10A	20A	40A	60A	70A (-U)	100A	200A	350A	500A	700A	11KA	15KA	22KA	30KA	37KA	10A1	20A1	40A1			
																	MR-HP30KA					
		AC200~230V/50, 60Hz															AC100~120V/50, 60Hz					
		AC170~253V															AC85~127V					
		±5%															±5%					
(W)		50															50					
(1)		AC200~230V/50, 60Hz AC230V/50, 60Hz(2)					AC200~230V/50, 60Hz(2)										AC100~120V/50, 60Hz(2)					
		AC200~230V : AC170~253V AC230V : AC207~253V					AC170~253V										AC85~127V					
		±5%															±5%					
		PWM																				
		(3)															(3)					
		500kpps(), 200kpps()																				
		1 : 131072p/rev																				
		A/B A=1-65535 131072, B=1-65535 1/50<A/B<500																				
		0~±10000pulse()																				
		±2.5																				
		(DC 0~+10V/)																				
		1 : 2000, 1 : 5000																				
		DC 0~±10V / (4)																				
		±0.01% (0~100%)																				
		0%(±10%)																				
		±0.2% (25 ±10)																				
		(DC 0~+10V/)																				
		DC 0~±8V/ (10~12kΩ)																				
		(DC 0~±10V/)																				
		(IP00)					(IP00)										(IP00)					
		0~55 (), : -20~65 ()																				
		90%RH (가), : 90%RH (가)																				
		(), 가 . 가 . 가																				
/		1000m / 5.9m/s ²																				
(kg)		0.7	0.7	1.1	1.1	1.7	1.7	2.0	2.0	4.9	7.2	15	16	20	47	47	0.7	0.7	1.1			
()																	AC200~230V/50, 60Hz (2)					
																	AC170~253V/50, 60Hz					
																	±5%					
																	AC200~230V/50, 60Hz					
																	AC170~253V/50, 60Hz					
																	±5%					
(W)																	50					
(kg)																	22					

1. 2. 3. 4. 10V (MR-J2S-A-ED MR-J2S-A1-ED) 가 No.25 가

MR-J2S-	10A~70A	100A~350A	500A, 700A	11KA~22KA	30KA, 37KA	10A1~40A1
P.24~26						
/	P.31	P.31	P.31	P.32	P.32	P.31
CN2	P.33	P.33, P.34		P.34		P.33
CN3/CN4/CON2	P.35			P.35		P.35

MR-J2S-A()

400V

MR-J2S-		60A4	100A4	200A4	350A4	500A4	700A4 (-U)	11KA4 (-U)	15KA4 (-U)	22KA4 (-U)	30KA4 (-U)	37KA4	45KA4	55KA4	
												MR-HP55KA4			
		DC24V					AC380~480V/50, 60Hz								
		DC20.4~27.6V					AC323~528V								
	(W)	-					±5%								
		25					50								
	(1)	AC380~480V/50, 60Hz(2)													
		AC323~528V													
		±5%													
		PWM													
		(),													
		500kpps(), 200kpps()													
		1 : 131072p/rev													
		A/B A=1~65535 131072, B=1~65535 1/50<A/B<500													
		0~±10000pulse()													
		±2.5													
		1 : 2000, 1 : 5000													
		DC 0~±10V / (3)													
		±0.01% (0~100%)													
		0%(±10%)													
		±0.2% (25 ±10)													
		(DC 0~+10V/)													
		DC 0~±8V/ (10~12kΩ)													
		(DC 0~±10V/)													
		(IP00)													(IP00)
		0~55 (), : -20~65 ()													
		90%RH (가), : 90%RH (가)													
		(), 가 . 가 . 가													
		1000m / 5.9m/s ²													
		(kg)	2.1	2.2	2.2	5	5	7.2	15	16	20	36	47	47	47
	(1)											AC380~480V/50, 60Hz (2)			
												AC323~528V/50, 60Hz			
		±5%													
												AC380~480V/50, 60Hz			
												AC323~528V/50, 60Hz			
		±5%													
		(W)													50
		(kg)													22

1.
2.
3. 10V No.25 가

MR-J2S-		60A4~200A4		350A4, 500A4		700A4	11KA4~22KA4		30KA4~55KA4						
												P.24~26			
		P.32		P.32		P.32		P.32							
CN2		P.33				P.33 P.34		P.34							
CN3/CN4/CON2		P.35						P.35							

MR-J2S-B

MR-J2S-B

MR-J2S-B SSCNET

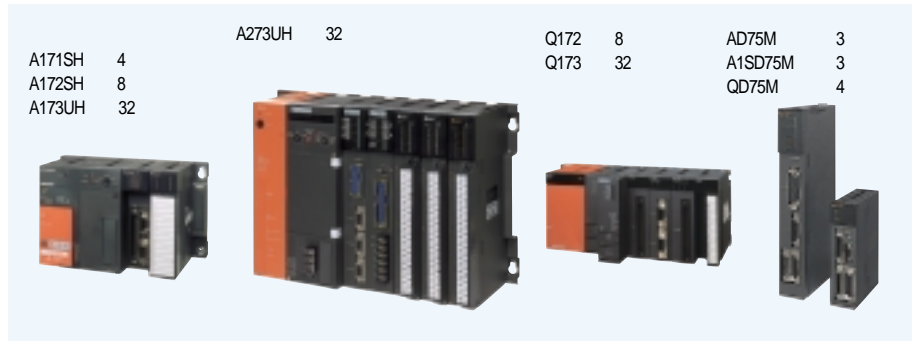

SSCNET

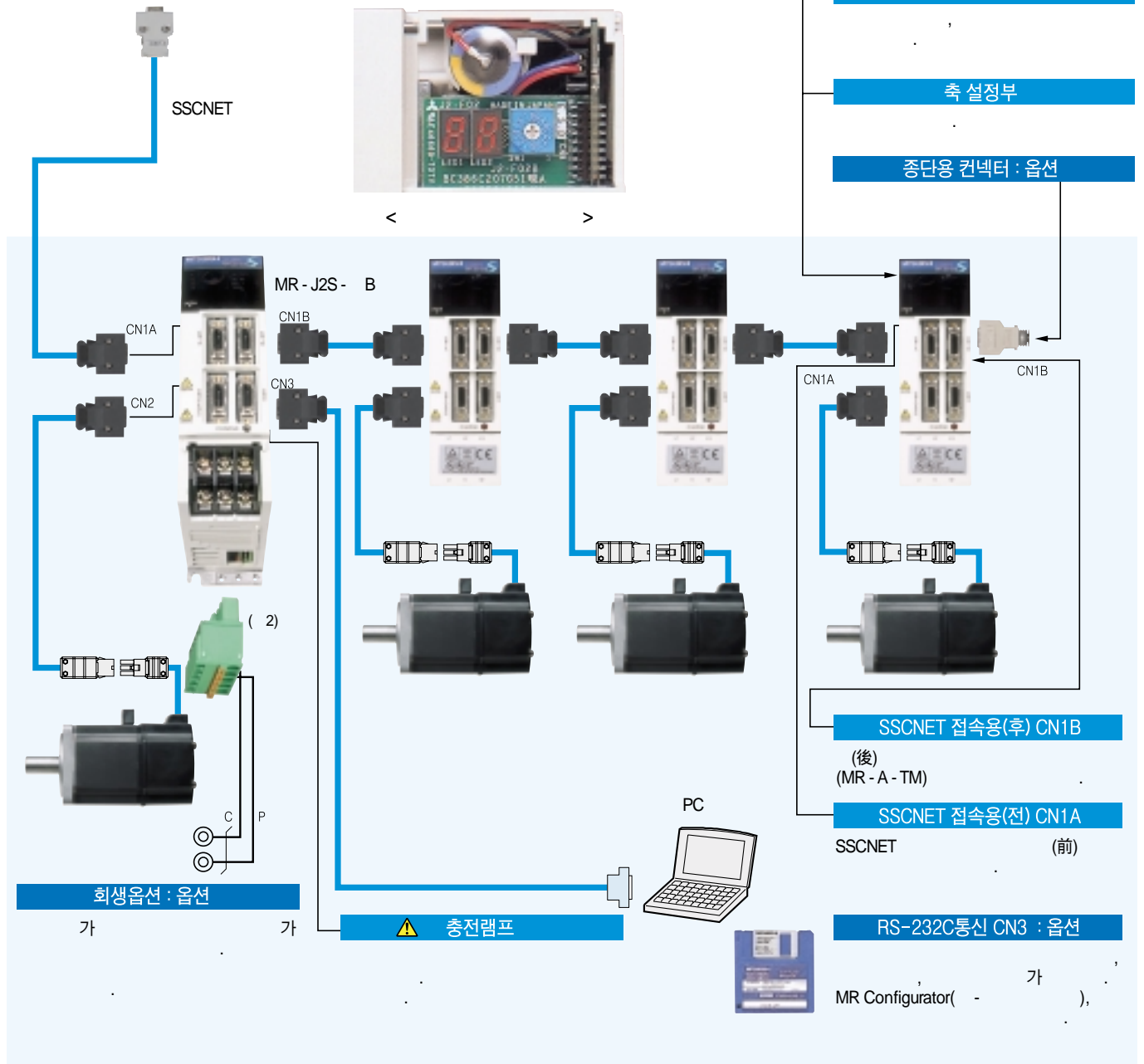

1) MR-J2S-350B
MR-J2S-500B
2) MR-J2S-100B

P.7
MR-J2S-60B4(400V)
(MR-J2S-B-RT)

MELSERVO J2 Super

MR-J2S-B(SSCNET)

100V/200V

MR-J2S-		10B	20B	40B	60B	70B (-U)	100B	200B	350B	500B	700B	11KB	15KB	22KB	30KB	37KB	10B1	20B1	40B1	
																MR-HP30KA				
		AC200~230V/50, 60Hz														AC100~120V/50, 60Hz				
		AC170~253V														AC85~127V				
		±5%														±5%				
	(W)	50														50				
	(1)	AC200~230V/50, 60Hz					AC200~230V/50, 60Hz(2)										AC100~120V/50, 60Hz(2)			
		AC200~230V					AC170~253V					AC170~253V				AC85~127V				
		AC230V					AC207~253V					AC170~253V				AC85~127V				
		±5%														±5%				
		PWM																		
		(3)														(3)				
		()														()				
		10Mpps																		
		(IP00)														(IP00)				
		0~55 ()														-20~65 ()				
		90%RH (가)														90%RH (가)				
		()														가 . 가 . 가				
		1000m																		
		5.9m/s ²																		
	(kg)	0.7	0.7	1.1	1.1	1.7	1.7	2.0	2.0	4.9	7.2	15	16	20	47	47	0.7	0.7	1.1	
	(1)															AC200~230V/50, 60Hz(2)				
																AC170~253V/50, 60Hz				
																±5%				
																AC200~230V/50, 60Hz				
																AC170~253V/50, 60Hz				
	(W)															±5%				
	(kg)															50				
																22				

- 1.
- 2.
- 3.

(MR-J2S- B-ED MR-J2S- B1-ED) 가

MR-J2S-		10B~70B			100B~350B			500B,700B			11KB~22KB			30KB, 37KB		10B1~40B1		
		P.27																
/		P.31			P.31			P.31			P.32			P.32		P.31		
CN2		P.33			P.33			P.34			P.34			P.34		P.33		
CN3/CN4/CON2		P.35																

400V

MR-J2S-		60B4	100B4	200B4	350B4	500B4	700B4 (-U)	11KB4 (-U)	15KB4 (-U)	22KB4 (-U)	30KB4 (-U)	37KB4	45KB4	55KB4	
		-										MR-HP55KA			
		DC24V					AC380~480V/50, 60Hz								
		DC20.4~27.6V					AC323~528V								
		-					±5%								
		(W) 25					50								
	(1)	AC380~480V/50, 60Hz(2)													
		AC323~528V													
		±5%													
	PWM														
10Mpps															
		(IP00)													(IP00)
	0~55 (), : -20~65 ()														
	90%RH (가), : 90%RH (가)														
	(), 가 . 가 . 가														
	1000m														
		5.9m/s ²													
(kg)		2.1	2.2	2.2	5	5	7.2	15	16	20	36	47	47	47	
(1)	-										AC380~480V/50, 60Hz(2)				
	-										AC323~528V/50, 60Hz				
	-										±5%				
	-										AC380~480V/50, 60Hz				
	-										AC323~528V/50, 60Hz				
	-										±5%				
(W)		-										50			
(kg)		-										22			

) 1.
2.

MR-J2S-	60B4~200B4	350B4, 500B4	700B4	11KB4~22KB4	30KB4~55KB4
	P.27				
/	P.32	P.32		P.32	P.32
CN2	P.33		P.33 P.34	P.34	
CN3/CN4/CON2	P.35			P.35	

MR-J2S-CP

- (), , 가 .
- DI/O .
- RS-422 (32) 가 .

MR-J2S-CP

<DI/O >

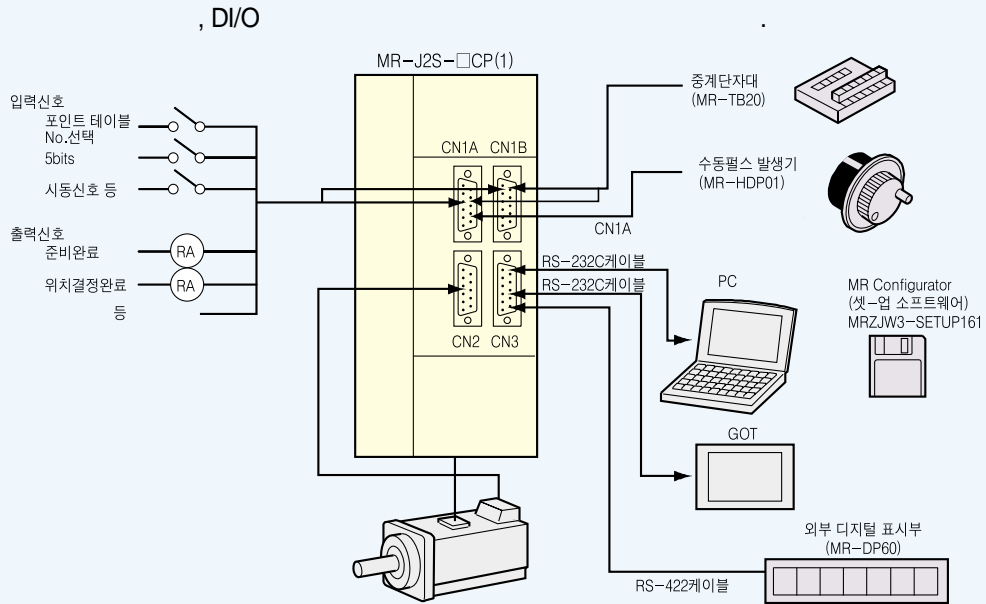

<RS-422 >

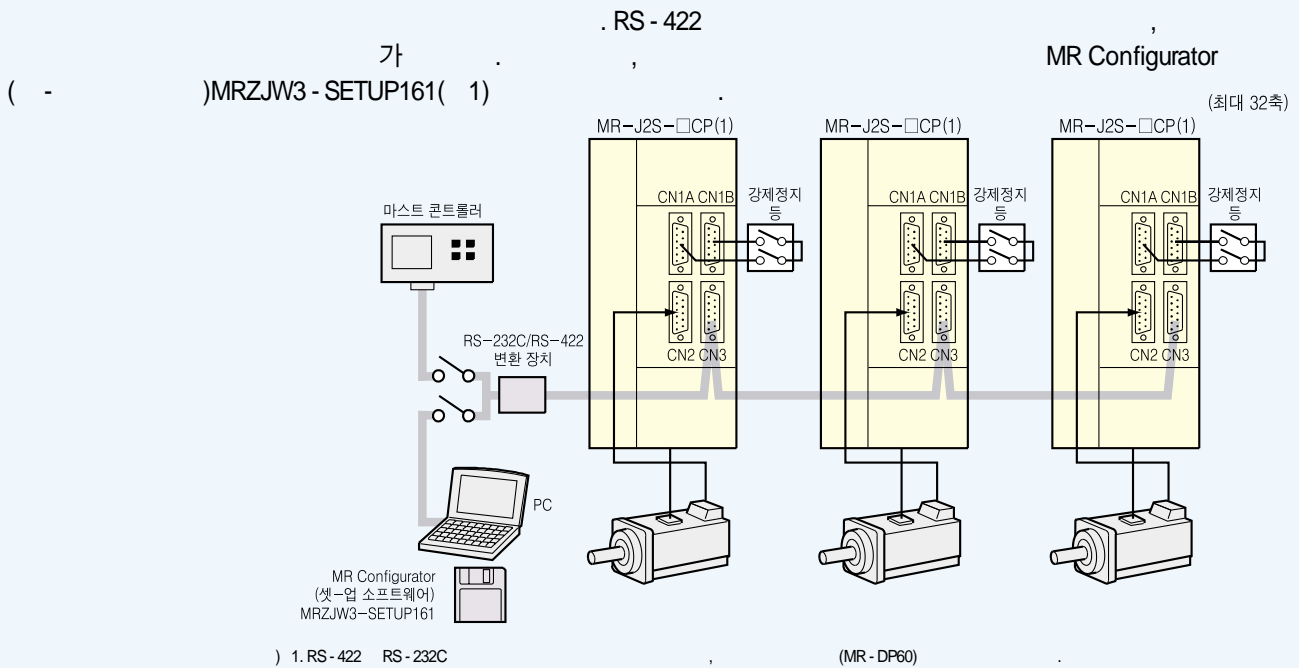

< RS-422(RS-232C) >

- 9600/19200/38400/57600 (bps)
- bit : 1bit bit : 8bit
- bit : 1bit bit : 1bit
- , 2

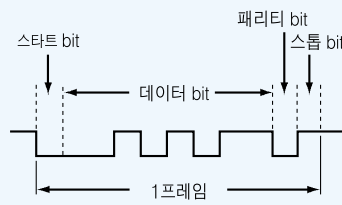

MR-J2S-CP

MR-J2S-CP

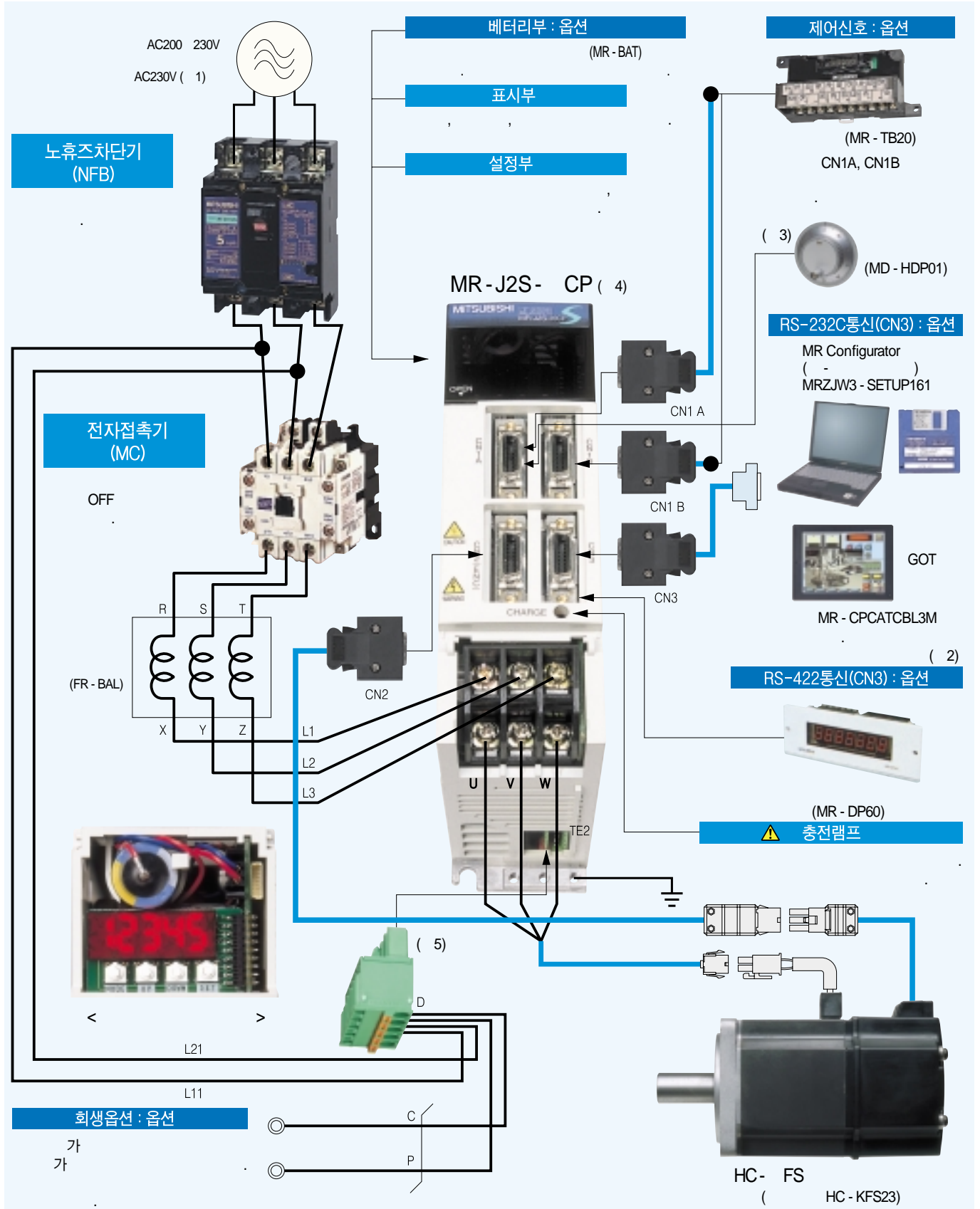

- 1. AC230V
 - 2. RS - 232 RS - 422
 - 3. RS - 422
 - 4. MR - J2S - 350CP
 - 5. MR - J2S - 100CP
- L1 · L2 L3 RS - 422 가
- CN1 (MR - J2CN1)
CN1 (MR - J2CN1)
- MR - J2S - 500CP
(MR - J2S - CP - RT)
- 가

MR-J2S-CP()

MR-J2S-		10CP	20CP	40CP	60CP	70CP (-U)	100CP	200CP	350CP	500CP	700CP	10CP1	20CP1	40CP1
(1)	AC200~230V/50, 60Hz AC230V/50, 60Hz(2)					AC200~230V/50, 60Hz(2)					AC100~120V/50, 60Hz(2)			
	AC200~230V : AC170~253V AC230V : AC207~253V					AC170~253V					AC85~127V			
±5%														
PWM														
(3)														
() ,														
No. (31)														
1 : ±1(μm)~±999.999(mm)														
가														
S 가 No.14														
RS-422 (RS-232C)														
RS-422 (RS-232C) .1 : ±1(μm)~±999.999(mm)														
가 RS-422 (RS-232C) RS-422 (RS-232C)														
S 가 No.14														
1														
(2~31) , (2~31)														
J O G RS-422 (RS-232C)														
: ×1, ×10, ×100														
Z 가 , 가 , 가														
가 , 가 , 가														
가 , 가														
가 , 가														
(ON) ON (SON) ON 가														
(後) 가 , 가 , 가														
(前) 가 , 가 , 가														
가 , Z 가 , 가 , 가														
(IP00)					(IP00)					(IP00)				
0~55 () , : -20~65 ()														
90%RH (가) , : 90%RH (가)														
() , 가 . 가 . 가														
1000m														
5.9m/s ²														
(kg)		0.7	0.7	1.1	1.1	1.7	1.7	2.0	2.0	4.9	7.2	0.7	0.7	1.1

- 1.
- 2.
3. (MR-J2S-CP-ED MR-J2S-CP1-ED) 가

MR-J2S-	10CP~70CP	100CP~350CP	500CP, 700CP	10CP1~40CP1
/	P.31	P.28	P.31	P.31
CN2	P.33	P.33 , P.34		P.33
CN3/CN4/CON2		P.35		

MR-J2S-CP ()

가 가

No.	No.	(31)
	.1	: ±1 (μm)~ ±999.999(mm)
	.가	.S 가 No.14
	RS-422 (RS-232C)	
	RS-422 (RS-232C)	.1 : ±1(μm)~ ±999.999(mm)
	RS-422 (RS-232C)	.가 RS-422(RS-232C)
	S 가	No.14

< > ...

가

(1)

	-999999~999999	$\times 10^{STM} \mu m$. STM
	0~	r/min	
가	0~20000	ms	가
	0~20000	ms	
	0~20000	ms	
	0~1	-	0: () 1: ()

●보조기능1

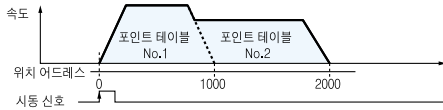

●보조기능0

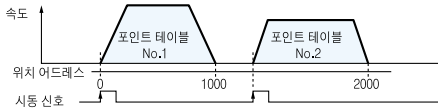

((1))

No.	가					
1	1000	2000	200	200	0	1
2	2000	1600	100	100	0	0
31	-1000	3000	100	100	0	0
	No.1	1				
1」	No.1	0				
0」	가					

(2)

	0~999999	$\times 10^{STM} \mu m$. STM
	0~	r/min	
가	0~20000	ms	가
	0~20000	ms	
	0~20000	ms	
	0~1	-	0: () 1: ()

((2))

No.	가					
1	1000	2000	200	200	0	1
2	1000	1600	100	100	0	0
31	500	3000	100	100	0	0
	No.1	1				
1」	No.1	0				
0」	가					

(3)

	-999999~999999	$\times 10^{STM} \mu m$. STM . STM
	0~	r/min	
가	0~20000	ms	가
	0~20000	ms	
	0~20000	ms	
	0~3	-	0: () 1: () 2: () 3: ()

((3))

No.	가					
1	1000	2000	200	200	0	1
2	1000	1600	100	100	0	2
31	3000	3000	100	100	0	2
	No.1	1	3			
1」	1	3」				
	No.1	0	2			
1」	0	2」				
	가					

●보조기능1 또는 3

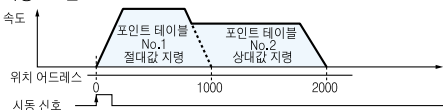

●보조기능0 또는 2

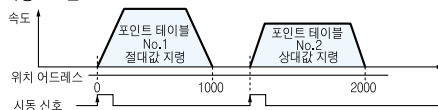

MELSERVO T2 Super MR-J2S-CP-S084 /

CC-Link

「MR-J2S- CP-S084」
가 .AC

「MR-J2S-T01」

MR-J2S-CP-S084

CC-Link



- 가
- , , CC-Link
-
- AC

MR-J2S-CP-S084

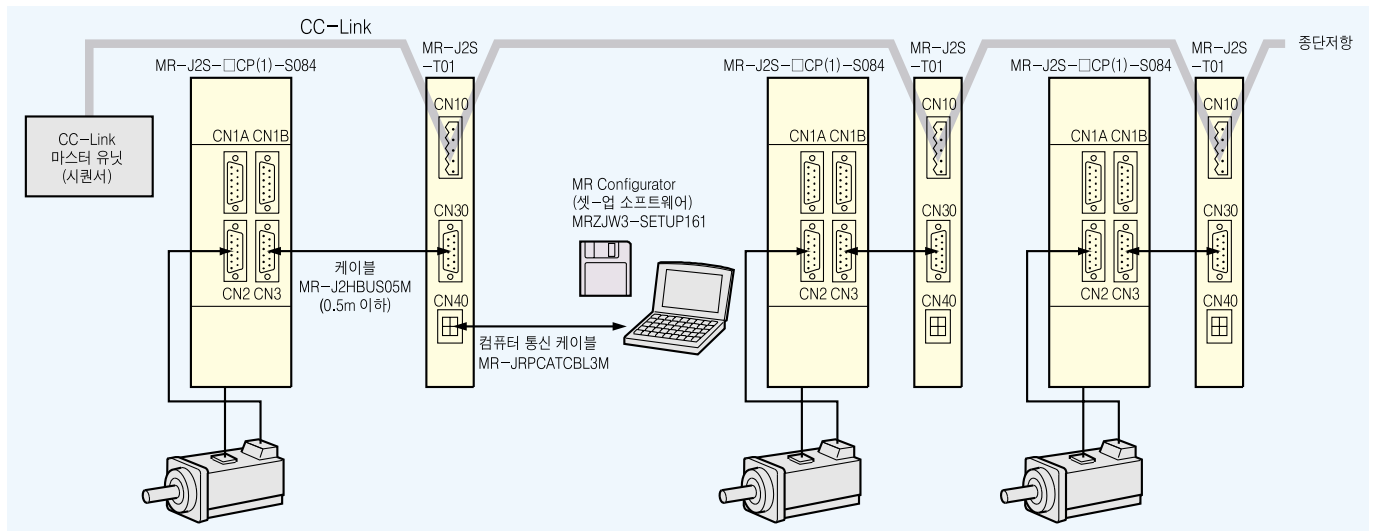

MR-J2S-CP-S084

MR-J2S-	10CP-S084	20CP-S084	40CP-S084	60CP-S084	70CP-S084 (U)	100CP-S084	200CP-S084	350CP-S084	500CP-S084	700CP-S084	10CP1-S084	20CP1-S084	40CP1-S084
(1)	AC200~230V/50, 60Hz AC230V/50, 60Hz(2)					AC200~230V/50, 60Hz (2)					AC100~120V/50, 60Hz(2)		
	AC200~230V : AC170~253V AC230V : AC207~253V					AC170~253V					AC85~127V		
	±5%												
	PWM												
	() , , , ,												
					(IP00)			(IP00)			(IP00)		
	0~55 () , : -20~65 ()					90%RH (가) , : 90%RH (가)							
	() , 가 . 가 . 가												
	1000m												
	5.9m/s ²												
(kg)	0.7	0.7	1.1	1.1	1.7	1.7	2.0	2.0	4.9	7.2	0.7	0.7	1.1

1.
2.

MR-J2S-	10CP-S084 ~ 70CP-S084	100CP-S084 ~ 350CP-S084	500CP-S084, 700CP-S084	10CP1-S084 ~ 40CP1-S084
	P.29			
/	P.31	P.31	P.31	P.31
CN2	P.33	P.33 , P.34		P.33
CN3/CN4/CON2	P.35			

CC-Link

CC-Link

MR-J2S-CP-S084

CC-Link		MR-J2S-T01				
		DC5V				
C C · L i n k	C C - L i n k	Ver.1.10				
		MR-J2S-CP(1)-S084				
		10M/5M/2.5M/625K/156Kbps				
		NRZI (EIA RS-485)				
		CRC (X ¹⁶ +X ¹² +X ⁵ +1)				
		HDLC				
		1~64				
		3				
		156Kbps	625Kbps	2.5Mbps	5Mbps	10Mbps
		1200m	900m	400m	160m	100m
	0.2m					
	42 (1 /), (2 / 32), 가					
		CC-Link				
	0~55 (), : -20~65 ()					
	90%RH (가), : 90%RH (가)					
	(), 가 . 가 . 가					
	1000m					
	5.9m/s ²					
	(kg)	0.3				

CP

CC-Link

MR-J2S-T01

(1) : 3

- No. :
No. 「MR-J2S-CP ()」
가
No. :
CC-Link
No. ,가
- :
CC-Link
No.1 가

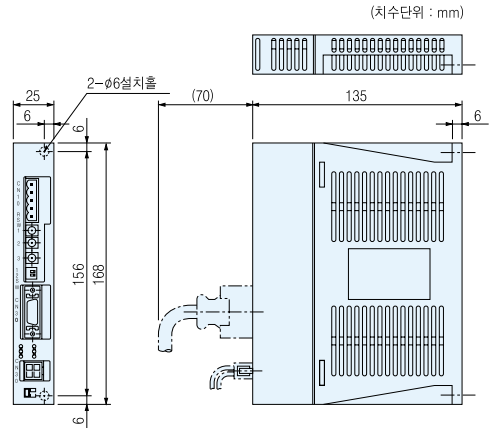

(2)

- 「 ON 」, 「 MR-J2S-CP() 」, 「 」

MR-J2S-CL

- 16 가
- 32 가
- 120 가
- MR Configurator()MRZJW3-SETUP161
- () 가

MR-J2S-CL

<DI/O >

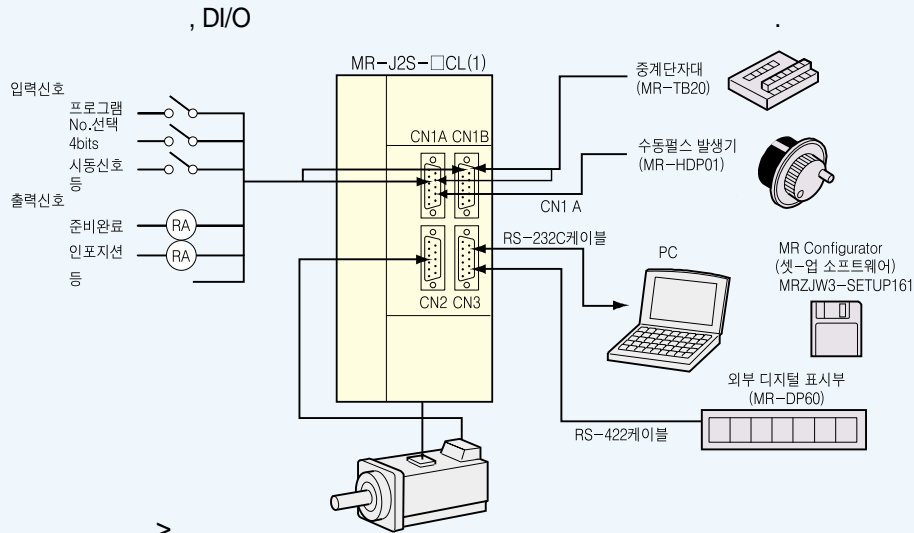

<RS-422 >

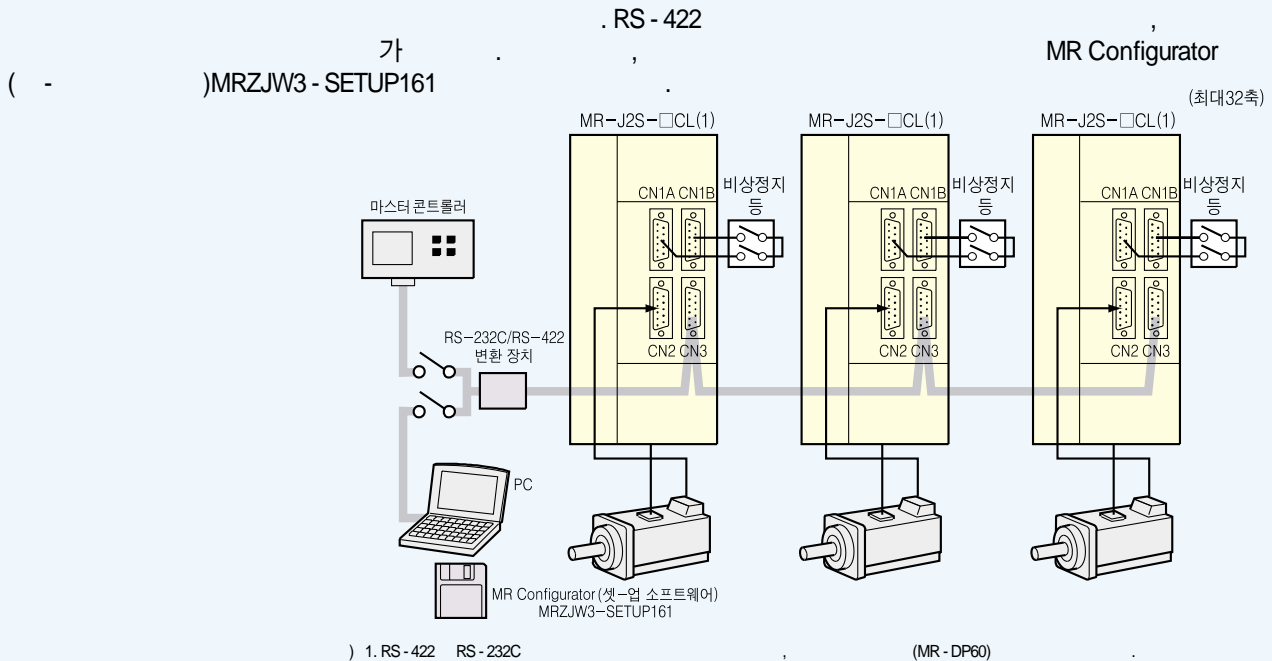

< RS-422 (RS-232C) >

- 9600/19200/38400/57600 (bps)
- bit : 1bit bit : 8bit
- bit : 1bit bit : 1bit
- 2

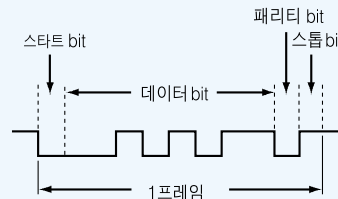

MR-J2S-CL

MR-J2S-CL

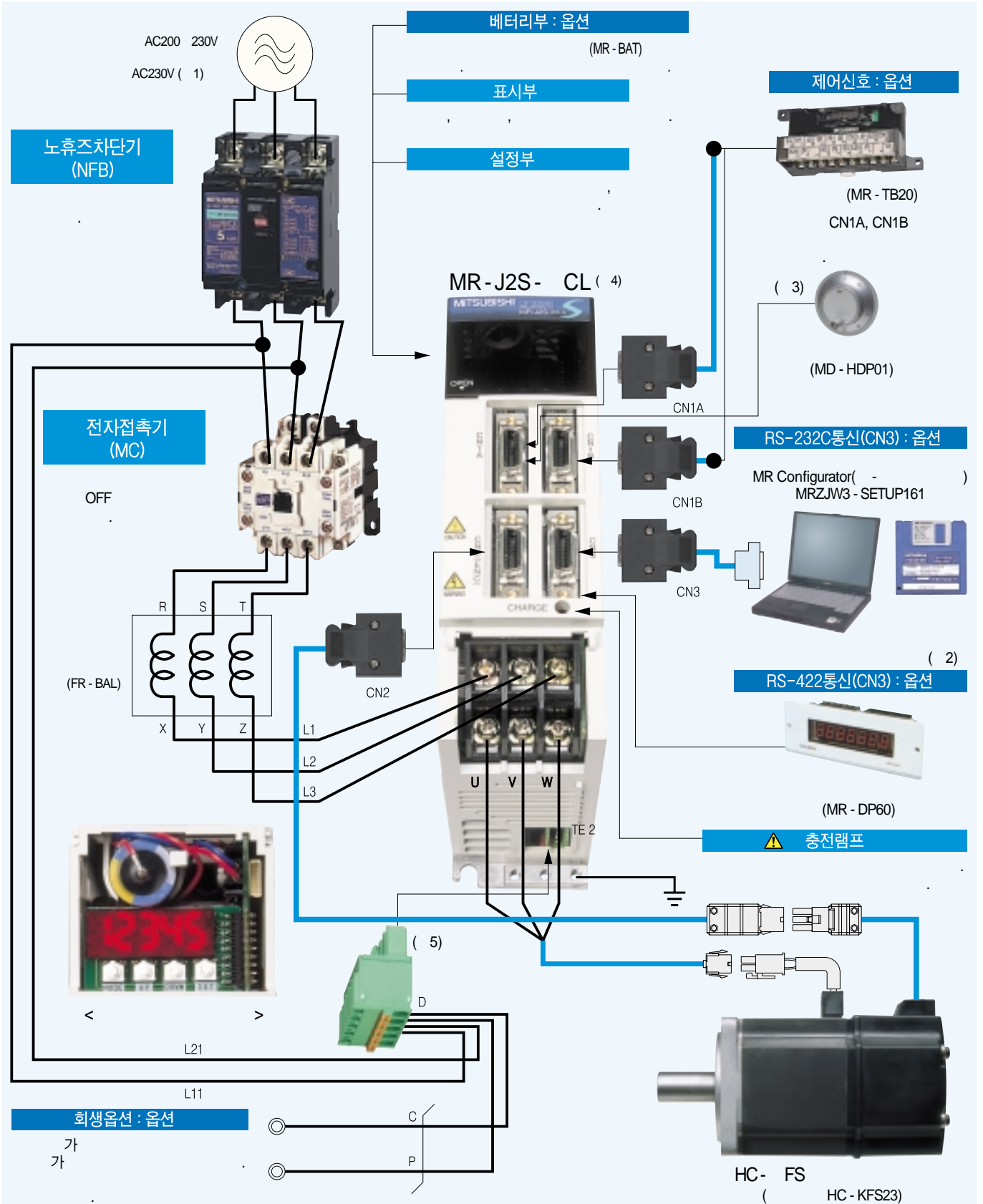

- 1. AC230V
- 2. RS-232 RS-422 RS-422
- 3. CN1 (MR-J2CN1) (MR-J2CN1)
- 4. MR-J2S-350CL .MR-J2S-500CL (MR-J2S-CL-RT)
- 5. MR-J2S-100CL

,가

					(7)
SPN (1)		SPN ()	0~	r/min	
STA(2)	가	STA ()	0~20000	ms	가
STB(2)		STB ()	0~20000	ms	
STC(2)	가	STC ()	0~20000	ms	가
STD(2)	S 가	STD ()	0~100	ms	S 가
MOV		MOV ()	-999999 ~999999	$\times 10^{\text{STM}} \mu\text{m}^{(6)}$	
MOVA		MOVA ()	-999999 ~999999	$\times 10^{\text{STM}} \mu\text{m}^{(6)}$	[MOVI]
MOVI		MOVI ()	-999999 ~999999	$\times 10^{\text{STM}} \mu\text{m}^{(6)}$	
MOVIA		MOVIA ()	-999999 ~999999	$\times 10^{\text{STM}} \mu\text{m}^{(6)}$	[MOVI]
SYNC (3)	ON	SYNC ()	1~3	-	SYNC (SOUT) 3(P13) ON 1(P11) ~
OUTON (3,4)	ON	OUTON ()	1~3	-	1(OUT1)~ No.74~No.76 ON 3(OUT3) ON OFF
OUTOF (3)	OFF	OUTOF()	1~3	-	[OUTON] ON 1(OUT1) ~ 3(OUT3) OFF
TRIP (3)		TRIP ()	-999999 ~999999	$\times 10^{\text{STM}} \mu\text{m}^{(6)}$	
TRIPI (3)		TRIPI ()	-999999 ~999999	$\times 10^{\text{STM}} \mu\text{m}^{(6)}$	[MOVI, MOVIA] [MOVI, MOVIA] [TRIPI] [MOVI, MOVIA]
ITP (3,5)		ITP ()	0 ~999999	$\times 10^{\text{STM}} \mu\text{m}^{(6)}$	[SYNC]
COUNT (3)		COUNT ()	-999999 ~999999	pulse	[COUNT] [COUNT(0)]
FOR NEXT		FOR () NEXT	0, 1~10000		[FOR()] [NEXT] [FOR(0)]
LPOS (3)		LPOS	-	-	(LPS)
TIM		TIM ()	1~2000	$\times 10\text{ms}$	
ZRT		ZRT	-	-	
TIMES		TIMES ()	0, 1~10000		[TIMES()] [TIMES(0)]
STOP		STOP	-	-	

1. [SPN] [MOV, MOVA, MOVI, MOVIA]
2. [STA, STB, STC, STD] [MOV, MOVI]
3. [SYNC, OUTON, OUTOF, TRIP, TRIPI, ITP, COUNT, LPOS]
4. No.74~No.76 ON
5. 가 [ITP]
6. STM
7. (R1~R4, D1~D4)
8. 「MR-J2S- CL

< 1 >

,가 ,

SPN(1000)	1000(r/min)	} (1)
STA(200)	가 200(ms)	
STB(300)	300(ms)	
MOV(1000)	1000(× 10 ⁵ TMμm)	
TIM(10)	100(ms)	
MOV(2500)	2500(× 10 ⁵ TMμm)	
STOP		

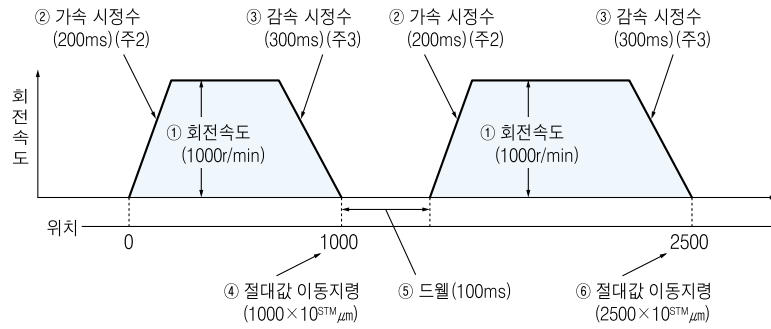

1. . .
2. . .
3. . .

< 2 >

[FOR()] [NEXT]

SPN(1000)	1000(r/min)
STC(20)	가 20(ms)
MOV(1000)	1000(× 10 ⁵ TMμm)
TIM(10)	100(ms)
FOR(3)	3()
MOVI(100)	100(× 10 ⁵ TMμm)
TIM(10)	100(ms)
NEXT	
STOP	

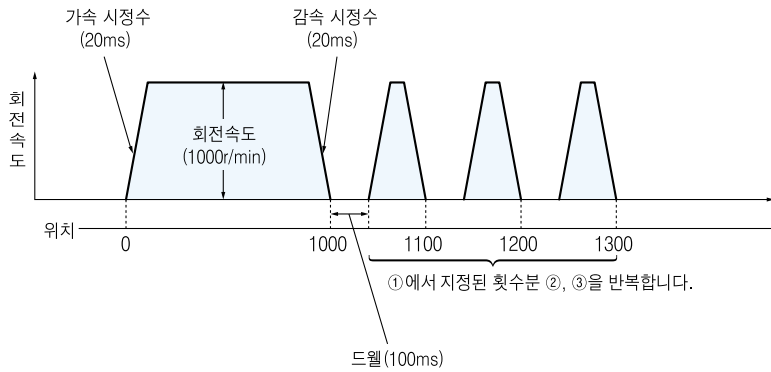

MR-J2S-CL()

MR-J2S-		10CL	20CL	40CL	60CL	70CL (-U)	100CL	200CL	350CL	500CL	700CL	10CL1	20CL1	40CL1
(1)	AC200~230V/50, 60Hz AC230V/50, 60Hz(2)					AC200~230V/50, 60Hz(2)					AC100~120V / 50, 60Hz(2)			
	AC200~230V : AC170~253V AC230V : AC207~253V		AC170~253V			AC170~253V			AC85~127V					
		±5%												
		PWM												
		(3)												
		, , , , , , , , , , , , , , , ,												
		(-)												
		: 120												
		1 : ±1(μm)~±999.999(mm)												
		, 가 , S 가												
		S 가 No.14												
J O G	RS - 422 (RS - 232C)													
	: ×1, ×10, ×100													
			Z 가 ,			가 ,			가 ,			가		
			가 ,			가 ,			가 ,			가		
			가 ,			가 ,			가 ,			가		
			가			가 ,			가 ,			가		
	(ON)		ON (SON) ON			가								
	(後)		가 ,			가 ,			가					
	(前)		가 ,			가 ,			가					
			가 ,			Z 가 ,			가					
					(IP00)			(IP00)			(IP00)			
		0~55 (),			: -20~65 ()									
		90%RH (가),			: 90%RH (가)									
		() ,			가 . 가 . 가									
		1000m			5.9m/s ²									
(kg)		0.7	0.7	1.1	1.1	1.7	1.7	2.0	2.0	4.9	7.2	0.7	0.7	1.1

1.)
 2.)
 3. (MR-J2S- CL-ED MR-J2S- CL1-ED) 가 .

MR-J2S-	10CL~70CL	100CL~350CL	500CL, 700CL	10CL1~40CL1
	P.30			
/	P.31	P.31	P.31	P.31
CN2	P.33	P.33 , P.34		P.33
CN3/CN4/CON2	P.35			

MR-J2S- A(1)/MR-J2S- A(4) :

QD75D

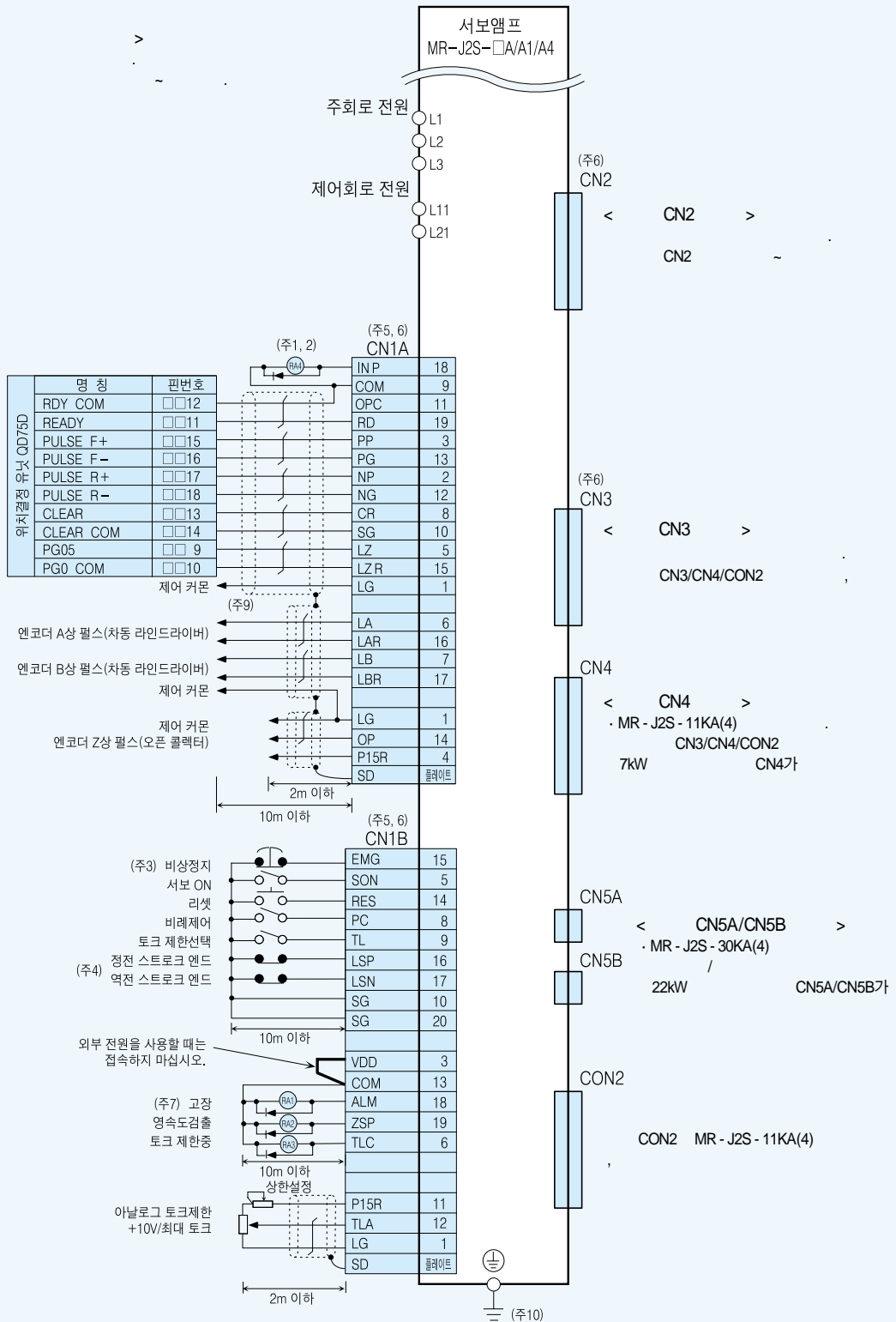

1. 가 가 가 가
2. 80mA 가 .80mA 가
3. EMG (b)
4. (LSP, LSN) (b)
- 5.
6. CN1A, CN1B, CN2 CN3
7. (ALM) ON
8. ()
9. LG (PE)
10. (PE)

MR-J2S- A(1)/MR-J2S- A(4) :

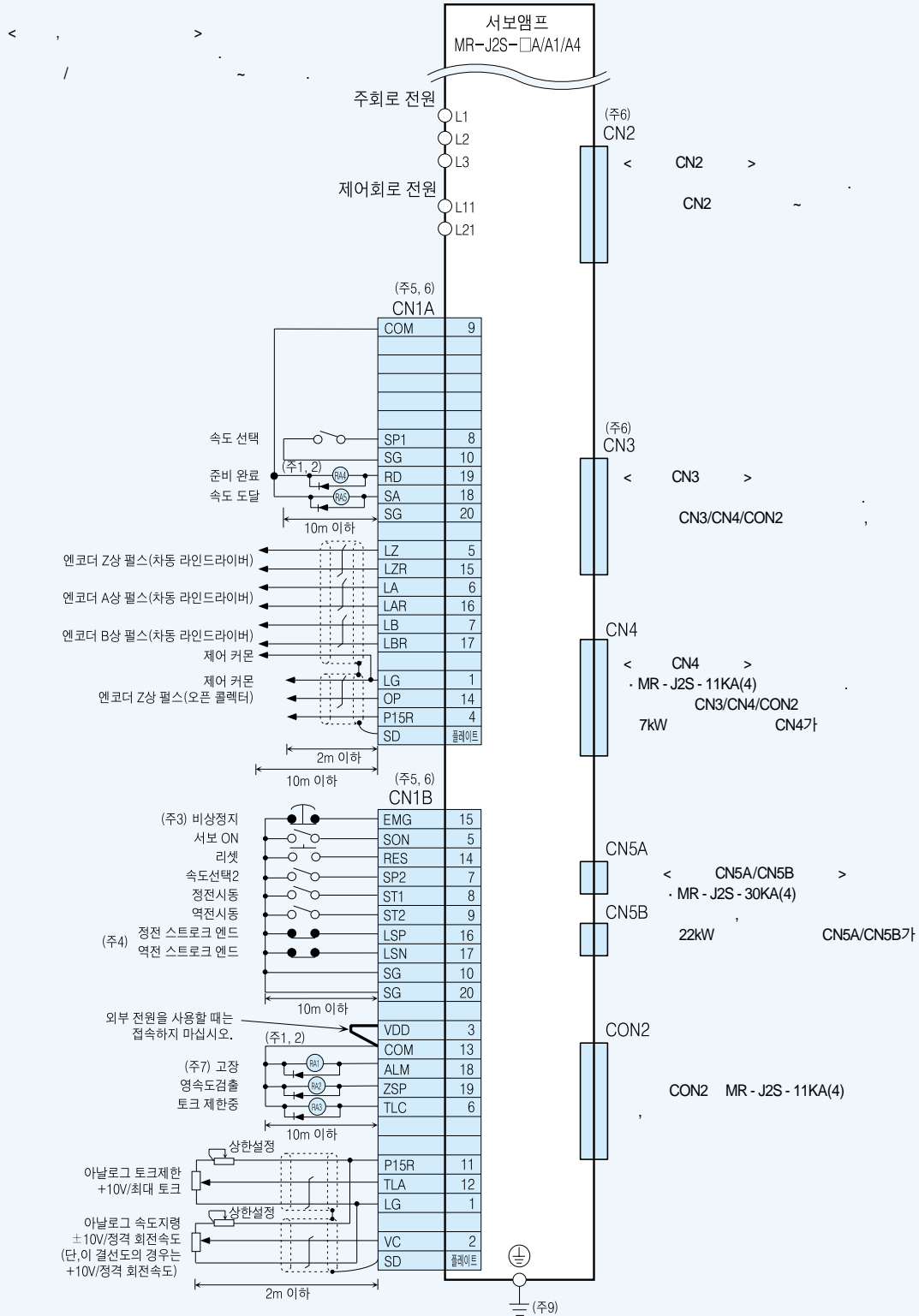

1. 가 가 가 가
2. 80mA 가 .80mA 가
3. EMG (b)
4. (LSP,LSN) .(b)
- 5.
6. CN1A, CN1B, CN2 CN3
7. (ALM) ON
8. () (PE)
9. (PE) (PE)

MR-J2S- A(1)/MR-J2S- A(4) :

A

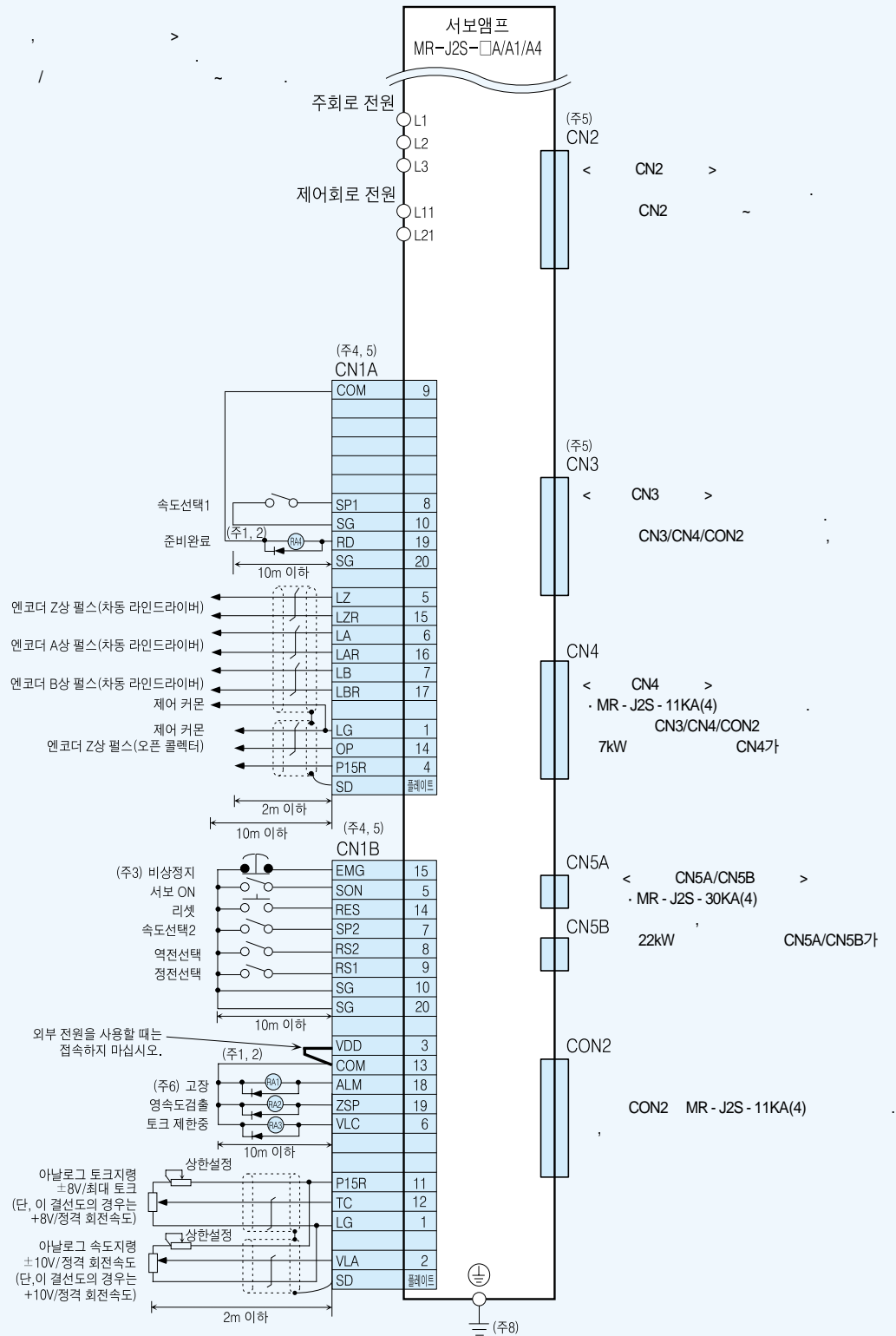

1. 가 가 가
2. 80mA 가 .80mA 가
3. EMG (b)
- 4.
5. CN1A, CN1B, CN2 CN3
6. (ALM) ON ()
7. (PE) (PE)
- 8.

MR-J2S- B(1)/MR-J2S- B(4)

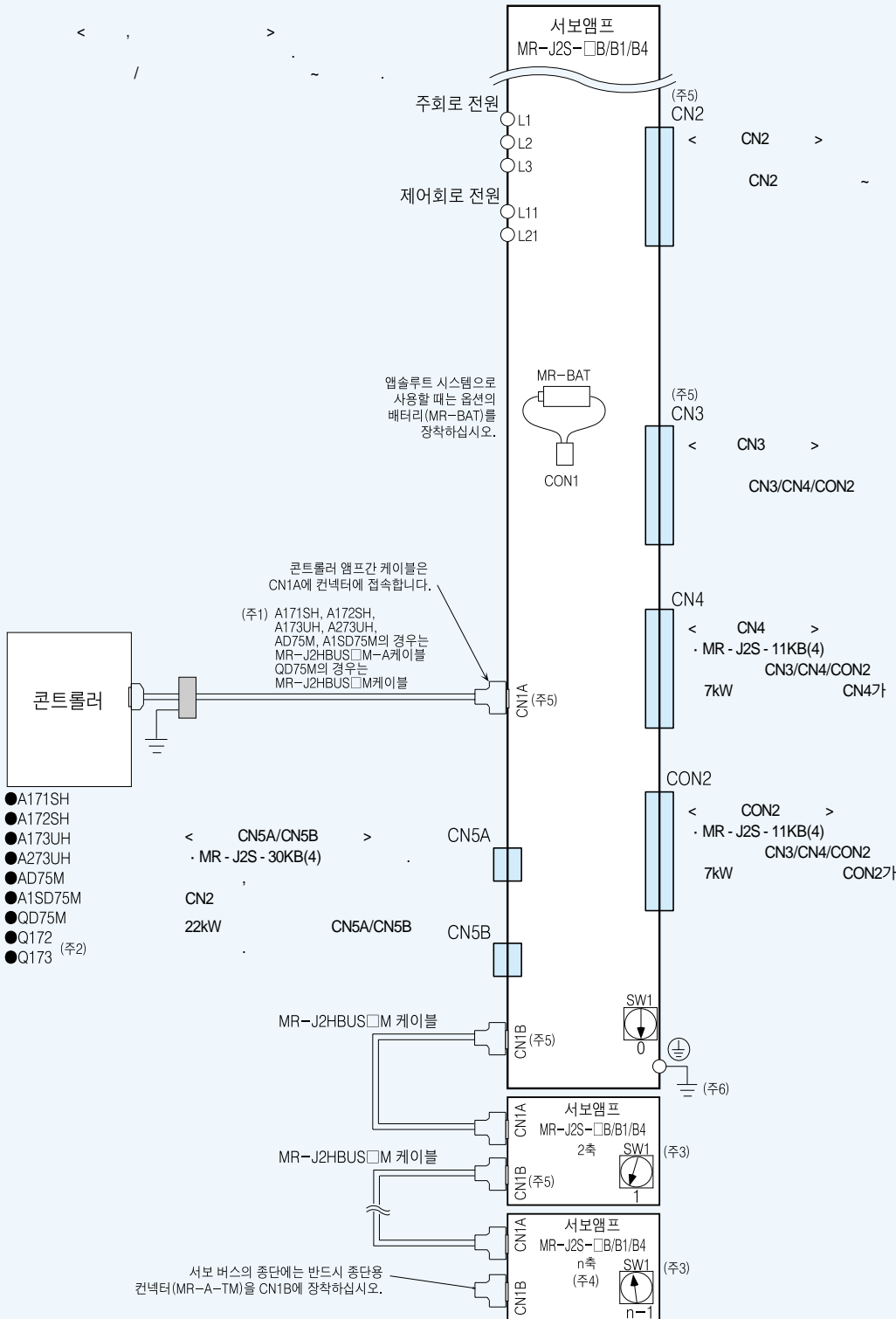

1. MR-J2HBUS M-A, MR-J2HBUS M 30m
2. Q172/Q173- Q
3. 2
4. 8 (n=1~8) MR-H BN
5. CN1A, CN1B, CN2 CN3
6. (PE) (PE)

(3-4)

MR-J2S- CP(1)

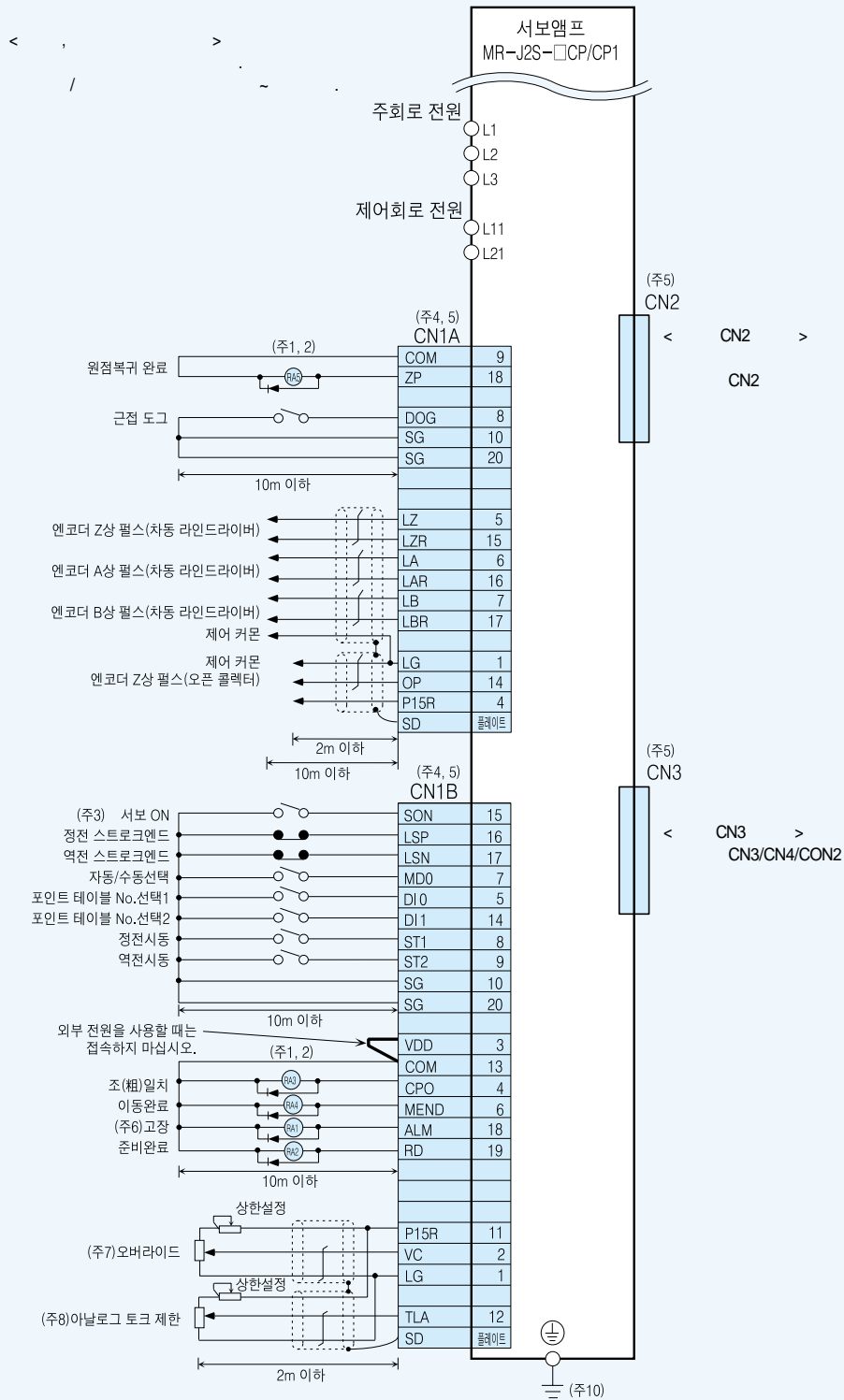

1. 가 가 가
2. 80mA 가 .80mA 가
3. (LSP, LSN) (b)
- 4.
5. CN1A, CN1B, CN2 CN3
6. (ALM) ON
7. (VC) (OVR) 가
8. (TLA) (TL) 가
9. () ()
10. (PE) (PE)

MR-J2S- CP(1)-S084

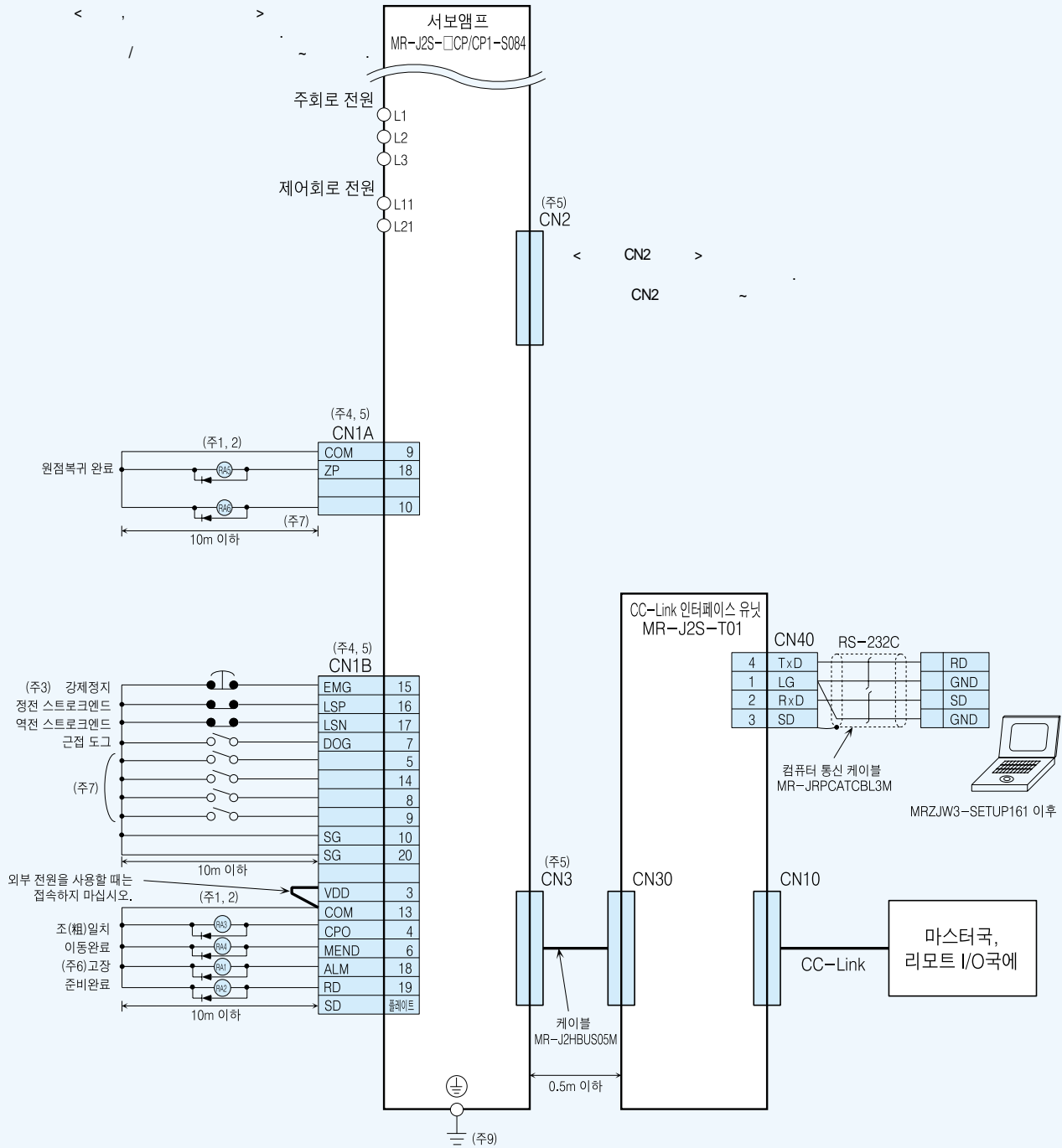

1. 가 가 가 가
2. 80mA 가 .80mA 가
3. (LSP, LSN) (b)
- 4.
5. CN1A, CN1B, CN2 CN3
6. (ALM) ON
- 7.
8. ()
9. (PE) (PE)

MR-J2S- CL(1)

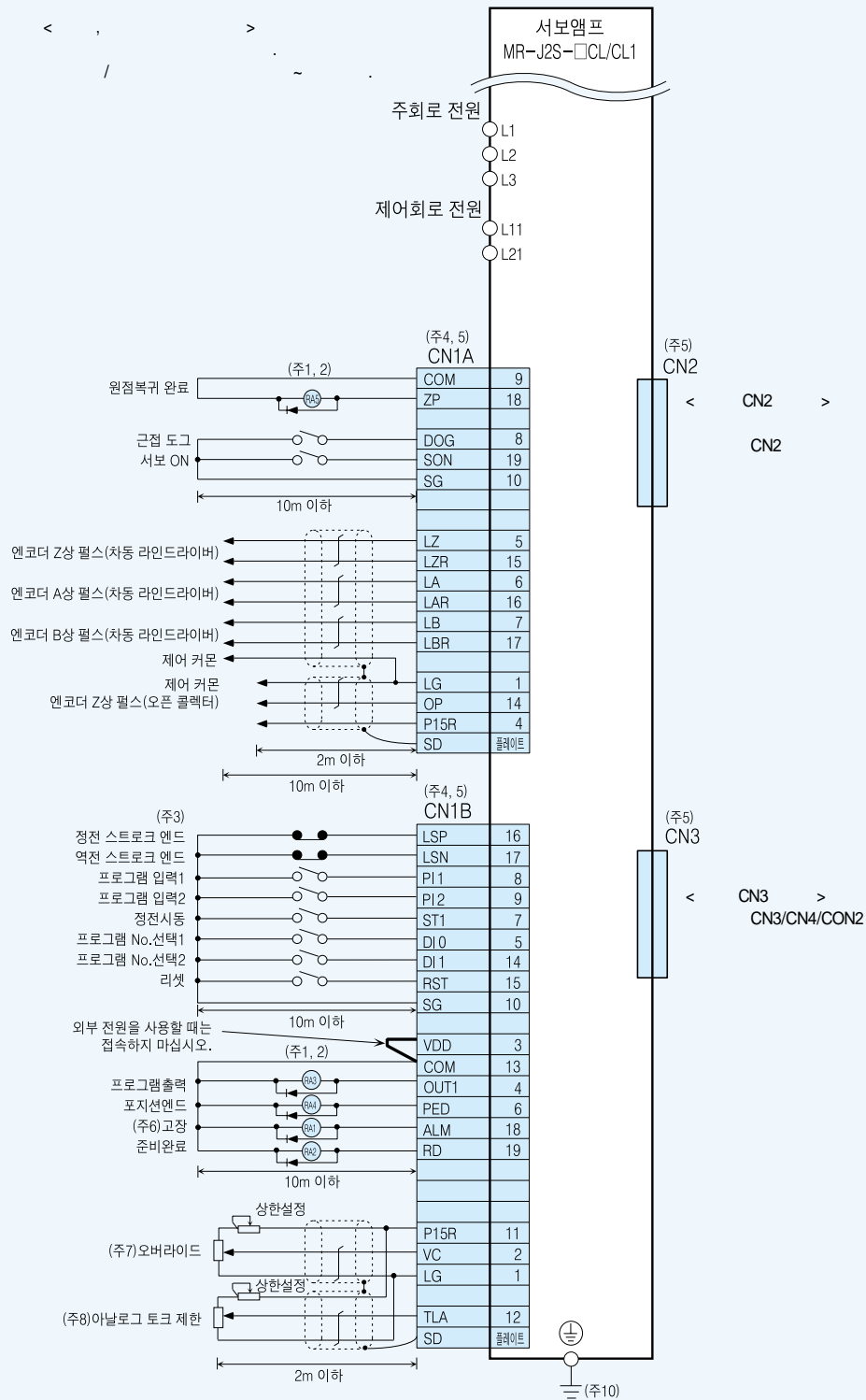

1. 가 가 가
2. 80mA 가 80mA 가
3. (LSP, LSN) (b)
4. 가
5. CN1A, CN1B, CN2 CN3
6. (ALM) ON 가
7. (VC) (OVR) 가
8. (TLA) (TL) 가
9. 가
10. (PE) (PE)

100V

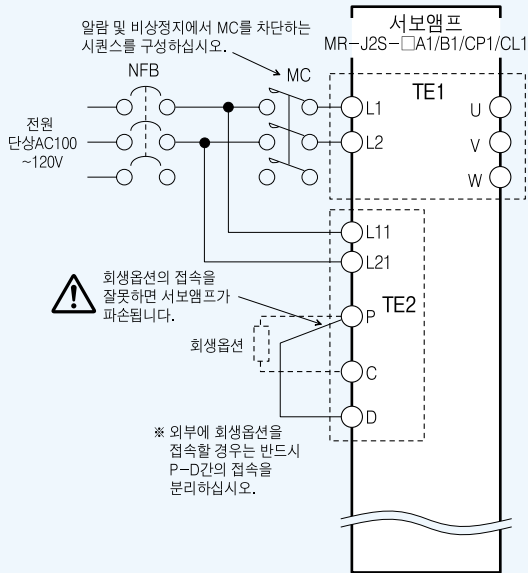

230V

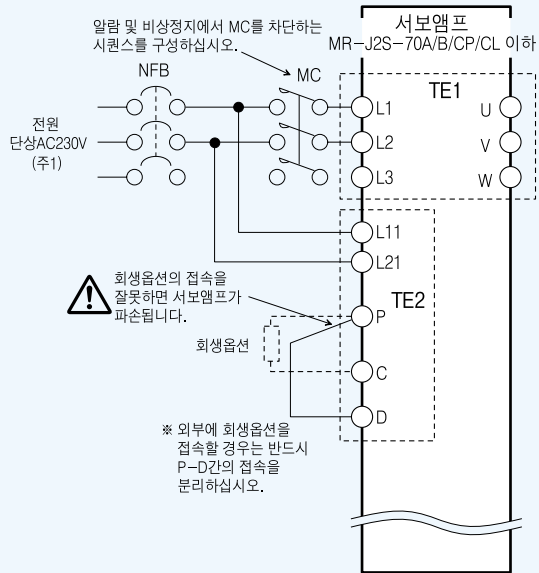

200V 3.5kW

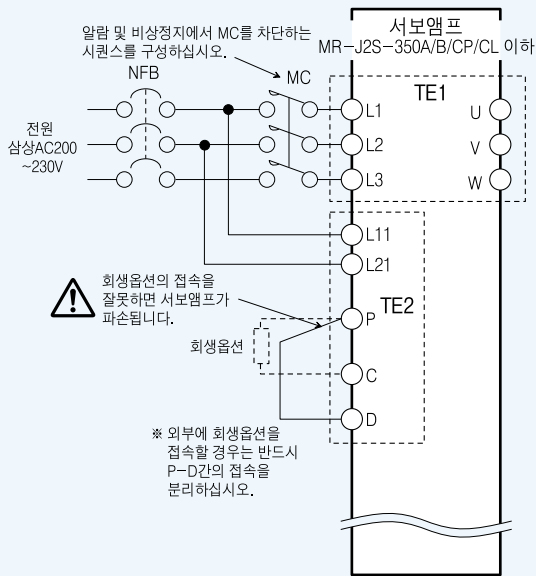

200V 5, 7kW

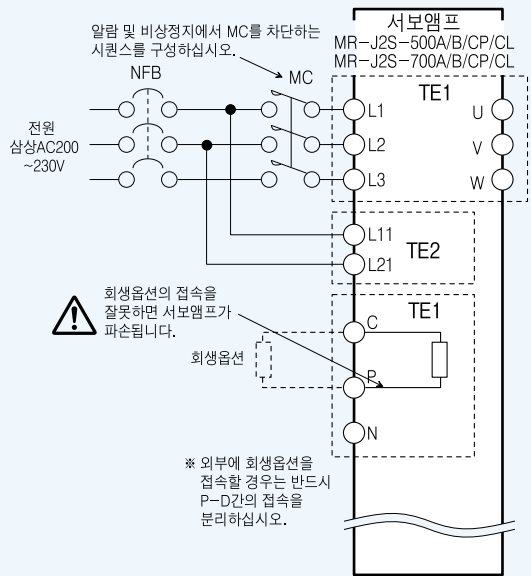

) 1. AC230V L1, L2 , L3

AC230V MR - J2S - 70A/B/CP/CL

200V 400V 11~22 kW

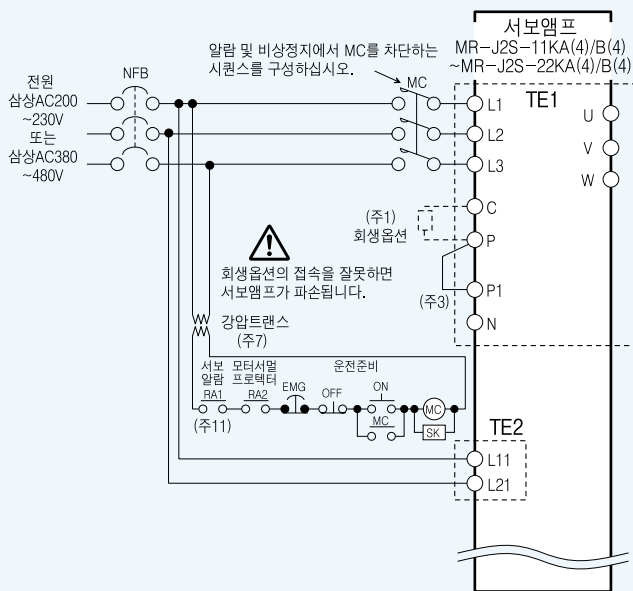

200V 400V 30 kW

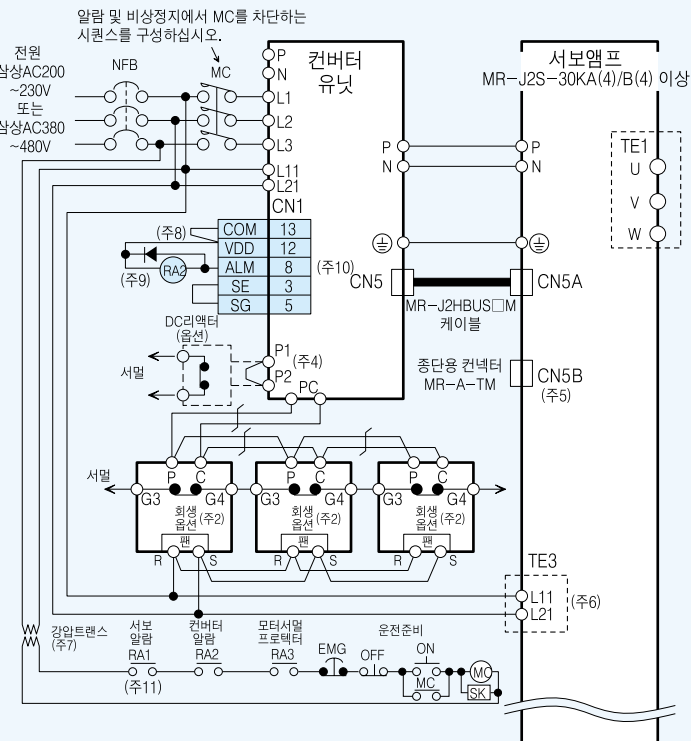

400V 2kW

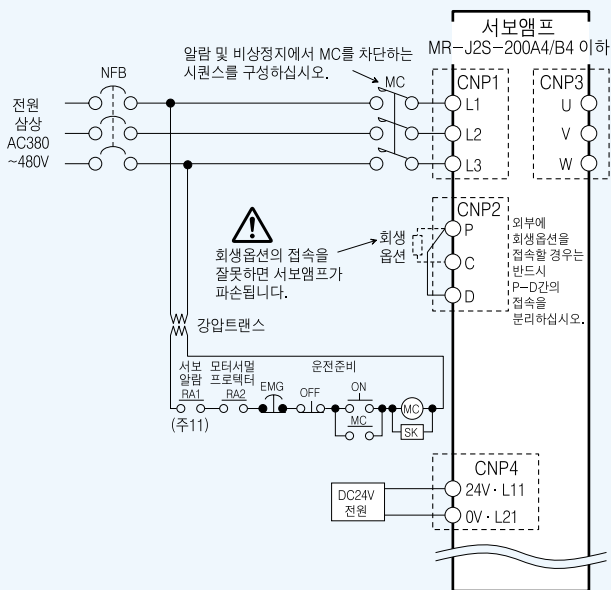

400V 3.5~7kW

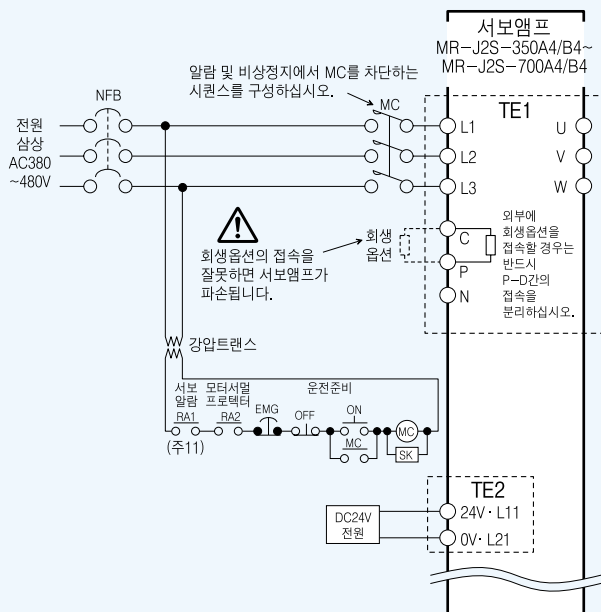

- 1. 11kW
- 2. MR-RB137(200V), MR-RB138-4(400V) MR-RB137 MR-RB138-4 3 가1 (W 3900W)
- 3. DC P-P1
- 4. DC P1-P2
- 5. (MR-A-TM) CN5B
- 6. L11, L21 (相) L1, L2 가
- 7. 400V 200V 가 가 가 가
- 8. 가 가 가 가
- 9. 80mA 가 80mA
- 10. (ALM) ON 가 가
- 11. MC MR-J2S-A CP CL 「 」

CN2

HC-KFS, MFS, UFS3000r/min

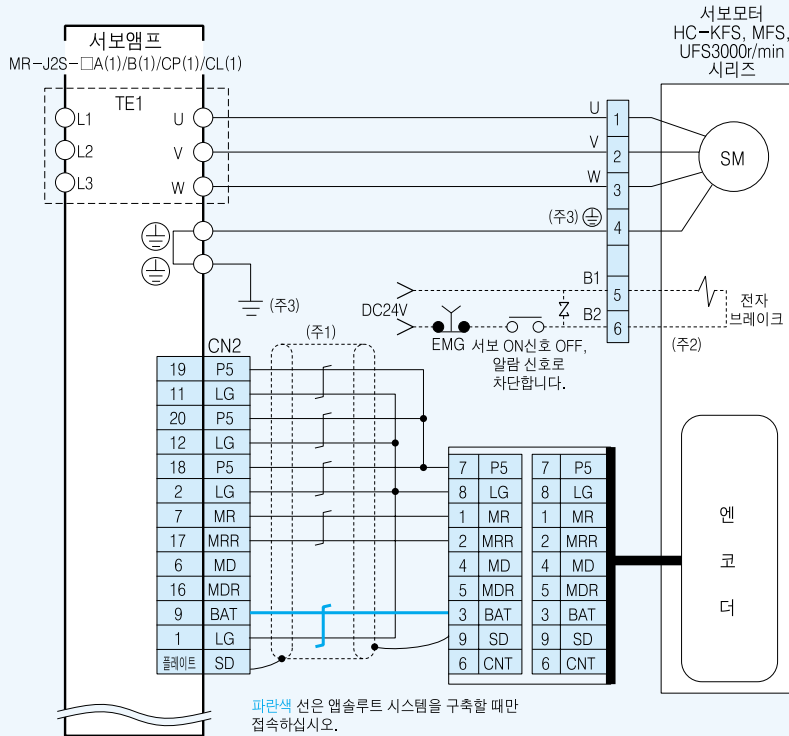

HC-SFS, LFS, RFS, UFS2000r/min

HA-LFS502, 702

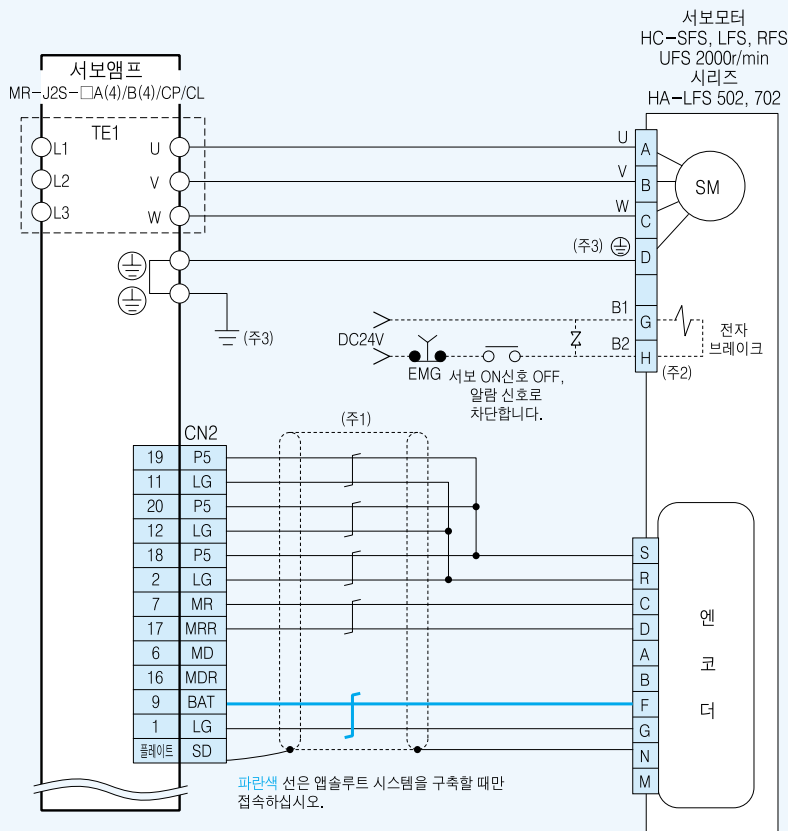

1. MR-J2S
2. HC-SFS121B-301B, 202(4)B-702(4)B, 203B, 353B, HC-LFS202B, 302B, HC-UFS202B-502B
3. (PE)

가

HA-LFS601(4), 701M(4), 801(4) HA-LFS 11kW

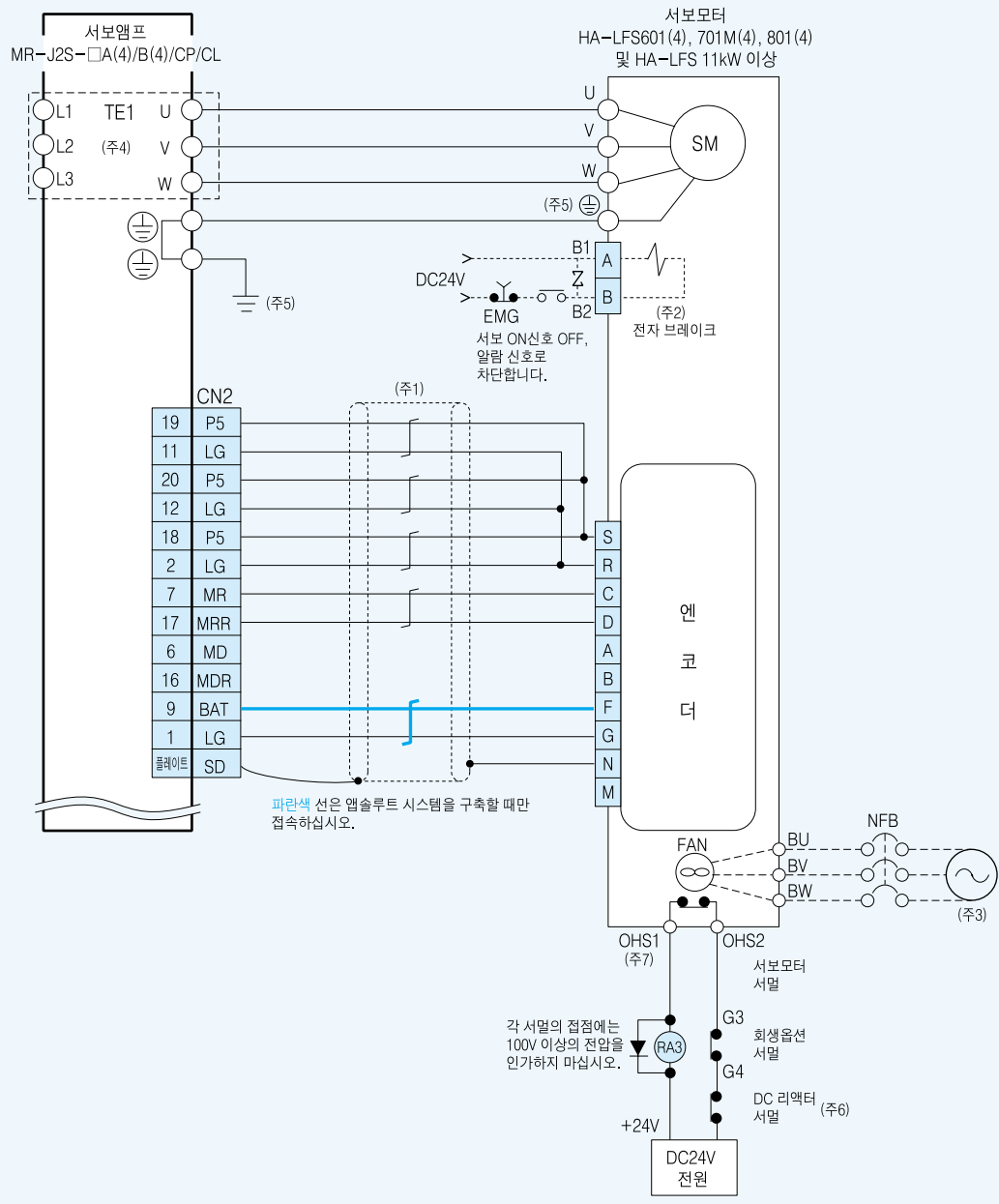

- 1. MR - J2S
- 2. L1, L2, L3
- 3. (PE)
- 4. MR - J2S - 30KA(4)/B(4)
- 5. HA - LFS 30K
- 6. OHS1 10mA, 3A
- 7. 가

CN3/CN4/CON2

MR-J2S-700A(4)/CP/CL

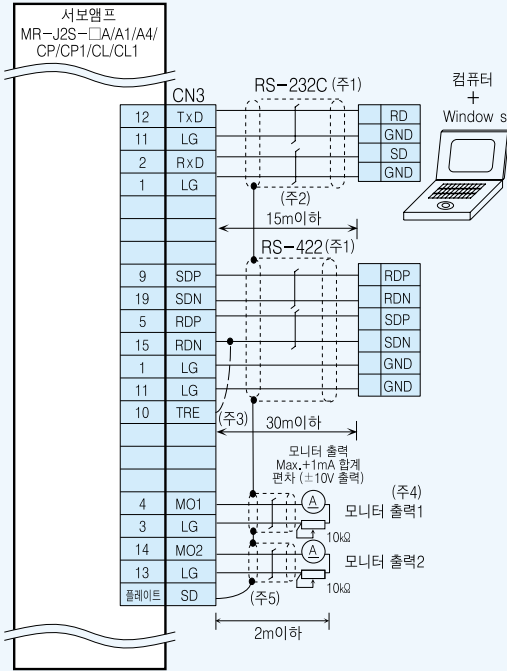

MR-J2S-11KA(4)

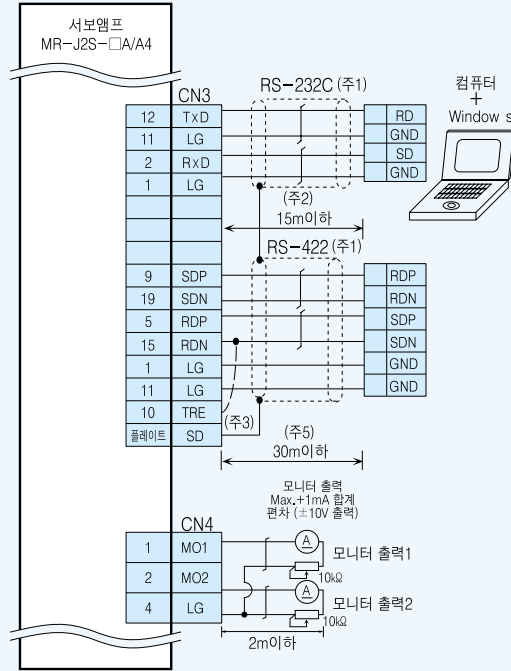

MR-J2S-700B(4)

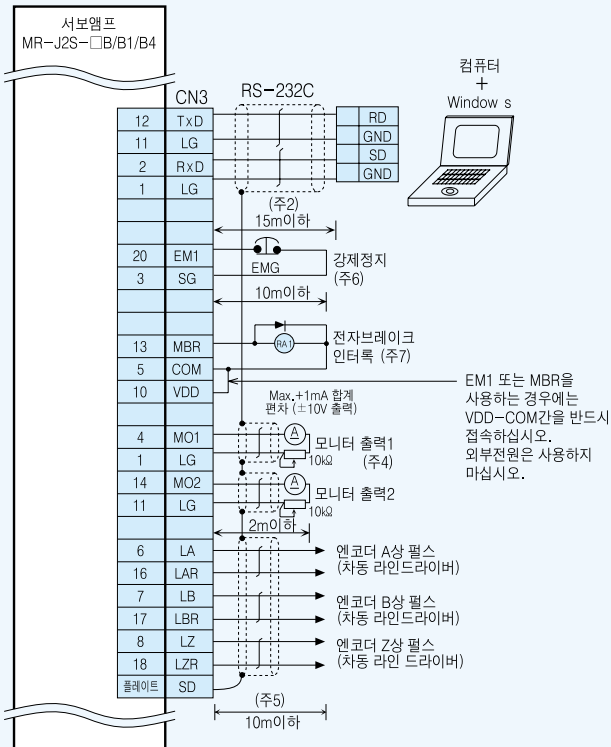

MR-J2S-11KB(4)

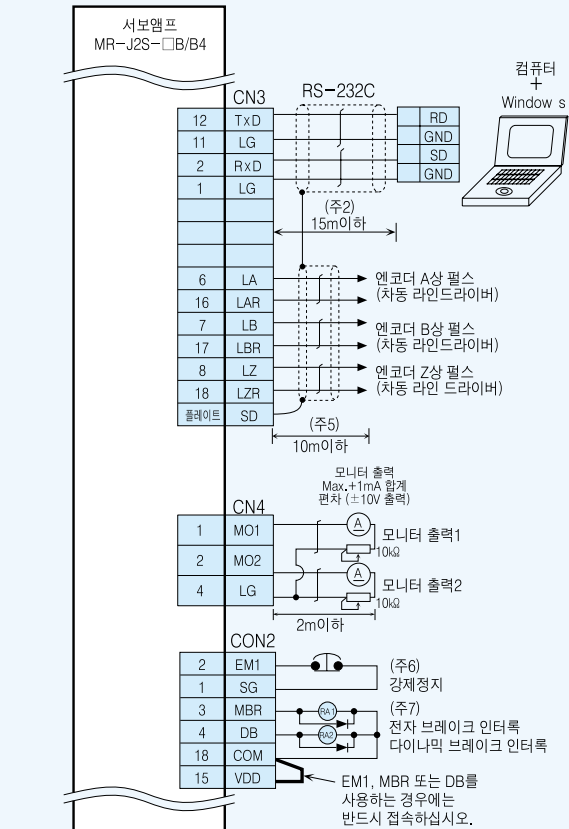

1. RS-232 RS-422
2. RS-232C 38,400bps 15m 가
3. TRE RDN 3m
4. 1(MO1), 2(MO2)
5. AD75M, A1SD75M, QD75M, Q172, Q173
6. EM1 - SG 가 가
- 7.

(MR-J2CN3TM)

. A171SH, A172SH, A173UH, A273UH
No.23

HC-KFS

		HC-KFS ()					HC-KFS ()	
HC-KFS		053(B)	13(B)	23(B)	43(B)	73(B)	46	410
(9) MR-J2S-		10A(1)/B(1)/CP(1)/CL(1)		20A(1)/B(1) CP(1)/CL(1)	40A(1)/B(1) CP(1)/CL(1)	70A/B/CP/CL	70A/B/CP/CL -U005	70A/B/CP/CL -U006
(2) (kVA)		0.3	0.3	0.5	0.9	1.3	0.9	0.9
(W)		50	100	200	400	750	400	
(N·m)		0.16	0.32	0.64	1.3	2.4	0.64	0.38
(N·m)		0.48	0.95	1.9	3.8	7.2	2.87	1.91
(r/min)		3000			6000		10000	
(r/min)		4500			6000		10000	
(r/min)		5175			6900		11500	
(kW/s)		4.78	12.1	15.8	36.7	37.7	6.4	3.1
(A)		0.83	0.71	1.1	2.3	5.8	2.9	2.9
(A)		2.5	2.2	3.4	6.9	18.6	12.9	14.5
(3, 4) (/)		(5)	(5)	(5)	220	190	110	55
() B	J (× 10 ⁻⁴ kg · m ²)	0.053(0.056)	0.084(0.087)	0.260(0.310)	0.460(0.510)	1.51(1.635)	0.64	0.47
(6)		15		24	22	15		
		17			(1		: 131072p/rev)	
		(IP55)(1, 7)						
		0 40 (), : -15 70 ()						
		80%RH (가), : 90%RH (가)						
		(), 가 . 가 . 가						
/ (5)		1000m / X, Y : 49m/s ²					1000m / X, Y : 19.6m/s ²	
(kg) () B		0.4(0.75)	0.53(0.89)	0.99(1.6)	1.45(2.1)	3.0(4.0)	1.5	1.5

- 1.
- 2.
3. 가1 (/) 2 1/(m+1) .(m= /) .
가 가 (가) (W) .
: <http://www.mitsubishi-automation.co.kr>
4. 600W 가
5. 가 15
- 6.
7. IP44
8. (bracket) 
9. MR-J2S- CP(1)-S084 MR-J2S- CP(1)

HC-KFS

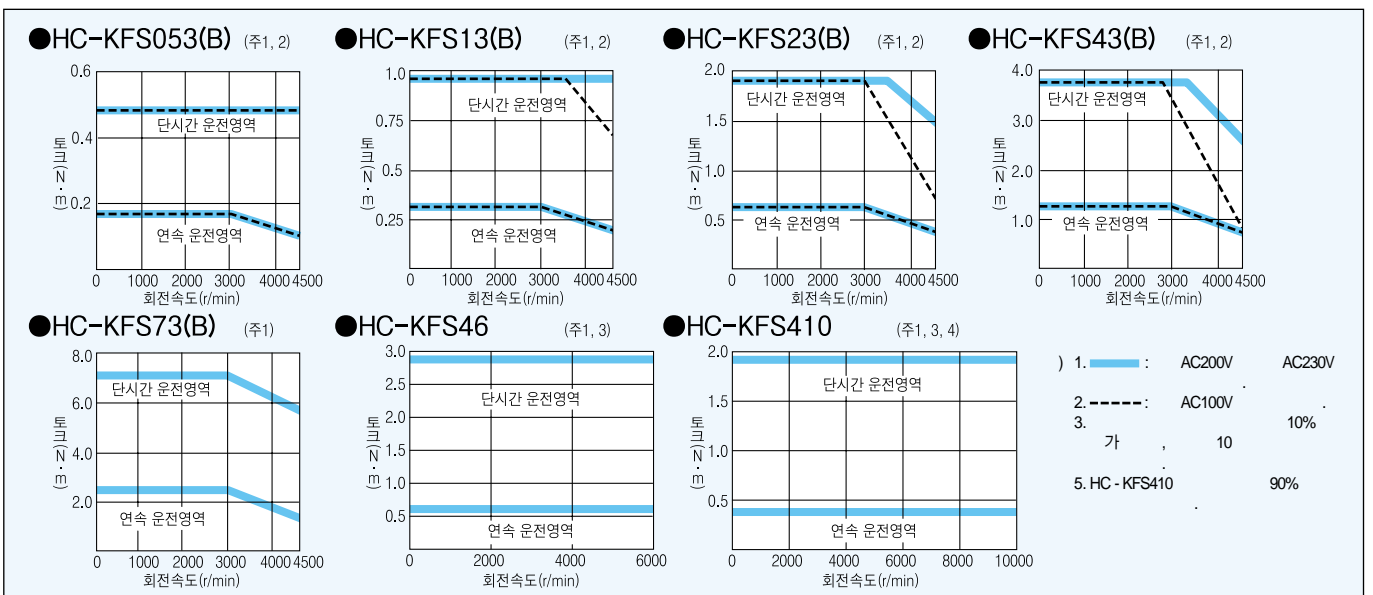

HC-MFS

		HC-MFS ()				
		053 (B)	13 (B)	23 (B)	43 (B)	73 (B)
		10A(1)/B(1)/CP(1)/CL(1)		20A(1)/B(1)/CP(1)/CL(1)	40A(1)/B(1)/CP(1)/CL(1)	70A/B/CP/CL
(2)	(kVA)	0.3	0.3	0.5	0.9	1.3
	(W)	50	100	200	400	750
	(N · m)	0.16	0.32	0.64	1.3	2.4
	(N · m)	0.48	0.95	1.9	3.8	7.2
	(r/min)	3000				
	(r/min)	4500				
	(r/min)	5175				
	(kW/s)	13.47	34.13	46.02	116.55	94.43
	(A)	0.85		1.5	2.8	5.1
	(A)	2.6		5.0	9.0	18
(3, 4)	(/)	(5)	(5)	(5)	1010	400
() B	J (× 10 ⁻⁴ kg · m ²)	0.019(0.022)	0.03(0.032)	0.088(0.136)	0.143(0.191)	0.6(0.725)
		30 (6)				
		17 (1 : 131072p/rev)				
		(IP55)(1, 7)				
		0 40 (), : -15 70 ()				
		80%RH (가), : 90%RH (가)				
		(), 가 . 가 . 가				
	/ (8)	1000m / X, Y : 49m/s ²				
(kg)	() B	0.4(0.75)	0.53(0.89)	0.99(1.6)	1.45(2.1)	3.0(4.0)

- 1.
- 2.
3. 가1 (/) 2 1/(m+1) (m= /) .
- 가 가 (가) (W) .
- : <http://www.mitsubishi-automation.co.kr>
4. 600W 가 30
- 5.
- 6.
7. IP44
8. (bracket) 
9. MR-J2S- CP(1)-S084 MR-J2S- CP(1)

HC-MFS

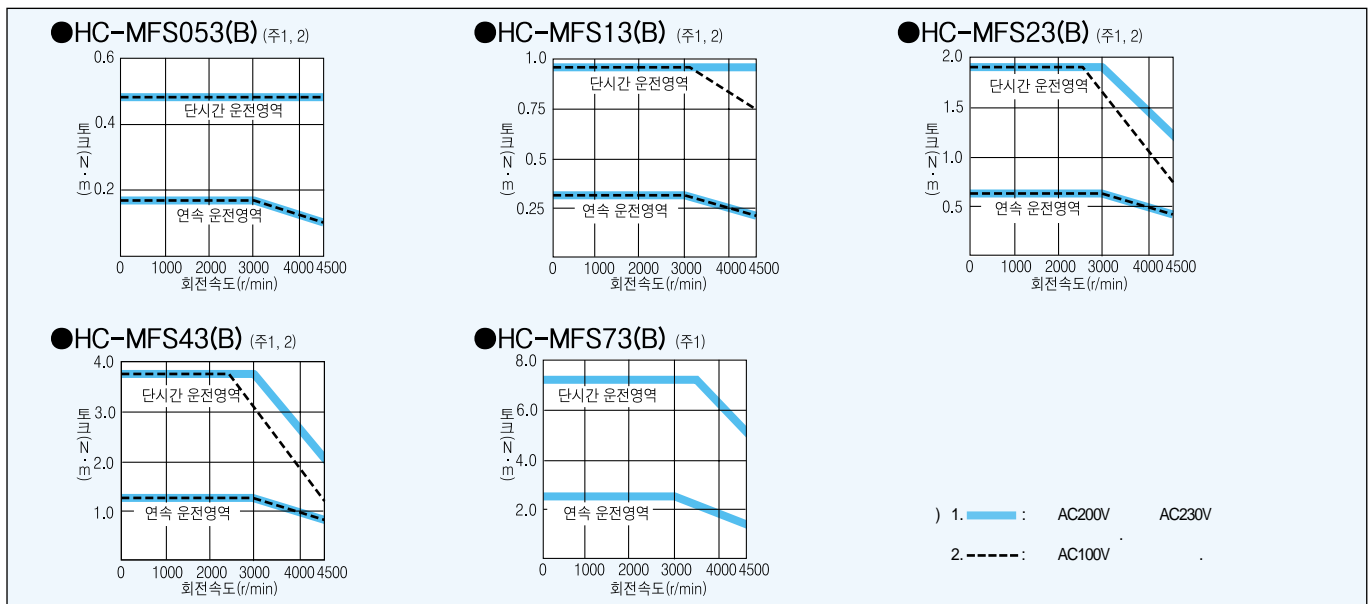

HC-LFS

HC-LFS		HC-LFS ()				
HC-LFS		52(B)	102(B)	152(B)	202(B)	302(B)
(6) MR - J2S -		60A/B/CP/CL	100A/B/CP/CL	200A/B/CP/CL	350A/B/CP/CL	500A/B/CP/CL
(1) (kVA)		1.0	1.7	2.5	3.5	4.8
(kW)		0.5	1.0	1.5	2.0	3.0
(N · m)		2.39	4.78	7.16	9.55	14.3
(N · m)		7.16	14.4	21.6	28.5	42.9
(r/min)		2000				
(r/min)		3000				
(r/min)		3450				
(kW/s)		17.9	49.7	80.1	41.5	56.8
(A)		3.2	5.9	9.9	14	23
(A)		9.6	18	30	42	69
(/)		115	160	425	120	70
() B	J (× 10 ⁻⁴ kg · m ²)	3.2(5.2)	4.6(6.6)	6.4(8.4)	22(32)	36(46)
		10 (4)				
		17 (1 : 131072p/rev)				
		(IP65)				
		0 40 (), : - 15 70 ()				
		80%RH (가), : 90%RH (가)				
		(), 가 . 가 . 가				
/ (8)		1000m / X : 9.8m/s ² , Y : 24.5m/s ²			1000m / X : 19.6m/s ² , Y : 49m/s ²	
(kg)	() B	6.5(9.0)	8.0(10.5)	10.0(12.5)	21(27)	28(34)

1. 가1
2. 가1 (/) 2 1/(m+1) .(m= /) .

가 가 가 (W)

: <http://www.mitsubishi-automation.co.kr>

3. 600W

4.

5. (bracket)

6. MR - J2S - CP(1) - S084

MR - J2S - CP(1)



HC-LFS

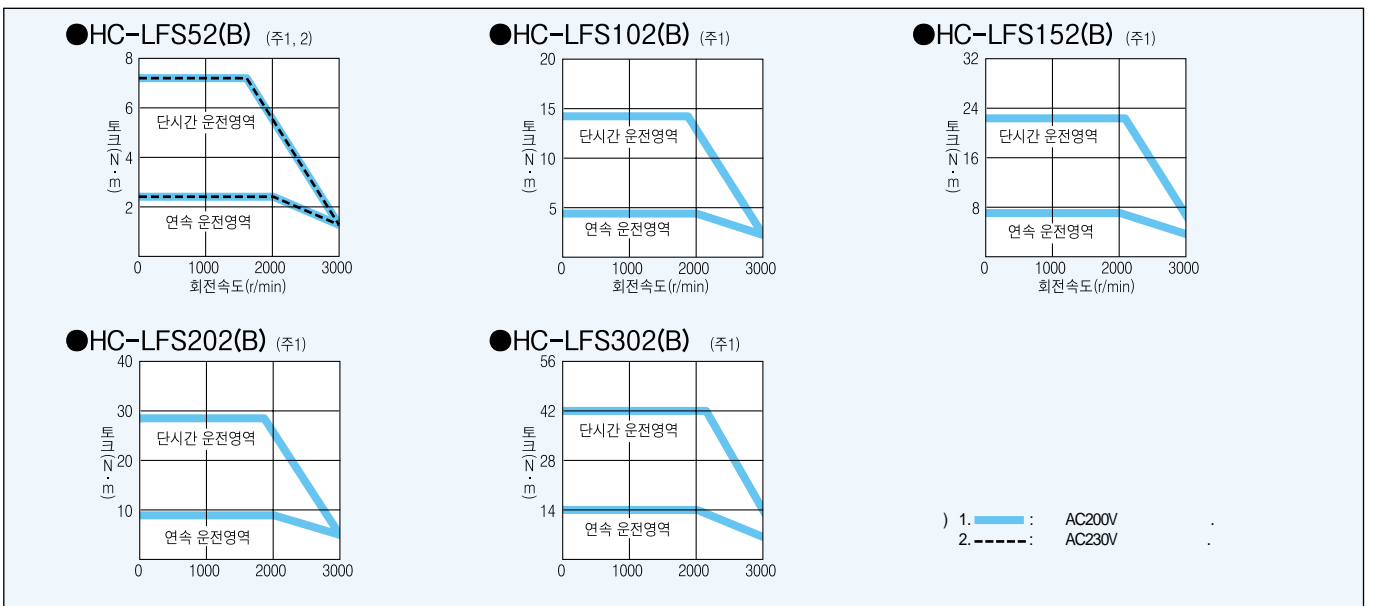

MELSERVO J2 Super

HC-SFS (200V)

		HC-SFS 1000r/min ()				HC-SFS 2000r/min ()		
HC-SFS		81(B)	121(B)	201(B)	301(B)	52(B)	102(B)	152(B)
(7) MR - J2S -		100A/B/CP/CL	200A/B/CP/CL		350A/B/CP/CL	60A/B/CP/CL	100A/B/CP/CL	200A/B/CP/CL
(1) (kVA)		1.5	2.1	3.5	4.8	1.0	1.7	2.5
(kW)		0.85	1.2	2.0	3.0	0.5	1.0	1.5
(N·m)		8.12	11.5	19.1	28.6	2.39	4.78	7.16
(N·m)		24.4	34.4	57.3	85.9	7.16	14.4	21.6
(r/min)		1000				2000		
(r/min)		1500	1200		3000			
(r/min)		1725	1380		3450			
(kW/s)		32.9	30.9	44.5	81.3	8.7	16.7	25.6
(A)		5.1	7.1	9.6	16	3.2	6	9
(A)		15.3	21.3	28.8	48	9.6	18	27
(/)		140	240	100	84	56	54	136
() B	J (× 10 ⁻⁴ kg · m ²)	20.0(22.0)	42.5(52.5)	82.0(92.0)	101(111)	6.6(8.6)	13.7(15.7)	20.0(22.0)
		15 (4)						
		17 (1 : 131072p/rev)						
		(IP65)				(IP65) (5)		
		0 40 (), : -15 70 ()						
		80%RH (가), : 90%RH (가)						
		(), 가 . 가 . . 가						
		1000m						
(6)	X, Y : 24.5m/s ²	X : 24.5m/s ² Y : 49m/s ²		X : 24.5m/s ² Y : 29.4m/s ²		X, Y : 24.5m/s ²		
(kg)	() B	9(11)	12(18)	19(25)	23(29)	5(7)	7(9)	9(11)

- 1.
 2. 가1 1/(m+1) . (m= /) .
- 가 가 가 가 (W)
- : <http://www.mitsubishi-automation.co.kr>
3. 600W 가

HC-SFS (200V)

●HC-SFS81(B) (주1)

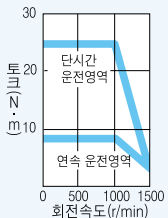

●HC-SFS121(B) (주1)

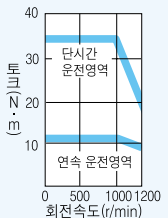

●HC-SFS201(B) (주1)

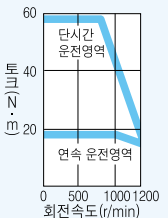

●HC-SFS301(B) (주1)

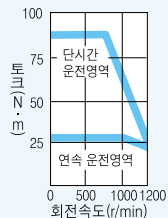

●HC-SFS52(B) (주1, 2)

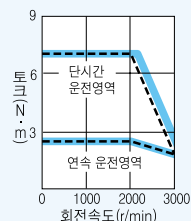

●HC-SFS102(B) (주1)

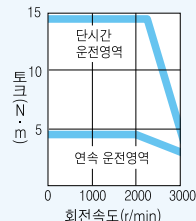

●HC-SFS152(B) (주1)

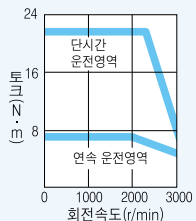

1. — : AC200V
2. - - - : AC230V

HC-SFS 2000r/min ()					HC-SFS 3000r/min ()				
202(B)	352(B)	502(B)	702(B)	53(B)	103(B)	153(B)	203(B)	353(B)	
200A/B/CP/CL	350A/B/CP/CL	500A/B/CP/CL	700A/B/CP/CL	60A/B/CP/CL	100A/B/CP/CL	200A/B/CP/CL		350A/B/CP/CL	
3.5	5.5	7.5	10.0	1.0	1.7	2.5	3.5	5.5	
2.0	3.5	5.0	7.0	0.5	1.0	1.5	2.0	3.5	
9.55	16.7	23.9	33.4	1.59	3.18	4.78	6.37	11.1	
28.5	50.1	71.6	100	4.77	9.55	14.3	19.1	33.4	
2000					3000				
2500			2000		3000				
2875			2300		3450				
21.5	34.1	56.5	69.7	3.8	7.4	11.4	9.5	15.1	
11	17	26	35	3.2	5.3	8.6	10.4	16.4	
33	51	84	105	9.6	15.9	25.8	31.2	49.2	
64	31	39	32	25	24	82	24	14	
42.5(52.5)	82.0(92.0)	101(111)	160(170)	6.6(8.6)	13.7(15.7)	20.0(22.0)	42.5(52.5)	82.0(92.0)	
15 (4)									
17 (1 : 131072p/rev)									
(IP65)(5)					(IP65)				
0 40 (), : -15 70 ()									
80%RH (가), : 90%RH (가)									
(), 가 . 가 . 가									
1000m									
X : 24.5m/s ² Y : 49m/s ²		X : 24.5m/s ² Y : 29.4m/s ²		X, Y : 24.5m/s ²			X : 24.5m/s ² Y : 49m/s ²		
12(18)	19(25)	23(29)	32(38)	5(7)	7(9)	9(11)	12(18)	19(25)	

- 4.
- 5.
- 6.
7. MR -J2S- CP(1) -S084

IP44

bracket

MR -J2S- CP(1)



●HC-SFS202(B) (주1)

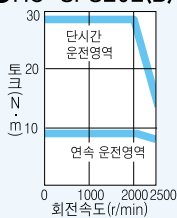

●HC-SFS352(B) (주1)

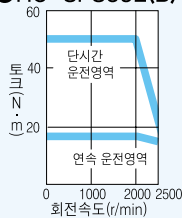

●HC-SFS502(B) (주1)

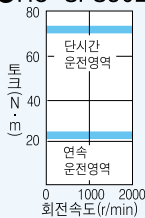

●HC-SFS702(B) (주1)

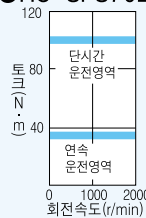

●HC-SFS53(B) (주1, 2)

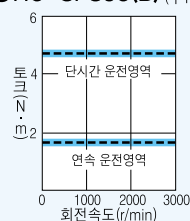

●HC-SFS103(B) (주1)



●HC-SFS153(B) (주1)



●HC-SFS203(B) (주1)



●HC-SFS353(B) (주1)



HC-SFS (400V)

		HC-SFS 2000r/min ()						
HC-SFS		524 (B)	1024 (B)	1524 (B)	2024 (B)	3524 (B)	5024(B)	7024(B)
MR-J2S-		60A4/B4	100A4/B4	200A4/B4		350A4/B4	500A4/B4	700A4/B4
(1)	(kVA)	1.0	1.7	2.5	3.5	5.5	7.5	10.0
	(kW)	0.5	1.0	1.5	2.0	3.5	5.0	7.0
	(N·m)	2.39	4.78	7.16	9.55	16.7	23.9	33.4
	(N·m)	7.16	14.4	21.6	28.5	50.1	71.6	100
(r/min)		2000						
(r/min)		3000			2500		2000	
(r/min)		3450			2875		2300	
(kW/s)		8.7	16.7	25.6	21.5	34.1	56.5	69.7
(A)		1.5	2.8	4.4	5.4	8.6	14	17
(A)		4.5	8.4	13.2	16.2	25.8	42	51
(2, 3) (/)		56	54	136	64	31	39	32
() B	J (× 10 ⁻⁴ kg · m ²)	6.6(8.6)	13.7(15.7)	20.0(22.0)	42.5(52.5)	82.0(92.0)	101(111)	160(170)
		15 (4)						
		17 (1 : 131072p/rev)						
		(IP65) (5)						
		0 40 (), : -15 70 ()						
		80%RH (가), : 90%RH (가)						
		(), 가 . 가 . 가						
		1000m						
(6)		X, Y : 24.5m/s ²			X : 24.5m/s ² Y : 49m/s ²		X : 24.5m/s ² Y : 29.4m/s ²	
(kg) () B		5(7)	7(9)	9(11)	12(18)	19(25)	23(29)	32(38)

- 1.
 2. 가1 (/) 2 1/(m+1) (m= /).
 - 가 가 가 (W) .
 - 가
 - 가
 - 가
3. 600W
4.
5. IP44
6. (bracket)

: <http://www.mitsubishi-automation.co.kr>



HC-SFS (400V)

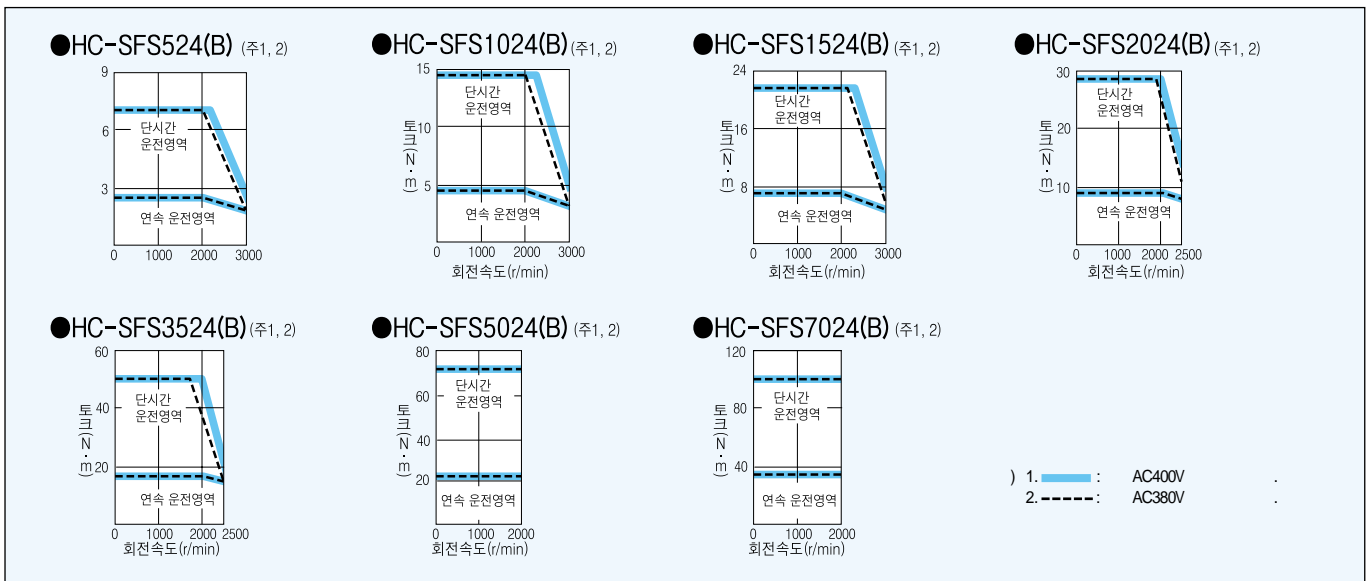

HC-RFS

HC-RFS		HC-RFS ()				
HC-RFS		103(B)	153(B)	203(B)	353(B)	503(B)
(6) MR-J2S-		200A/B/CP/CL		350A/B/CP/CL	500A/B/CP/CL	
(1)	(kVA)	1.7	2.5	3.5	5.5	7.5
	(kW)	1.0	1.5	2.0	3.5	5.0
	(N·m)	3.18	4.78	6.37	11.1	15.9
	(N·m)	7.95	11.9	15.9	27.9	39.7
	(r/min)	3000				
	(r/min)	4500				
	(r/min)	5175				
	(kW/s)	67.4	120	176	150	211
	(A)	6.1	8.8	14	23	28
	(A)	18.4	23.4	37	58	70
(2)	(/)	1090	860	710	174	125
() B	$J (\times 10^{-4} \text{kg} \cdot \text{m}^2)$	1.5(1.85)	1.9(2.25)	2.3(2.65)	8.6(11.8)	12.0(15.5)
		5 (3)				
		17 (1 : 131072p/rev)				
		(IP65)(4)				
		0 40 (), : -15 70 ()				
		80%RH (가), : 90%RH (가)				
		(), 가 . 가 . 가				
	(5)	1000m / X, Y : 24.5m/s ²				
	(kg) () B	3.9(6.0)	5.0(7.0)	6.2(8.3)	12(15)	17(21)

1. 가1
2. 가1 (/) 2 1/(m+1) .(m= /) .
가 가 가 (W) .
: <http://www.mitsubishi-automation.co.kr>
3. IP44
4. (bracket)
5. MR-J2S- CP(1)-S084 MR-J2S- CP(1)



HC-RFS

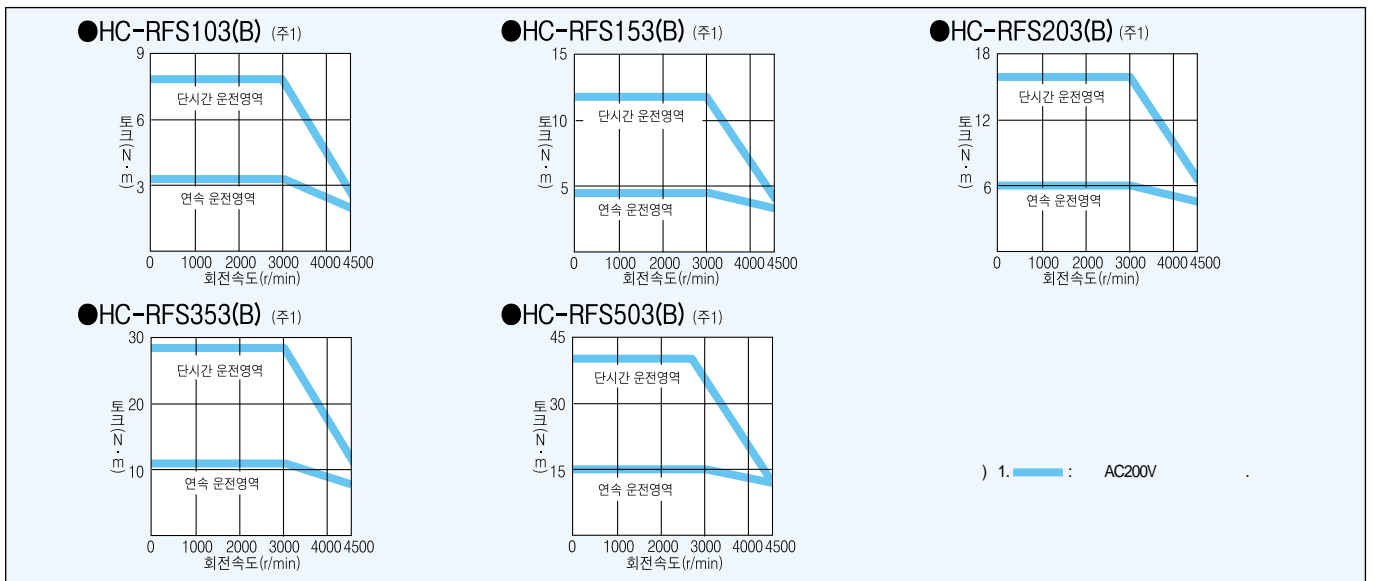

HA-LFS 1000r/min (200V)

		HA-LFS 1000r/min ()							
		601(B)	801(B)	12K1(B)	15K1	20K1	25K1	30K1	37K1(1)
		700A/B/CP/CL (6)	11KA/B		15KA/B	22KA/B		30KA/B	37KA/B
		MR - HP30KA							
(2)	(kVA)	8.6	12	18	22	30	38	48	59
	(kW)	6.0	8.0	12	15	20	25	30	37(75%ED)
(3)	(N·m)	57.3	76.4	115	143	191	239	286	353
	(N·m)	172	229	344	415	477	597	716	883
(4)	(r/min)	1000							
	(r/min)	1200							
	(r/min)	1380							
	(kW/s)	313	265	445	373	561	528	626	668
(5)	(A)	34	42	61	83	118	118	154	188
	(A)	102	126	183	249	295	295	385	470
(6)	(/)	158	354	264	230	195	117	-	-
	(8)	(8)	(8)	(8)	(8)	(8)	(8)	-	-
(7)	J (× 10 ⁻⁴ kg · m ²)	105	220	295	550	650	1080	1310	1870
	(113)	(293)	(369)						
		10 (4)							
		17 (1) : 131072p/rev							
		(IP44)							
		0 40 (), : - 15 70 ()							
		80%RH (가), : 90%RH (가)							
		(), 가 . 가 . 가							
		1000m							
		X : 11.7m/s ² Y : 29.4m/s ²				X : 9.8m/s ² Y : 9.8m/s ²			
(8)	(kg)	55(70)	95(126)	115(146)	160	180	230	250	335
	() B	AC200~220V/50Hz AC200~230V/60Hz							
(9)	(W)	42(50Hz)/54(60Hz)	32(50Hz)/40(60Hz)		45(50Hz)/63(60Hz)			120(50Hz)/175(60Hz)	
	(A)	0.21(50Hz)/0.25(60Hz)	0.30(50Hz)/0.25(60Hz)		0.32(50Hz)/0.35(60Hz)			0.65(50Hz)/0.80(60Hz)	

- 가 37kW 75% 가 . DC (MR - DCL37K)
 -
 - 가1 (/) 2 1/(m+1) .(m= /) .
- 가 가 가 (W)
- : <http://www.mitsubishi-automation.co.kr>

HA-LFS 1000r/min (200V)

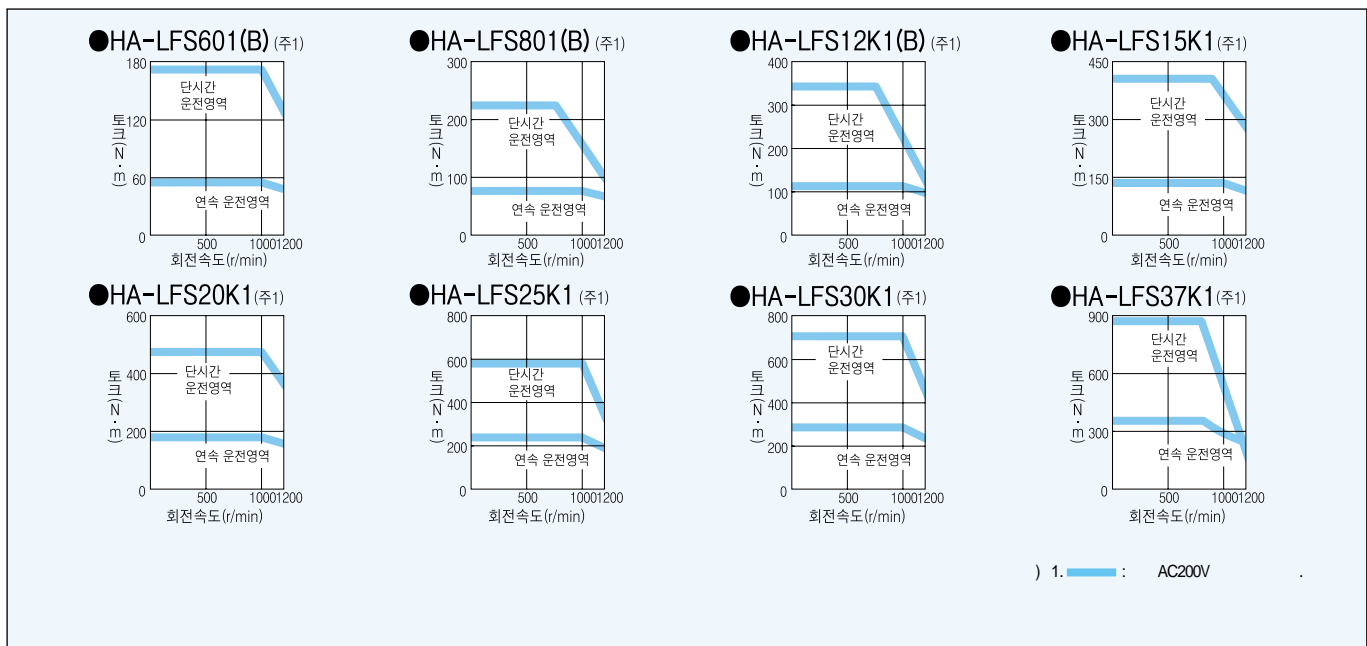

HA-LFS 1000r/min (400V)

HA-LFS 1000r/min ()							
6014(B) () (7) 700A4/B4 - U071 () (7)	8014(B) () (7) 11KA4/B4 - U061 () (7)	12K14(B) () (7) 11KA4/B4 - U062 () (7)	15K14 15KA4/B4 - U063	20K14 () (7) 22KA4/B4 - U064 () (7)	25K14 () (7) 30KA4/B4 - U065 () (7)	30K14 30KA4/B4	37K14 37KA4/B4
MR - HP55KA4							
8.6	12	18	22	30	38	48	59
6.0	8.0	12	15	20	25	30	37
57.3	76.4	115	143	191	239	286	353
172	229	344	415	477	597	716	883
1000							
1200							
1380							
313	265	445	373	561	528	626	668
17	20	30	40	55	70	77	95
51	63	93	126	148	175	193	235
158	354 (8)	264 (8)	230 (8)	195 (8)	-	-	-
105 (113)	220 (293)	295 (369)	550	650	1080	1310	1870
10 (4)							
17 (1 : 131072p/rev)							
IP44							
0 40 () , : - 15 70 ()							
80%RH (가) , : 90%RH (가)							
() , 가 . 가 . 가							
1000m							
X : 11.7m/s ² Y : 29.4m/s ²				X : 9.8m/s ² Y : 9.8m/s ²			
55(70)	95(126)	115(146)	160	180	230	250	335
AC200~220V/50Hz AC200~230V/60Hz		AC380~420V / 50/60Hz		AC380~460V / 50/60Hz			
42(50Hz)/ 54(60Hz)	55(50Hz)/ 75(60Hz)		65(50Hz)/ 85(60Hz)		110(50Hz)/ 150(60Hz)		
0.21(50Hz)/ 0.25(60Hz)	0.12(50Hz)/ 0.11(60Hz)		0.12(50Hz)/ 0.14(60Hz)		0.20(50Hz)/ 0.22(60Hz)		

-
-
-
4. (bracket) 
5. MR - J2S - CP(1) - S084 MR - J2S - CP(1)
7. GRZG400 - No.0(MR - J2S - A) No.2(MR - J2S - B) (1.0m³/min, 92×2)

HA-LFS 1000r/min (400V)

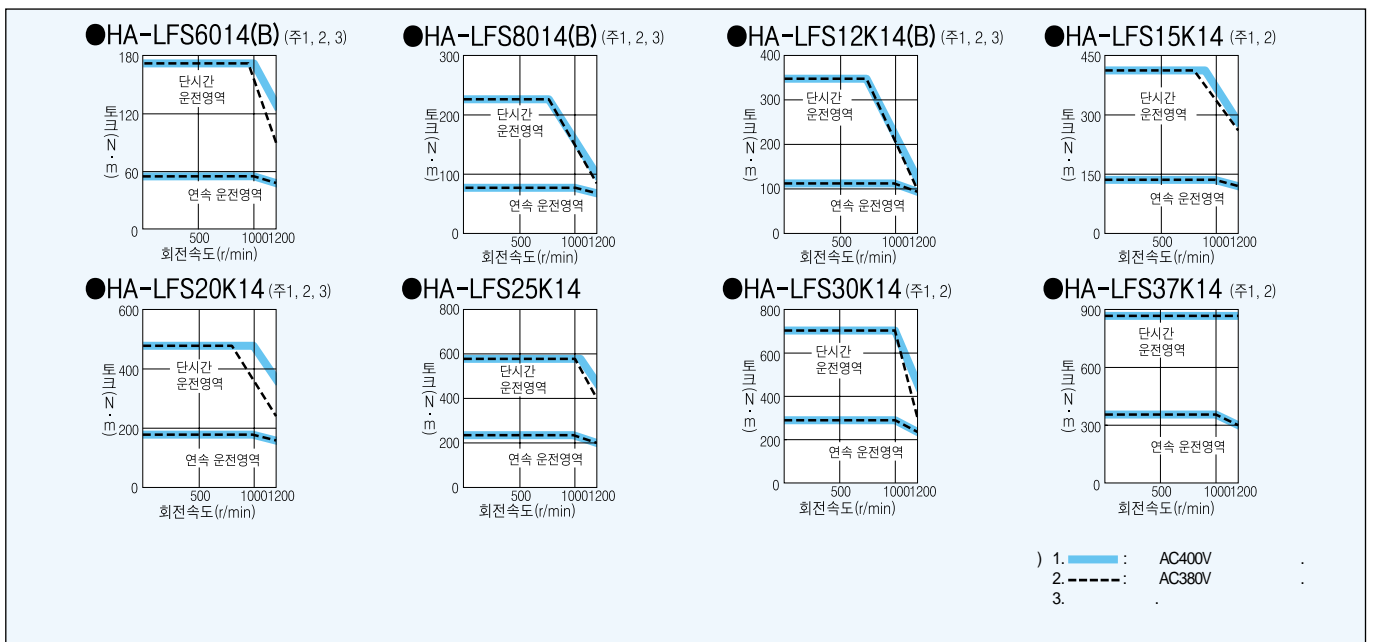

HA-LFS 1500r/min (200V)

		HA-LFS 1500r/min ()					
		701M(B) (700A/B/CP/CL) () (6)	11K1M(B)	15K1M(B)	22K1M	30K1M	37K1M(1)
		MR-J2S-	11KA/B	15KA/B	22KA/B	30KA/B	37KA/B
		MR-HP30KA					
(2)	(kVA)	10	16	22	33	48	59
	(kW)	7.0	11	15	22	30	37(75%ED)
	(N·m)	44.6	70.0	95.5	140	191	236
	(N·m)	134	210	286	350	477	589
	(r/min)	1500					
	(r/min)	2000					
	(r/min)	2300					
	(kW/s)	189	223	309	357	561	514
	(A)	37	65	87	126	174	202
	(A)	111	195	261	315	435	505
(3)	(/)	70	158 (8)	191 (8)	102 (8)	-	-
() B	J (× 10 ⁻⁴ kg·m ²)	105 (113)	220 (293)	295 (369)	550	650	1080
		10 (4)					
		17 (1) : 131072p/rev					
		(IP44)					
		0 40 (), : - 15 70 ()					
		80%RH (가), : 90%RH (가)					
		(), 가 . 가 . 가					
		1000m					
(5)	(kg)	X : 11.7m/s ² Y : 29.4m/s ²			X : 9.8m/s ² Y : 9.8m/s ²		
	() B	55(70)	95(126)	115(146)	160	180	230
		AC200-220V/50Hz		AC200-220V/50Hz			
		AC200-230V/60Hz		AC200-230V/60Hz			
	(W)	42(50Hz)/ 54(60Hz)	32(50Hz)/ 40(60Hz)		45(50Hz)/ 63(60Hz)		120(50Hz)/ 175(60Hz)
	(A)	0.21(50Hz)/ 0.25(60Hz)	0.30(50Hz)/ 0.25(60Hz)		0.32(50Hz)/ 0.35(60Hz)		0.65(50Hz)/ 0.80(60Hz)

- 가 37kW 75% 가 . DC (MR-DCL37K)
-
- 가1 (/) 2 1/(m+1) .(m= /).
가 가 가 (W) .
: <http://www.mitsubishi-automation.co.kr>

HA-LFS 1500r/min (200V)

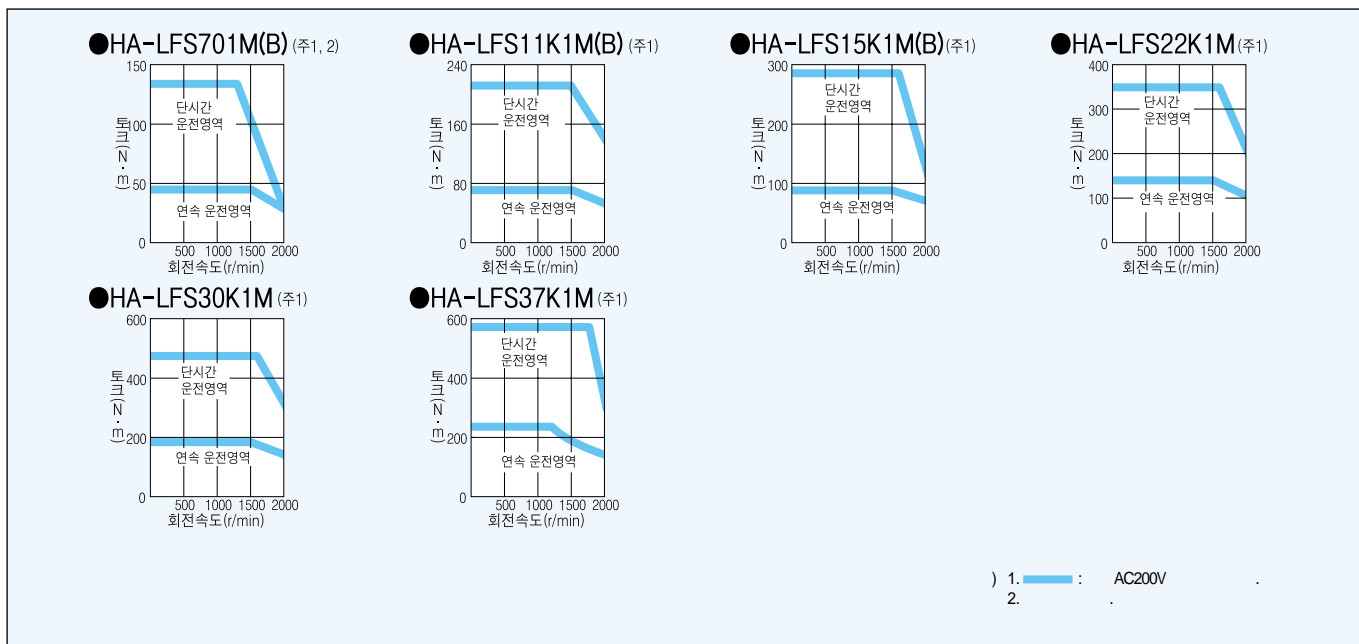

HA-LFS 1500r/min (400V)

HA-LFS 1500r/min ()							
701M4(B) () (7) 700A4/B4 - U073 () (7)	11K1M4(B)	15K1M4(B)	22K1M4	30K1M4	37K1M4	45K1M4	50K1M4
11KA4/B4	15KA4/B4	22KA4/B4	30KA4/B4	37KA4/B4	45KA4/B4	55KA4/B4	
-	-	-	-	MR - HP55KA4			
10	16	22	33	48	59	71	80
7.0	11	15	22	30	37	45	50
44.6	70.0	95.5	140	191	236	286	318
134	210	286	350	477	589	716	796
1500							
2000							
2300							
189	223	309	357	561	514	626	542
18	33	41	63	87	101	128	143
54	99	132	158	218	253	320	358
70	158 (8)	191 (8)	102 (8)	-	-	-	-
105 (113)	220 (293)	295 (369)	550	650	1080	1310	1870
10 (4)							
17 (1) : 131072p/rev							
(IP44)							
0 40 (), : - 15 70 ()							
80%RH (가), : 90%RH (가)							
(), 가 . 가 . 가							
1000m							
X : 11.7m/s ² Y : 29.4m/s ²				X : 9.8m/s ² Y : 9.8m/s ²			
55(70)	95(126)	115(146)	160	180	230	250	335
AC200-220V/50Hz AC200-230V/60Hz	AC380-420V 50/60Hz			AC380-460V 50/60Hz			
42(50Hz)/ 54(60Hz)	55(50Hz)/ 75(60Hz)		65(50Hz)/ 85(60Hz)		110(50Hz)/ 150(60Hz)		
0.21(50Hz)/ 0.25(60Hz)	0.12(50Hz)/ 0.11(60Hz)		0.12(50Hz)/ 0.14(60Hz)		0.20(50Hz)/ 0.22(60Hz)		

-
-
-
4. (bracket)
5. MR - J2S - CP(1) - S084
6. MR - J2S - CP(1)
7. GRZG400 - No.0(MR - J2S - A) No.2(MR - J2S - B) (1.0m³/min, 92×2)



HA-LFS 1500r/min (400V)

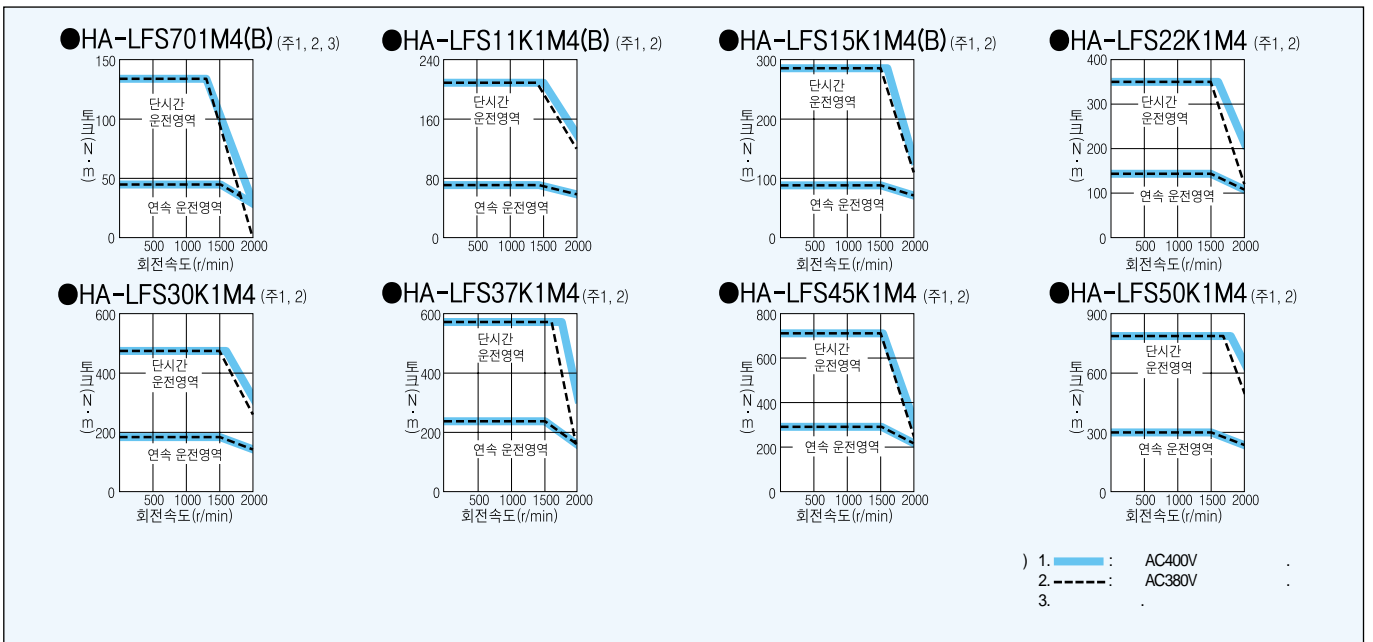

HA - LFS 2000r/min (200V)

		HA - LFS 2000r/min ()						
		502	702	11K2(B)	15K2(B)	22K2(B)	30K2	37K2(1)
		500A/B/CP/CL (6)	700A/B/CP/CL (6)	11KA/B	15KA/B	22KA/B	30KA/B	37KA/B
		-	-	-	-	-	MR - HP30KA	
(2)	(kVA)	7.5	10.0	16	22	33	48	59
	(kW)	5.0	7.0	11	15	22	30	37(75% ED)
	(N · m)	23.9	33.4	52.5	71.6	105	143	177
	(r/min)	71.6	100	158	215	263	358	442
	(r/min)				2000			
	(r/min)				2000			
	(r/min)				2300			
	(kW/s)	77.2	118	263	233	374	373	480
	(A)	25	34	63	77	112	166	204
	(A)	75	102	189	231	280	415	510
(3)	(/)	50	50	186	144	107	-	-
() B	J (× 10 ⁻⁴ kg · m ²)	74.0	94.2	105 (113)	220 (293)	295 (369)	550	650
		10 (4)						
		17 (1) : 131072p/(rev)						
		(IP65) (IP44)						
		0 40 (), : - 15 70 ()						
		80%RH (가), : 90%RH (가)						
		(), 가 . 가 . 가						
		1000m						
(5)	(kg) () B	28	35	55(70)	95(126)	115(146)	160	180
		-	-	AC200~220V/50Hz AC200~230V/60Hz	AC200~220V/50Hz AC200~230V/60Hz			-
	(W)	-	-	42(50Hz)/ 54(60Hz)	32(50Hz)/ 40(60Hz)	45(50Hz)/ 63(60Hz)		-
	(A)	-	-	0.21(50Hz)/ 0.25(60Hz)	0.30(50Hz)/ 0.25(60Hz)	0.32(50Hz)/ 0.35(60Hz)		-

- 가 37kW 75% 가 . DC (MR - DCL37K)
 -
 - 가1 1/(m+1) .(m= /).
- 가 가 가 (W)
- : <http://www.mitsubishi-automation.co.kr>

HA - LFS 2000r/min (200V)

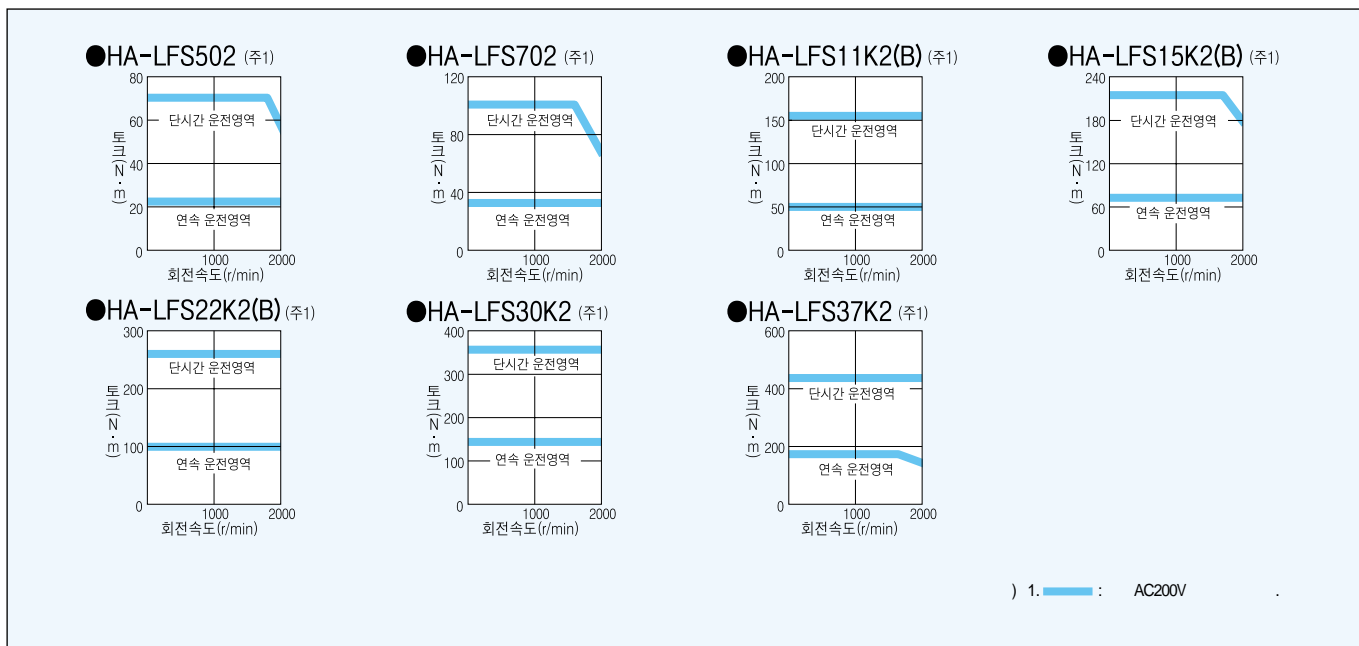

HA - LFS 2000r/min (400V)

HA - LFS 2000r/min ()								
11K24(B)	15K24(B)	22K24(B)	30K24	37K24	45K24	55K24		
11KA4/B4	15KA4/B4	22KA4/B4	30KA4/B4	37KA4/B4	45KA4/B4	55KA4/B4		
-	-	-	MR - HP55KA4					
16	22	33	48	59	71	87		
11	15	22	30	37	45	55		
52.5	71.6	105	143	177	215	263		
158	215	263	358	442	537	657		
			2000					
			2000					
			2300					
263	233	374	373	480	427	526		
32	40	57	83	102	131	143		
96	117	140	208	255	328	358		
186	144	107	-	-	-	-		
(7)	(7)	(7)	-	-	-	-		
105	220	295	550	650	1080	1310		
(113)	(293)	(369)						
			10	(4)				
			17	(1)		: 131072p/rev		
(IP44)								
0 40 (), : - 15 70 ()								
80%RH (가), : 90%RH (가)								
(), 가 . 가 . 가								
1000m								
X : 11.7m/s ² Y : 29.4m/s ²				X : 9.8m/s ² Y : 9.8m/s ²				
55(70)	95(126)	115(146)	160	180	230	250		
AC200-220V/50Hz	AC380-420V 50/60Hz			AC380-460V 50/60Hz				
AC200-230V/60Hz								
42(50Hz)/	55(50Hz)/		65(50Hz)/		110(50Hz)/			
54(60Hz)	75(60Hz)		85(60Hz)		150(60Hz)			
0.21(50Hz)/	0.12(50Hz)/		0.12(50Hz)/		0.20(50Hz)/			
0.25(60Hz)	0.11(60Hz)		0.14(60Hz)		0.22(60Hz)			

4. (bracket)
5. ()
6. MR - J2S - CP(1) - S084 MR - J2S - CP(1) No.0(MR - J2S - A) No.2(MR - J2S - B) (1.0m³/min, 92×2)
7. GRZG400 - No.0(MR - J2S - A) No.2(MR - J2S - B) (1.0m³/min, 92×2)

HA - LFS 2000r/min (400V)

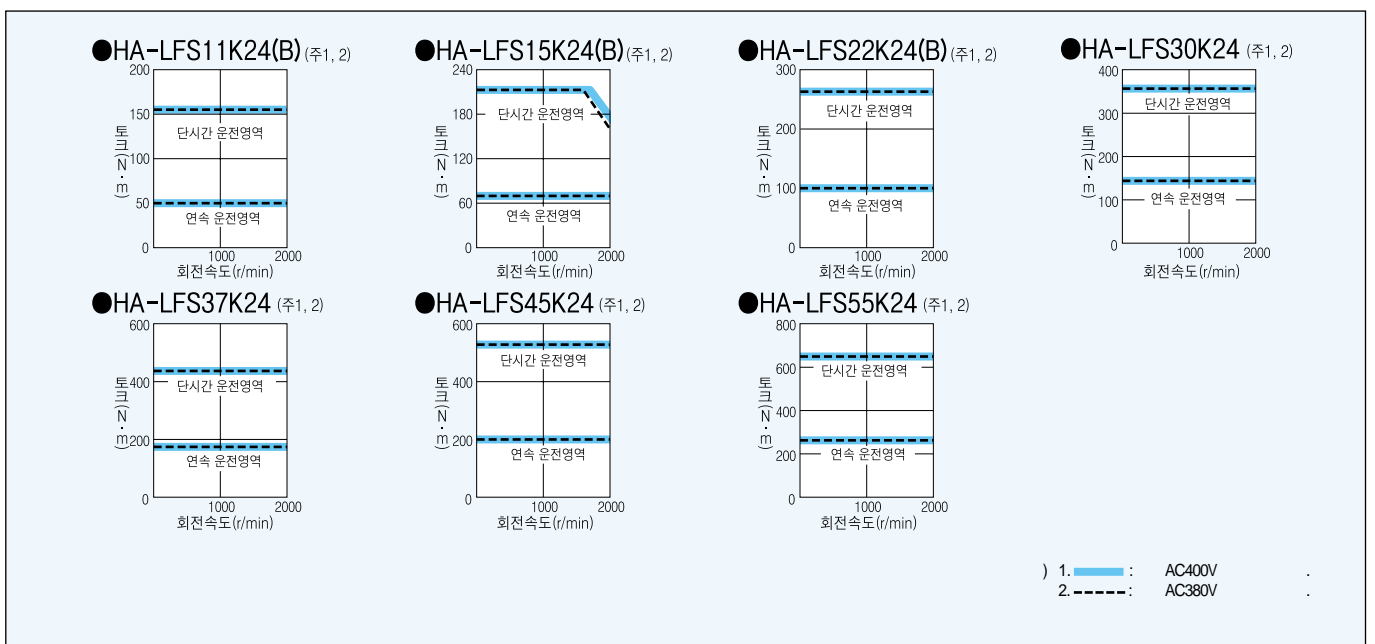

HC-UFS

		HC-UFS 2000r/min ()					HC-UFS 3000r/min ()				
HC-UFS		72(B)	152(B)	202(B)	352(B)	502(B)	13(B)	23(B)	43(B)	73(B)	
MR-J2S-		70A/B/CP/CL	200A/B/CP/CL	350A/B/CP/CL	500A/B/CP/CL		10A(1)/B(1)/CP(1)/CL(1)	20A(1)/B(1)/CP(1)/CL(1)	40A(1)/B(1)/CP(1)/CL(1)	70A/B/CP/CL	
(8)											
(1)	(kVA)	1.3	2.5	3.5	5.5	7.5	0.3	0.5	0.9	1.3	
	(kW)	0.75	1.5	2.0	3.5	5.0	0.1	0.2	0.4	0.75	
	(N·m)	3.58	7.16	9.55	16.7	23.9	0.32	0.64	1.3	2.4	
	(N·m)	10.7	21.6	28.5	50.1	71.6	0.95	1.9	3.8	7.2	
	(r/min)	2000					3000				
	(r/min)	3000			2500		4500				
	(r/min)	3450			2875		5175				
	(kW/s)	12.3	23.2	23.9	36.5	49.6	15.5	19.2	47.7	9.76	
	(A)	5.4	9.7	14	23	28	0.76	1.5	2.8	4.3	
	(A)	16.2	29.1	42	69	84	2.5	4.95	9.24	12.9	
(2, 3)	(/)	53	124	68	44	31	(4)	(4)	410	41	
() B	J (× 10 ⁻⁴ kg·m ²)	10.4 (12.4)	22.1 (24.1)	38.2 (46.8)	76.5 (85.1)	115 (123.6)	0.066 (0.074)	0.241 (0.323)	0.365 (0.447)	5.90 (6.10)	
		15 (5)									
		17 (1 : 131072p/rev)									
		(IP65)					(IP65) (6)				
		0 40 (), : -15 70 ()									
		80%RH (가), : 90%RH (가)									
		(), 가 . 가 . 가									
		1000m									
	(7)	X, Y : 24.5m/s ²			X : 24.5m/s ² Y : 49m/s ²		X, Y : 49m/s ²				
	(kg)	() B	8(10)	11(13)	16(22)	20(26)	24(30)	0.8(1.2)	1.5(2.2)	1.7(2.4)	5.0(6.2)

1. 가1
2. 가1 (/ 가) 2 1/(m+1) (m= /).

가 가 가 (W) .

: <http://www.mitsubishi-automation.co.kr>

3. 600W

4. 가

5. 15 가

6. IP65 (HC-UFS -S1)

7. (bracket)

8. MR-J2S- CP(1) - S084

MR-J2S- CP(1)



HC-UFS

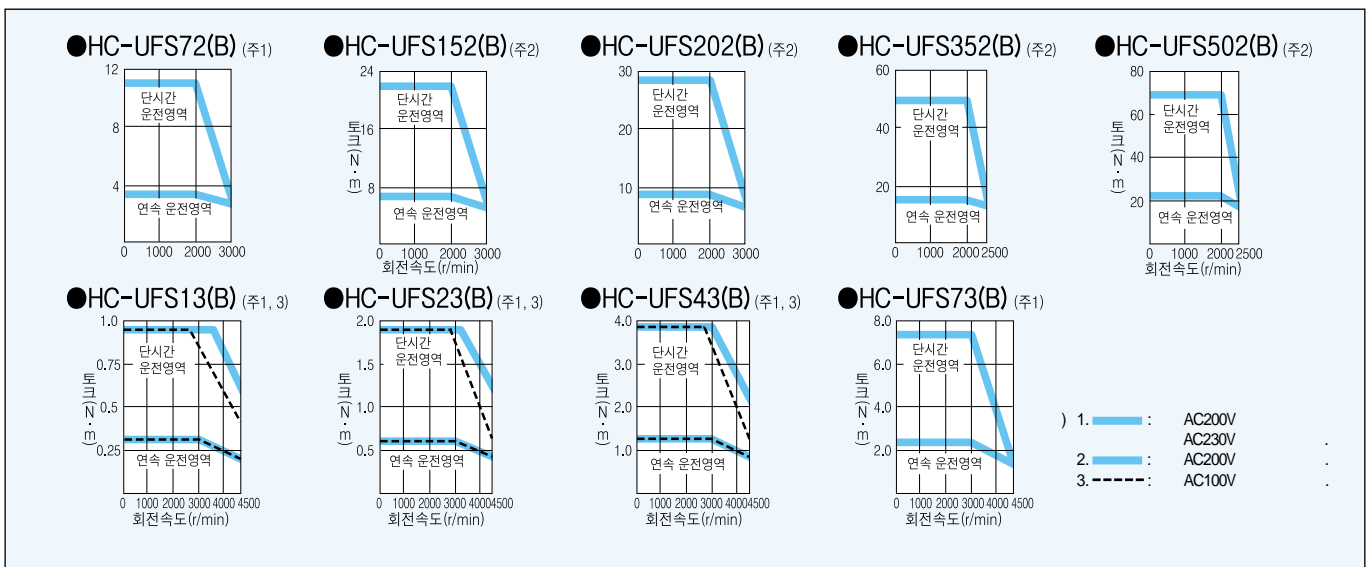

()

A
B
C
D
E

<HC-KFS, MFS, UFS 3000r/min >

[key] ... 200, 400, 750W

	(W)	T	S	R	Q	W	QK	QL	U	Y
		HC-KFS K (4)	200 400	5	14h6	30	27	5	20	3
HC-MFS K	750	6	19h6	40	37	6	25	5	3.5	M5 20
HC-UFS K	200 400	5	14h6	30	23.5	5	20	3	3	M4 15
	750	6	19h6	40	32.5	6	25	5	3.5	M5 20

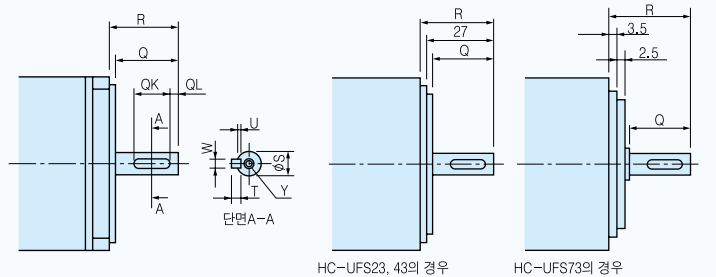

HC-UFS23, 43의 경우 HC-UFS73의 경우

(: mm)

(1)

D- ... 50, 100W

	(W)	R	QK
		HC-KFS D HC-MFS D	50, 100
HC-UFS D	100	25	17.5

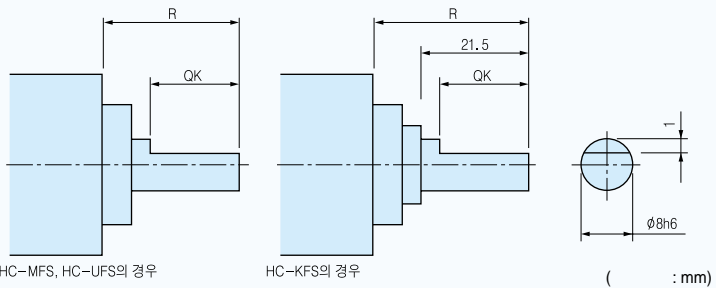

HC-MFS, HC-UFS의 경우

HC-KFS의 경우

(: mm)

(1)

<HC-SFS, LFS, RFS, UFS 2000r/min, HA-LFS >

[key]

	(kW)	S	R	Q	W	QK	QL	U	r	Y
		HC-SFS K HC-LFS K (3)	0.5~1.5 2.0~7.0	24h6 $35^{+0.01}_0$	55 79	50 75	$8^{0}_{-0.036}$ $10^{0}_{-0.036}$	36 55	5 5	$4^{+0.2}_0$ $5^{+0.2}_0$
HC-RFS K	1.0, 1.5, 2.0 3.5, 5.0	24h6 28h6	45 63	40 58	$8^{0}_{-0.036}$ $8^{0}_{-0.036}$	25 45	5 5	$4^{+0.2}_0$ $4^{+0.2}_0$	4 4	M8 20
	HC-UFS K	0.75 1.5 2.0, 3.5, 5.0	22h6 28h6 $35^{+0.01}_0$	55 55 65	50 50 60	$6^{0}_{-0.036}$ $8^{0}_{-0.036}$ $10^{0}_{-0.036}$	42 45 50	3 5 5	$3.5^{+0.1}_0$ $4^{+0.2}_0$ $5^{+0.2}_0$	3 4 5

(1, 2)

	(HA-LFS K)	S	R	Q	W	QK	QL	U	r	Y
		601, 6014 () 701M (), 701M4 (), 502, 702, 11K2, 11K24	42h6	85	80	$12^{0}_{-0.04}$	70	5	$5^{+0.2}_0$	6
801, 12K1, 8014 (), 12K14 () 11K1M, 15K1M, 11K1M4, 15K1M4, 15K2, 22K2, 15K24, 22K24	55m6	110	110	$16^{0}_{-0.04}$	90	5	$6^{+0.2}_0$	8		
15K1, 20K1, 15K14, 20K14 () 22K1M, 30K1M, 22K1M4, 30K1M4, 30K2, 37K2, 30K24, 37K24	60m6	140	140	$18^{0}_{-0.04}$	128	6	$7^{+0.2}_0$	9		
25K1, 30K1, 25K14 (), 30K14 37K1M, 37K1M4, 45K1M4 45K24, 55K24	65m6	140	140	$18^{0}_{-0.04}$	128	6	$7^{+0.2}_0$	9		
37K1, 37K14, 50K1M4	80m6	170	170	$22^{0}_{-0.04}$	147	11	$9^{+0.2}_0$	11		

(1, 2)

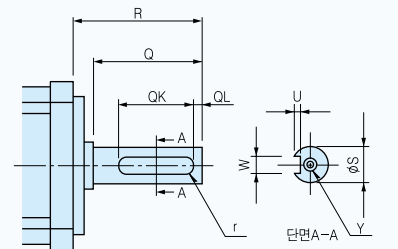

그림A

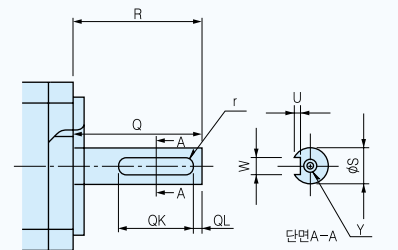

그림B

(: mm)

1.
2.
3. HC-SFS121 2.0~7.0KW
4. HC-KFS46 HC-KFS410 가 HC-KFS23K HC-KFS43K

HC - KFS G1 HC - MFS G1()

가

HC - G7()

(HC - G7K)

가

<HC - KFS, MFS, SFS, RFS >

[key]

		S	Q	W	QK	U	T	Y
HC - KFS053G7K HC - MFS053G7K	1/5	16	28	5	25	3	5	M4 8
	1/11							
	1/21							
	1/33							
	1/45							
HC - KFS13G7K HC - MFS13G7K	1/5	25	42	8	36	4	7	M6 12
	1/11							
	1/21							
	1/33							
	1/45							
HC - KFS23G7K HC - MFS23G7K	1/5	16	28	5	25	3	5	M4 8
	1/11							
	1/21							
	1/33							
	1/45							
HC - KFS43G7K HC - MFS43G7K	1/5	16	28	5	25	3	5	M4 8
	1/11							
	1/21							
	1/33							
	1/45							
HC - KFS73G7K HC - MFS73G7K	1/5	25	42	8	36	4	7	M6 12
	1/11							
	1/21							
	1/33							
	1/45							

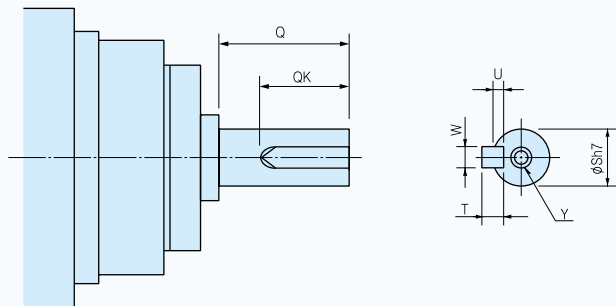

		S	Q	W	QK	U	T	Y
HC - SFS52(4)G7K	1/5	25	42	8	36	4	7	M6 12
	1/11							
	1/21							
	1/33							
	1/45							
HC - SFS102(4)G7K	1/5	25	42	8	36	4	7	M6 12
	1/11							
	1/21							
	1/33							
	1/45							
HC - SFS152(4)G7K	1/5	40	82	12	70	5	8	M10 20
	1/11							
	1/21							
	1/33							
	1/45							
HC - SFS202(4)G7K	1/5	40	82	12	70	5	8	M10 20
	1/11							
	1/21							
	1/33							
	1/45							
HC - SFS352(4)G7K	1/5	40	82	12	70	5	8	M10 20
	1/11							
	1/21							
	1/33							
	1/45							
HC - SFS502(4)G7K	1/5	50	82	14	70	5.5	9	M10 20
	1/11							
	1/21							
HC - SFS702(4)G7K	1/5	50	82	14	70	5.5	9	M10 20
	1/11							

		S	Q	W	QK	U	T	Y
HC - RFS103G7K	1/5	25	42	8	36	4	7	M6 12
	1/11							
	1/21							
	1/33							
	1/45							
HC - RFS153G7K	1/5	25	42	8	36	4	7	M6 12
	1/11							
	1/21							
	1/33							
	1/45							
HC - RFS203G7K	1/5	40	82	12	70	5	8	M10 20
	1/11							
	1/21							
	1/33							
	1/45							
HC - RFS353G7K	1/5	40	82	12	70	5	8	M10 20
	1/11							
	1/21							
	1/33							
	1/45							
HC - RFS503G7K	1/5	50	82	14	70	5.5	9	M10 20
	1/11							
	1/21							

) 1.

2.

3.

G7

(G7)

		HC - KFS, MFS					HC - SFS 1000 r/min			
		053B	13B	23B	43B	73B	81B	121B	201B	301B
		DC24V $\frac{0}{.10}$ %					DC24V $\frac{0}{.10}$ %			
(N · m)		0.32	0.32	1.3	1.3	2.4	8.3	43.1	43.1	43.1
(W)at 20		6.3	6.3	7.9	7.9	9	19	34	34	34
(J)/		5.6	5.6	22	22	64	400	4500	4500	4500
(J)/Hr		56	56	220	220	640	4000	45000	45000	45000
(1)	(1)	2 (4J)	2 (4J)	2 (15J)	2 (15J)	2 (32J)	2 (200J)	2 (1000J)	2 (1000J)	2 (1000J)

		HC - SFS 2000 r/min												
		52B	102B	152B	202B	352B	502B	702B	524B	1024B	1524B	2024B	3524B	5024B
		DC24V $\frac{0}{.10}$ %												
(N · m)		8.3	8.3	8.3	43.1	43.1	43.1	8.3	8.3	8.3	43.1	43.1	43.1	43.1
(W)at 20		19	19	19	34	34	34	19	19	19	34	34	34	34
(J)/		400	400	400	4500	4500	4500	400	400	400	4500	4500	4500	4500
(J)/Hr		4000	4000	4000	45000	45000	45000	4000	4000	4000	45000	45000	45000	45000
(1)	(1)	2 (200J)	2 (200J)	2 (200J)	2 (1000J)	2 (1000J)	2 (1000J)	2 (200J)	2 (200J)	2 (200J)	2 (1000J)	2 (1000J)	2 (1000J)	2 (1000J)

		HC - SFS 3000 r/min					HC - LFS					HC - RFS				
		53B	103B	153B	203B	353B	52B	102B	152B	202B	302B	103B	153B	203B	353B	503B
		DC24V $\frac{0}{.10}$ %					DC24V $\frac{0}{.10}$ %					DC24V $\frac{0}{.10}$ %				
(N · m)		8.3	8.3	8.3	43.1	43.1	8.3	8.3	8.3	43.1	43.1	6.8	6.8	6.8	16.7	16.7
(W)at 20		19	19	19	34	34	19	19	19	34	34	19	19	19	23	23
(J)/		400	400	400	4500	4500	400	400	400	4500	4500	400	400	400	400	400
(J)/Hr		4000	4000	4000	45000	45000	4000	4000	4000	45000	45000	4000	4000	4000	4000	4000
(1)	(1)	2 (200J)	2 (200J)	2 (200J)	2 (1000J)	2 (1000J)	2 (200J)	2 (200J)	2 (200J)	2 (1000J)	2 (1000J)	2 (200J)	2 (200J)	2 (200J)	2 (200J)	2 (200J)

		HA - LFS 1000 r/min						HA - LFS 1500 r/min					
		601B	801B	12K1B	6014B	8014B	12K14B	701MB	11K1MB	15K1MB	701M4B	11K1M4B	15K1M4B
		DC24V $\frac{0}{.10}$ %						DC24V $\frac{0}{.10}$ %					
(N · m)		82	160.5	160.5	82	160.5	160.5	82	160.5	160.5	82	160.5	160.5
(W)at 20		30	46	46	30	46	46	30	46	46	30	46	46
(J)/		3000	5000	5000	3000	5000	5000	3000	5000	5000	3000	5000	5000
(J)/Hr		30000	50000	50000	30000	50000	50000	30000	50000	50000	30000	50000	50000
(1)	(1)	2 (1000J)	2 (3000J)	2 (3000J)	2 (1000J)	2 (3000J)	2 (3000J)	2 (1000J)	2 (3000J)	2 (3000J)	2 (1000J)	2 (3000J)	2 (3000J)

		HA - LFS 2000 r/min						HC - UFS 2000 r/min				HC - UFS 3000 r/min				
		11K2B	15K2B	22K2B	11K24B	15K24B	22K24B	72B	152B	202B	352B	502B	13B	23B	43B	73B
		DC24V $\frac{0}{.10}$ %						DC24V $\frac{0}{.10}$ %				DC24V $\frac{0}{.10}$ %				
(N · m)		82	160.5	160.5	82	160.5	160.5	8.3	8.3	43.1	43.1	43.1	0.32	1.3	1.3	2.4
(W)at 20		30	46	46	30	46	46	19	19	34	34	34	6.3	7.9	7.9	10
(J)/		3000	5000	5000	3000	5000	5000	400	400	4500	4500	4500	5.6	22	22	64
(J)/Hr		30000	50000	50000	30000	50000	50000	4000	4000	45000	45000	45000	56	220	220	640
(1)	(1)	2 (1000J)	2 (3000J)	2 (3000J)	2 (1000J)	2 (3000J)	2 (3000J)	2 (200J)	2 (200J)	2 (1000J)	2 (1000J)	2 (1000J)	2 (4J)	2 (15J)	2 (15J)	2 (32J)

) 1.
2.

< (G1)>

(W)	HC - KFS, HC - MFS (3)			HC - SFS2000r/min (4)						
	1/5	1/12	1/20	1/6	1/11	1/17	1/29	1/35	1/43	1/59
50	(9/44)	(49/576)	(25/484)	-	-	-	-	-	-	-
100	(9/44)	(49/576)	(25/484)	-	-	-	-	-	-	-
200	(19/96)	(25/288)	(253/5000)	-	-	-	-	-	-	-
400	(19/96)	(25/288)	(253/5000)	-	-	-	-	-	-	-
500	-	-	-	-	-	-	-	-	-	-
750	-	(525/6048)	(625/12544)	-	-	-	-	-	-	-
1000	-	-	-	-	-	-	-	-	-	-
1500	-	-	-	-	-	-	(2)	(2)	(2)	(2)
2000	-	-	-	-	-	-	(2)	(2)	(2)	(2)
3500	-	-	-	(2)	(2)	(2)	(2)	(2)	(2)	(2)
5000	-	-	-	-	(2)	(2)	(2)	(2)	(2)	-
7000	-	-	-	-	(2)	(2)	(2)	(2)	(2)	-

- 가 (2) 가 , 가 가
- (2) 가 , 가 가
- ()
- HC - SFS2000r/min G1() G1H()

	HC - KFS	HC - MFS	HC - SFS 2000r/min
(1)	45 75%	45 75%	85 94%
	()	()	()
	가	가	가
	60	60	40 2, (2)
(3)	5	25	4
()	4500r/min	4500r/min	2000r/min

- 1.
- 2.
- 3.

< (G2)>

(W)	HC - KFS, HC - MFS				HC - SFS2000r/min					HC - RFS				
	1/5	1/9	1/20	1/29	1/5	1/9	1/20	1/29	1/45	1/5	1/9	1/20	1/29	1/45
50					-	-	-	-	-	-	-	-	-	-
100					-	-	-	-	-	-	-	-	-	-
200					-	-	-	-	-	-	-	-	-	-
400					-	-	-	-	-	-	-	-	-	-
500	-	-	-	-	-	-	-	-	-	-	-	-	-	-
750	-	-	-	-	-	-	-	-	-	-	-	-	-	-
1000	-	-	-	-	-	-	-	-	-	-	-	-	-	-
1500	-	-	-	-	-	-	-	-	-	-	-	-	-	-
2000	-	-	-	-	-	-	-	-	-	-	-	-	-	-
3500	-	-	-	-	-	-	-	-	-	-	-	-	-	-
5000	-	-	-	-	-	-	-	-	-	-	-	-	-	-
7000	-	-	-	-	-	-	-	-	-	-	-	-	-	-

1. 가 가

	HC - KFS	HC - MFS	HC - SFS2000r/min	HC - RFS
(1)	60 80%	60 80%	80 90%	80 90%
	()	()	()	()
	가	가	가	가
	3	3	3	3
(3)	50, 100, 750W : 5 200, 400W : 7	25	5	5
()	4500r/min	4500r/min	0.5~1.5kW : 3000r/min 2~3.5kW : 2500r/min 5~7kW : 2000r/min	4000r/min

- 1.
- 2.

<
<

(G5)>
(G7)>

(W)	HC - KFS, HC - MFS					HC - SFS2000r/min					HC - RFS				
	1/5	1/11	1/21	1/33	1/45	1/5	1/11	1/21	1/33	1/45	1/5	1/11	1/21	1/33	1/45
50						-	-	-	-	-	-	-	-	-	-
100						-	-	-	-	-	-	-	-	-	-
200						-	-	-	-	-	-	-	-	-	-
400						-	-	-	-	-	-	-	-	-	-
500	-	-	-	-	-										
750						-	-	-	-	-	-	-	-	-	-
1000	-	-	-	-	-										
1500	-	-	-	-	-										
2000	-	-	-	-	-										
3500	-	-	-	-	-				-	-					-
5000	-	-	-	-	-				-	-				-	-
7000	-	-	-	-	-	-	-	-	-	-	-	-	-	-	-

) 1. 가 . 가 .

	HC - KFS	HC - MFS	HC - SFS2000r/min	HC - RFS
(1)	58~87%(2)	58~87%(2)	77~92%	71 90%
	()	()	()	()
	가	가	가	가
	3	3	3	3
(3)	50, 100, 750W : 10 200, 400W : 14	25	10	5
()	4500r/min	4500r/min	0.5~1.5kW : 3000r/min 2, 3.5kW : 2500r/min 5, 7kW : 2000r/min	4500r/min

) 1.
2. HC - KFS053, HC - MFS - 053 22~41%
3.

MR-J2S-700A(4)/CP/CL

(MR-J2S-A, CP, CL)

- QD75P
- QD75D
- AD75P
- A1SD75P
- FX2N - 20GM
- FX2N - 10GM
- FX2N - 10PG
- FX2N - 1PG

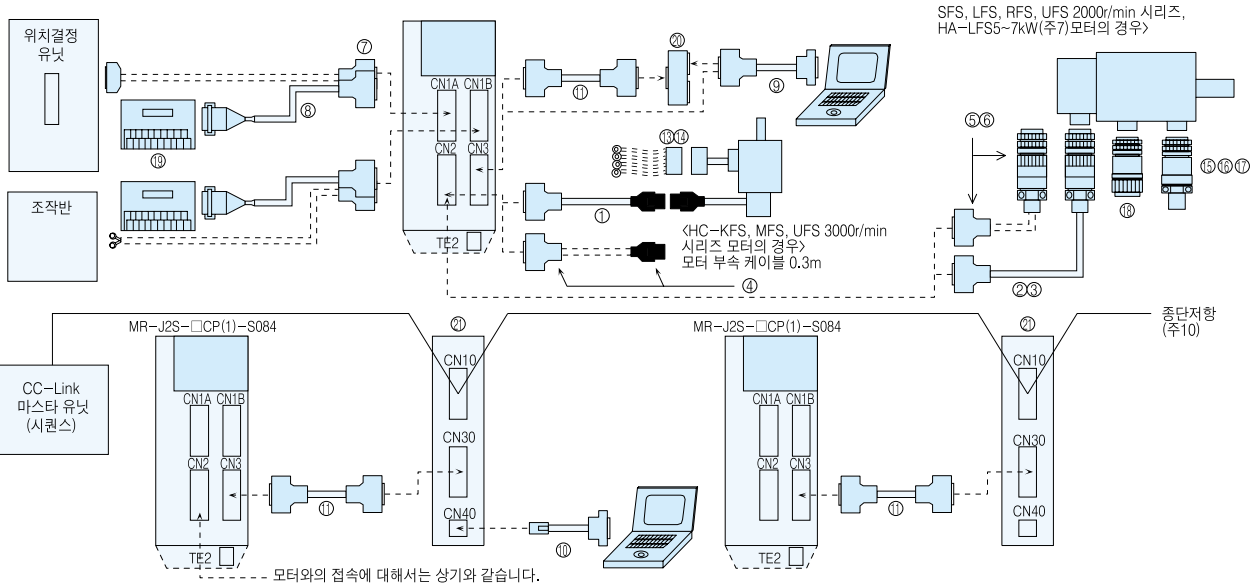

가	CN2	Motor Type	Cable Length	IP Rating	Cable Part Numbers	
					3M	AMP / DDK
가	CN2	<HC - KFS, MFS, UFS3000r/min >	MR - JCCBL M - H : (1) 2, 5, 10, 20, 30, 50m	IP20	10120 - 3000VE () 10320 - 52F0 - 008 () (3)	1 - 172161 - 9 (AMP) 170359 - 1 () MTI - 0002 ()
			MR - JCCBL M - L : (1) 2, 5, 10, 20, 30m	IP20		
	CN2	<HC - SFS, LFS, RFS UFS2000r/min, HA - LFS >	MR - JHSCBL M - H : (1) 2, 5, 10, 20, 30, 50m	IP20	10120 - 3000VE () 10320 - 52F0 - 008 () (3)	MS3057 - 12A () MS3106B20 - 29S ()
			MR - JHSCBL M - L : (1) 2, 5, 10, 20, 30m	IP20		
	CN2	(4)	MR - ENCBL M - H : (1, 6) 2, 5, 10, 20, 30, 50m	IP65 IP67		(DDK) CE02 - 20BS - S (DDK) MS3106A20 - 29S (D190) CE3057 - 12A - 3 (D265)
가	CN1	<HC - KFS, MFS, UFS3000r/min >	MR - J2CNM	IP20	10120 - 3000VE () 10320 - 52F0 - 008 () (3)	1 - 172161 - 9 (AMP) 170359 - 1 () MTI - 0002 () (2)
		<HC - SFS, LFS, RFS UFS2000r/min, HA - LFS >	MR - J2CNS	IP20	10120 - 3000VE () 10320 - 52F0 - 008 () (3)	MS3057 - 12A () MS3106B20 - 29S ()
			MR - ENCNS	IP65 IP67	(DDK) MS3106A20 - 29S (D190) 10120 - 3000VE () 10320 - 52F0 - 008 () (3)	(DDK) CE02 - 20BS - S (DDK) CE3057 - 12A - 3 (D265)
가	CN1A, CN1B	MR - J2CN1 (5)	-		10120 - 3000VE () 10320 - 52F0 - 008 () (3)	
		MR - J2TBL M : 0.5, 1m	-		HIF3BA - 20D - 2.54R ()	10120 - 3000VE () 10320 - 52F0 - 008 () (3)

1. -H, -L
2. AMP 172161-1 ()
3. 170363-1 () 가
4. MR-JHSCBL M-H, -L IP65
5. RS-422 MR-J2CN1
- 6.
7. HA-LFS601, 6014, 701M, 701M4
8. CC-Link 0.5m
9. CN10 CC-Link CN10
10. CC-Link

MR-J2S-11KA(4)~MR-J2S-22KA(4)

(MR-J2S-A)

- QD75P
- QD75D
- AD75P
- A1SD75P
- FX2N-20GM
- FX2N-10GM
- FX2N-10PG
- FX2N-1PG

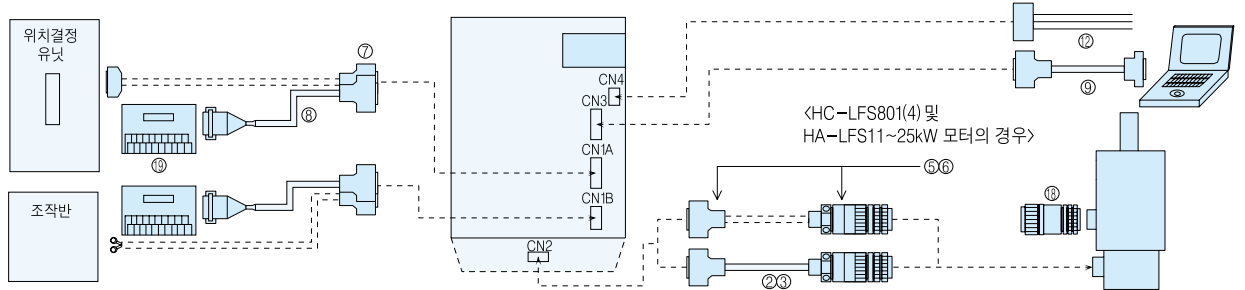

C N 3		MR - CPCATCBL3M 3m	-	RS-232C (3M)) 10120-3000VE ()) 10320-52F0-008 () (3)	DOS/V ()) DE-9SF-N()) DE-C1-J6-S6())	
		MR - JRPCATCBL3M 3m	-	5557-04R-210((molex)) 5556())	DOS/V ()) DE-9SF-N()) DE-C1-J6-S6())	
	- CC - Link	MR - J2HBUS M : 0.5, 1, 5m (8)	-	10120-3000VE ((3M))) 10320-52F0-008 () (3)	10120-3000VE ((3M))) 10320-52F0-008 () (3)	
C N 4	CN4	MR - H3CBL1M 1m	-	171822-4 ((AMP)))) 11kW	
가	HC - KFS, MFS, UFS3000r/min	MR - PWCNK1	IP20	5559-04P-210 (molex)) 5558PBT3L (molex) (AWG16))		
	HC - KFS, MFS, UFS3000r/min	MR - PWCNK2	IP20	5559-06P-210 (molex)) 5558PBT3L (molex) (AWG16))		
	HC - SFS81 HC - SFS52, 102, 152, 524, 1024, 1524 HC - SFS53, 103, 153 HC - LFS52, 102, 152 HC - RFS103, 153, 203 HC - UFS72, 152	MR - PWCNS1 ())	IP65 IP67	CE05-6A24-10SD-B-BSS (DDK)) CE3057-16A-1 (D265) (DDK)		
	HC - SFS121, 201, 301 HC - SFS202, 352, 502, 2024, 3524, 5024 HC - SFS203, 353 HC - LFS202, 302 HC - RFS353, 503 HA - LFS502 HC - UFS202, 352, 502	MR - PWCNS2 ())	IP65 IP67	CE05-6A24-10SD-B-BSS (DDK)) CE3057-16A-2 (D265) (DDK)		
	HC - SFS702, 7024 HA - LFS702	MR - PWCNS3 ())	IP65 IP67	CE05-6A32-17SD-B-BSS (DDK)) CE3057-20A-1 (D265) (DDK)		
	HC - SFS121B, 201B, 301B HC - SFS202B, 352B, 502B, 702B, 2024B, 3524B, 5024B, 7024B HC - SFS203B, 353B HC - LFS202B, 302B HA - LFS601B, 801B, 12K1B, 6014B, 8014B, 12K14B HA - LFS701MB, 11K1MB, 15K1MB, 701M4B, 11K1M4B, 15K1M4B HA - LFS11K2B, 15K2B, 22K2B, 11K24B, 15K24B, 22K24B HC - UFS202B, 352B, 502B	MR - BKCNCN ())	IP65 IP67	MS3106A10SL-4S(D190) (DDK)) YS010-5-8 () ())		
		MR - TB20	-			
		MR - J2CN3TM	-) 11kW	
	CC - Link	MR - J2S - T01	-	MR - J2S - CP (1) - S084		





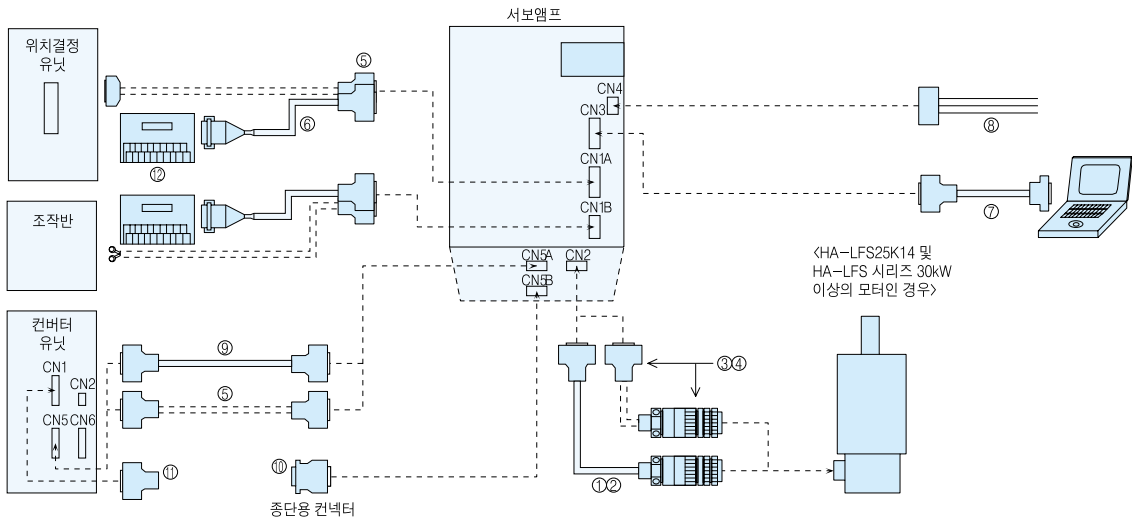

MELSERVO J2 Super

MR-J2S-30KA(4)





(MR-J2S-A)

- QD75P
- QD75D
- AD75P
- A1SD75P
- FX2N - 20GM
- FX2N - 10GM
- FX2N - 10PG
- FX2N - 1PG

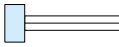

가		C N 2	MR - JHSCBL M - H	IP20	10120 - 3000VE () (3M) 10320 - 52FO - 008 () (2)	MS3057 - 12A () MS3106B20 - 29S ()
			: 2, 5, 10, 20, 30, 50m (1)			
	<HA - LFS >	(3)	MR - JHSCBL M - L	IP20		
			: 2, 5, 10, 20, 30m (1)			
			MR - ENCBL M - H	IP65 IP67		
: 2, 5, 10, 20, 30, 50m (1, 5)						
MR - J2CNS	IP20		(3M) 10120 - 3000VE () 10320 - 52FO - 008 () (2)	MS3057 - 12A () MS3106B20 - 29S ()		
<HA - LFS >						
MR - ENCNS	IP65 IP67					(DDK) MS3106A20 - 29S (D190) () (DDK) CE02 - 20BS - S (DDK) CE3057 - 12A - 3 (D265)
(4)						
: 0.5, 1m						
		C N 1	MR - J2CN1	-		(3M) 10120 - 3000VE () 10320 - 52FO - 008 () (2)
		C N 1 B,	MR - J2TBL M	-		() HIF3BA - 20D - 2.54R () (3M) 10120 - 3000VE () 10320 - 52FO - 008 () (2)

1. -H, -L . -H
 2. 10120 - 6000EL(), 10320 - 3210 - 000 ()가
 3. MR - JHSCBL M - H, -L IP65 MR - J2CN1
 4. RS - 422
 5.
 6. CN5 1m

C N 3		MR - CPCATCBL3M 3m	-	<p>RS - 232C (3M) DOS/V ()</p> <p>10120 - 3000VE () DE - 9SF - N ()</p> <p>10320 - 52F0 - 008 () (2) DE - C1 - J6 - S6 ()</p> 
C N 4	CN4	MR - H3CBL1M 1m	-	<p>171822 - 4 (AMP)</p> 
C N 5 A	CN5	MR - J2HBUS M : 0.5, 1m (6)	-	<p>10120 - 3000VE (3M) 10120 - 3000VE (3M)</p> <p>10320 - 52F0 - 008 () (2) 10320 - 52F0 - 008 () (2)</p> 
C N 5 B		MR - A - TM	-	
	CN1	MR - HP4CN1	-	<p>10114 - 3000VE (3M)</p> <p>10314 - 52F0 - 008 ()</p> 
		MR - TB20	-	

MR-J2S-700B(4)

(MR-J2S-B)

- A171SH
- A172SH
- A173UH
- A273UH
- AD75M
- A1SD75M

- QD75M

- Q172 (6)
- Q173 (6)

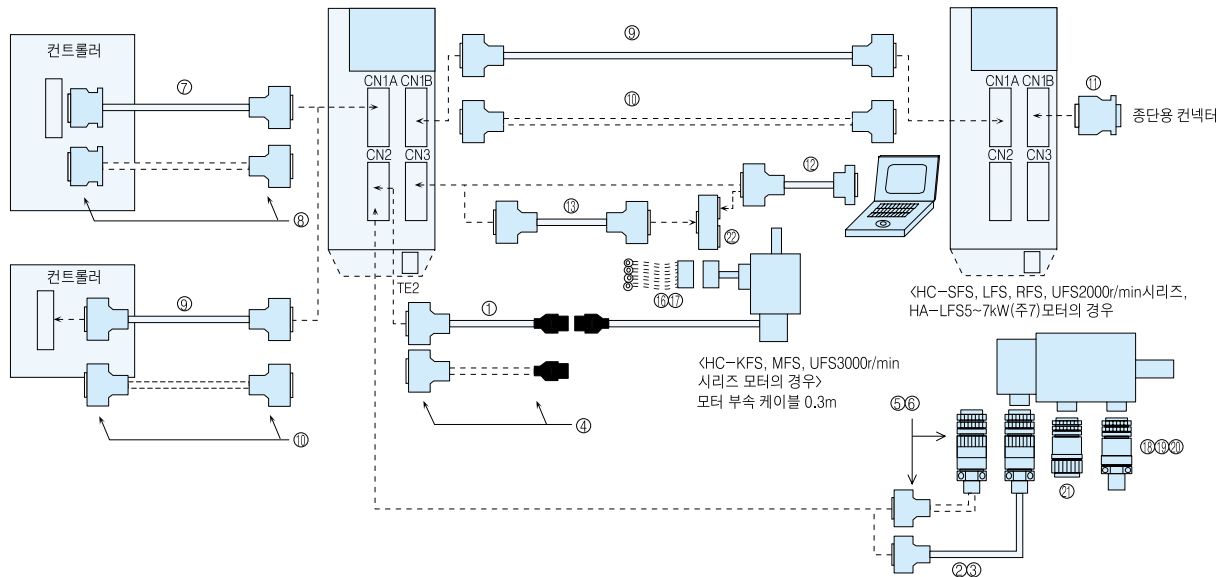

가	CN2	가	가		가	
			가	가	가	가
가	가	가	가	가	가	가
			가	가	가	가
	가	가	가	가	가	가
			가	가	가	가
가	가	가	가	가	가	
		가	가	가	가	
가	가	가	가	가	가	
		가	가	가	가	

1. -H, -L
2. AMP 172161-1() 170363-1() 가
3. 10120-6000EL(), 10320-3210-000()가
4. MR-JHSCBL M-H, -L IP65
- 5.
6. Q172, Q173 Q (L()-03010)a
7. HA-LFS601, 6014, 701M, 701M4

MR-J2S-11KB(4)~MR-J2S-22KB(4)

(MR-J2S-B)

- A171SH
- A172SH
- A173UH
- A273UH
- AD75M
- A1SD75M
- QD75M
- Q172
- Q173 (6)

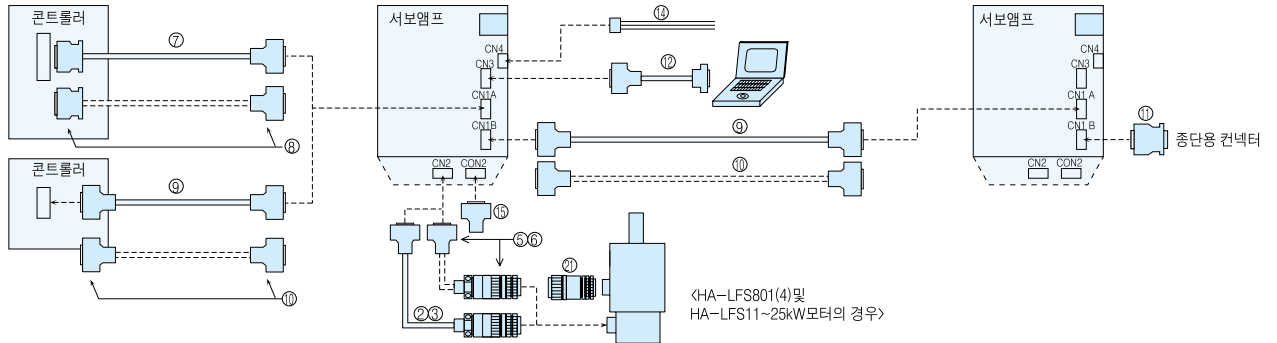

CN1 A, CN1 B		MR - J2HBUS M : 0.5, 1, 5m	-	10120 - 3000VE (3M) 10320 - 52F0 - 008 () (3)	10120 - 3000VE (3M) 10320 - 52F0 - 008 () (3)
	CN1	MR - J2CN1	-	10120 - 3000VE () (3M)	10320 - 52F0 - 008 () (3)
CN1 B		MR - A - TM	-		
CN3		MR - CPCATCBL3M 3m	-	RS - 232C (3M) 10120 - 3000VE () 10320 - 52F0 - 008 () (3)	DOS/V () DE - 9SF - N () DE - C1 - J6 - S6 ()
		MR - J2HBUS M : 0.5, 1, 5m	-	10120 - 3000VE (3M) 10320 - 52F0 - 008 () (3)	10120 - 3000VE (3M) 10320 - 52F0 - 008 () (3)
CN4	CN4	MR - H3CBL1M 1m	-	171822 - 4 (AMP)	11kW
CON2	CON2	MR - J2CMP2	-	10126 - 3000VE (3M)	10326 - 52F0 - 008 ()
가	HC - KFS, MFS, UFS3000r/min	MR - PWCNK1	IP20	(molex) 5559 - 04P - 210	(molex) 5558PBT3L (AWG16)
	HC - KFS, MFS, UFS3000r/min	MR - PWCNK2	IP20	(molex) 5559 - 06P - 210	(molex) 5558PBT3L (AWG16)
	HC - SFS81 HC - SFS52, 102, 152, 524, 1024, 1524 HC - SFS53, 103, 153 HC - LFS52, 102, 152 HC - RFS103, 153, 203 HC - UFS72, 152	MR - PWCNS1 ()	IP65 IP67	() (DDK) CE05 - 6A22 - 23SD - B - BSS	(DDK) CE3057 - 12A - 2 (D265)
	HC - SFS121, 201, 301 HC - SFS202, 352, 502, 2024, 3524, 5024 HC - SFS203, 353 HC - LFS202, 302 HC - RFS353, 503 HA - LFS502 HC - UFS202, 352, 502	MR - PWCNS2 ()	IP65 IP67	() (DDK) CE05 - 6A22 - 10SD - B - BSS	(DDK) CE3057 - 16A - 2 (D265)
	HC - SFS702, 7024 HA - LFS702	MR - PWCNS3 ()	IP65 IP67	() (DDK) CE05 - 6A22 - 17SD - B - BSS	(DDK) CE3057 - 20A - 1 (D265)
	HC - SFS121B, 201B, 301B HC - SFS202B, 352B, 502B, 702B, 2024B, 3524B, 5024B, 7024B HC - SFS203B, 353B HC - LFS202B, 302B HA - LFS601B, 801B, 12K1B, 6014B, 8014B, 12K14B HA - LFS701MB, 11K1MB, 15K1MB, 701M4B, 11K1M4B, 15K1M4B HA - LFS11K2B, 15K2B, 22K2B, 11K24B, 15K24B, 22K24B HC - UFS202B, 352B, 502B	MR - BKCN ()	IP65 IP67	(DDK) MS3106A10SL - 4S (D190)	YSO10 - 5 - 8 () ()
		MR - J2CN3TM	-		11kW MR - J2S - B

MR-J2S-30KB(4)

(MR-J2S-B)

- A171SH
- A172SH
- A173UH
- A273UH
- AD75M
- A1SD75M



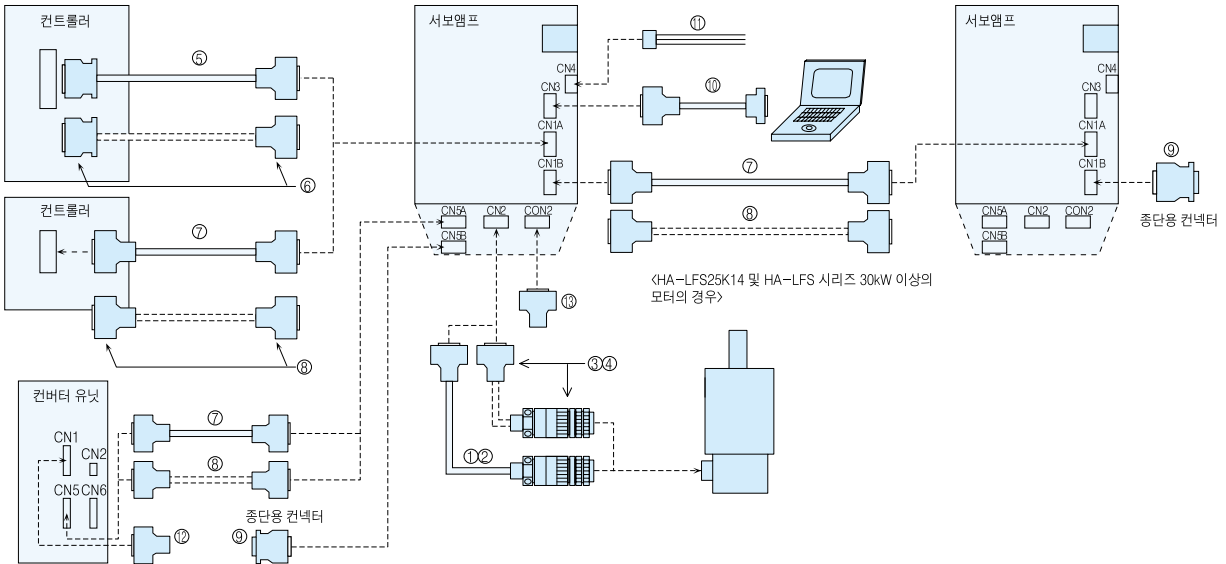

- QD75M

- Q172 (5)
- Q173 (5)

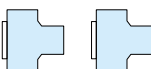

가	CN2	<HA-LFS> (3)	MR-JHSCBL M-H : 2, 5, 10, 20, 30, 50m (1)	IP20	10120-3000VE (3M)) 10320-52F0-008 () (2)	MS3057-12A (DDK)) MS3106B20-29S ())
			MR-JHSCBL M-L : 2, 5, 10, 20, 30m (1)	IP20		
	가	<HA-LFS> (3)	MR-ENCBL M-H : 2, 5, 10, 20, 30, 50m (1, 4)	IP65 IP67	10120-3000VE (3M)) 10320-52F0-008 () (2)	CE02-20BS-S (DDK)) MS3106A20-29S (D190) (DDK)) CE3057-12A-3 (D265) (DDK))
			MR-J2CNS	IP20	10120-3000VE (3M)) 10320-52F0-008 () (2)	MS3057-12A (DDK)) MS3106B20-29S ())
가	CN1A	<HA-LFS> (3)	MR-ENCNS	IP65 IP67	MS3106A20-29S (D190) (DDK)) 10120-3000VE (3M)) 10320-52F0-008 () (2)	CE02-20BS-S (DDK)) CE3057-12A-3 (D265) (DDK))
			MR-J2HBUS M-A : 0.5, 1, 5m	-	PCR-S20FS ()) PCR-LS20LA1 ())	10120-3000VE (3M)) 10320-52F0-008 () (2)
가	CN1A	<HA-LFS> (3)	MR-J2CN1-A	-	PCR-S20FS ()) PCR-LS20LA1 ())	10120-3000VE (3M)) 10320-52F0-008 () (2)

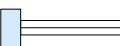
1. -H, -L ... -H
 2. 10120-6000EL(), 10320-3210-000()가
 3. MR-JHSCBL M-H, -L IP65
 4.
 5. Q172, Q173 P Q (L) -03010) a
 6. CN5 1m

CN1 A, CN1 B, CN5 A,	-	MR - J2HBUS M : 0.5, 1, 5m (6)	-	<p>10120 - 3000VE ((3M)) 10320 - 52F0 - 008 () (2)</p> <p>10120 - 3000VE ((3M)) 10326 - 52F0 - 008 ()</p> 
	CN1 CN5	MR - J2CN1	-	 <p>(3M) 10120 - 3000VE () 10320 - 52F0 - 008 () (2)</p>
CC NN 1 5 B,B		MR - A - TM	-	
CN3		MR - CPCATCBL3M 3m	-	<p>RS - 232C (3M) 10120 - 3000VE () 10320 - 52F0 - 008 () (2)</p> <p>DOS/V () DE - 9SF - N () DE - C1 - J6 - S6 ()</p> 
CN4	CN4	MR - H3CBL1M 1m		<p>171822 - 4 ((AMP))</p> 
	CN1	MR - HP4CN1		 <p>(3M) 10114 - 3000VE () 10314 - 52F0 - 008 ()</p>
CON2	CON2	MR - J2CMP2	-	 <p>(3M) 10126 - 3000VE () 10326 - 52F0 - 008 () (2)</p>

MELSERVO J2 Super

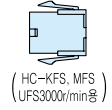
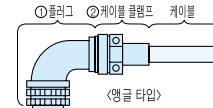
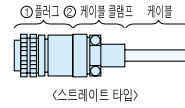

DDK() ()/molex() ()

		DDK()		DDK()	
				(mm)	
HC - SFS81 HC - SFS52, 102, 152, 524, 1024, 1524 HC - SFS53, 103, 153 HC - LFS52, 102, 152 HC - RFS103, 153, 203 HC - UFS72, 152	IP65, IP67 EN	()	CE05 - 6A22 - 23SD - B - BSS	9.5~13	CE3057 - 12A - 2(D265)
				12.5~16	CE3057 - 12A - 1(D265)
			CE05 - 8A22 - 23SD - B - BAS	9.5~13	CE3057 - 12A - 2(D265)
				12.5~16	CE3057 - 12A - 1(D265)
			MS3106B22 - 23S	15.9	MS3057 - 12A
		MS3108B22 - 23S	()	MS3057 - 12A	
HC - SFS121, 201, 301 HC - SFS202, 352, 502, 2024, 3524, 5024 HC - SFS203, 353 HC - LFS202, 302 HC - RFS353, 503 HA - LFS502 HC - UFS202, 352, 502	IP65, IP67 EN	()	CE05 - 6A24 - 10SD - B - BSS	13~15.5	CE3057 - 16A - 2(D265)
				15~19.1	CE3057 - 16A - 1(D265)
			CE05 - 8A24 - 10SD - B - BAS	13~15.5	CE3057 - 16A - 2(D265)
				15~19.1	CE3057 - 16A - 1(D265)
			MS3106B24 - 10S	15.9, 19.1	MS3057 - 16A
		MS3108B24 - 10S	()	MS3057 - 16A	
HC - SFS702, 7024 HA - LFS702	IP65, IP67 EN	()	CE05 - 6A32 - 17SD - B - BSS	22~23.8	CE3057 - 20A - 1(D265)
			CE05 - 8A32 - 17SD - B - BAS	22~23.8	CE3057 - 20A - 1(D265)
			MS3106B32 - 17S	19.1, 23.8	MS3057 - 20A
			MS3108B32 - 17S	()	MS3057 - 20A

) EN

		Molex()	
HC - KFS, MFS, UFS3000 r/min	EN	B	5559 - 04P - 210 5558PBT3L (AWG16)
		B	5559 - 06P - 210 5558PBT3L (AWG16)

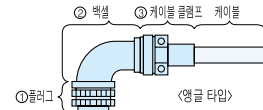
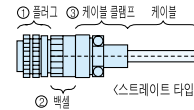

DDK() ()

		DDK()		DDK()	
				(mm)	
HC - SFS, LFS, RFS, HA - LFS, HC - UFS2000r/min	IP65, IP67	MS3106A20 - 29S(D190)	CE02 - 20BS - S	6.8~10	CE3057 - 12A - 3(D265)
			CE - 20BA - S		

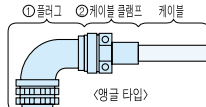
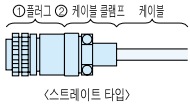

		DDK()		DDK()	
				(mm)	
HC - SFS, LFS, RFS, HA - LFS, HC - UFS2000r/min			MS3106B20 - 29S	15.9	MS3057 - 12A
			MS3108B20 - 29S		

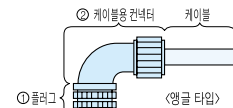
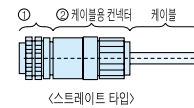

DDK() () / () / ()

		DDK()		DDK()	
				(mm)	
HC - SFS121B, 201B, 301B HC - SFS202B, 352B, 502B, 702B, 2024B, 3524B, 5024B, 7024B HC - SFS203B, 353B HC - LFS202B, 302B HC - UFS202B, 352B, 502B	IP65 IP67	MS3106A10SL - 4S(D190)	4~8	ACS - 08RL - MS10F	()
			8~12	ACS - 12RL - MS10F	()
			5~8.3	YSO10 - 5~8	()
			4~8	ACA - 08RL - MS10F	()
			8~12	ACA - 12RL - MS10F	()
			5~8.3	YLO10 - 5~8	()

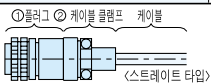

		DDK()		DDK()	
				(mm)	
HC - SFS121B, 201B, 301B HC - SFS202B, 352B, 502B, 702B, 2024B, 3524B, 5024B, 7024B HC - SFS203B, 353B HC - LFS202B, 302B HA - LFS601B, 801B, 12K1B, 6014B, 8014B, 12K14B HA - LFS701MB, 11K1MB, 15K1MB, 701M4B, 11K1M4B, 15K1M4B HA - LFS11K2B, 15K2B, 22K2B, 11K24B, 15K24B, 22K24B HC - UFS202B, 352B, 502B		MS3106A10SL - 4S		5.6	MS3057 - 4A

11kW

가

DBU - 11K	MR - J2S - 11KA/B	A
DBU - 15K	MR - J2S - 15KA/B	
DBU - 22K	MR - J2S - 22KA/B	
DBU - 11K - 4	MR - J2S - 11KA4/B4	B
DBU - 22K - 4	MR - J2S - 15KA4/B4 MR - J2S - 22KA4/B4	

DBU - 37K	MR - J2S - 30KA/B MR - J2S - 37KA/B	C
DBU - 55K - 4	MR - J2S - 30KA4/B4 MR - J2S - 37KA4/B4	
	MR - J2S - 45KA4/B4 MR - J2S - 55KA4/B4	

(: mm)

단자대 (GND) a b 13 14 U V W
나사사이즈 : M3.5 나사사이즈 : M4

	A	B	C	D	E	F	G	(kg)	(mm)
DBU - 11K	200	190	140	20	5	170	163.5	2	5.5(AWG10)
DBU - 15K	250	238	150	25	6	235	228	6	5.5(AWG10)
DBU - 22K									

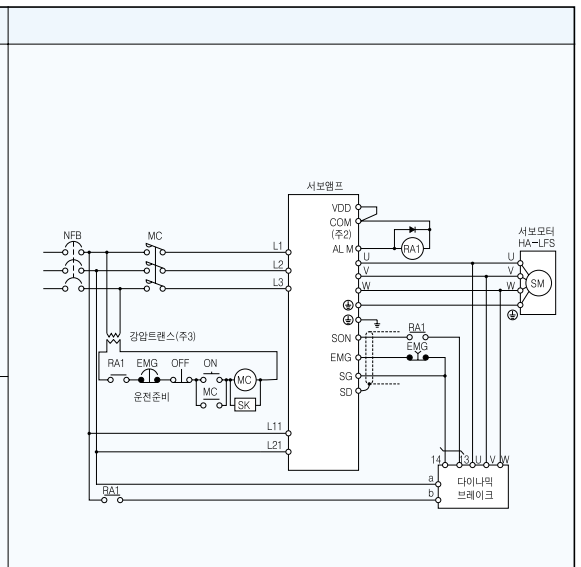

(: mm)

TE1 a b 13 14 U V W
나사사이즈 : M3,5

TE2 U V W
나사사이즈 : M4

	(kg)	(mm)	
		U, V, W	U, V, W
DBU - 11K - 4	6.7	5.5 (AWG10)	2 (AWG14)
DBU - 22K - 4			

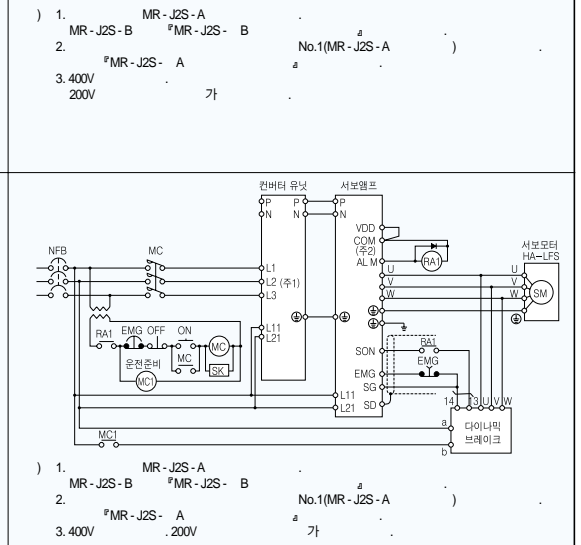

(: mm)

TE1 U V W
나사사이즈 : M5

TE2 a b 13 14 U V W
나사사이즈 : M3,5

	(kg)	(mm)	
		U, V, W	U, V, W
DBU - 37K	8	14 (AWG6)	2 (AWG14)
DBU - 55K - 4	11		

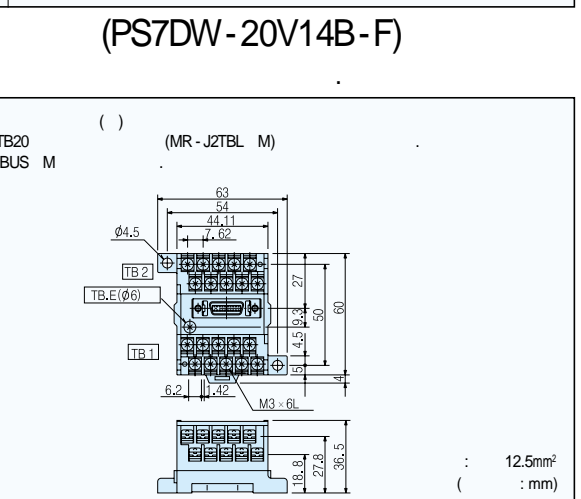

(MR-TB20)

(PS7DW-20V14B-F)

CN1

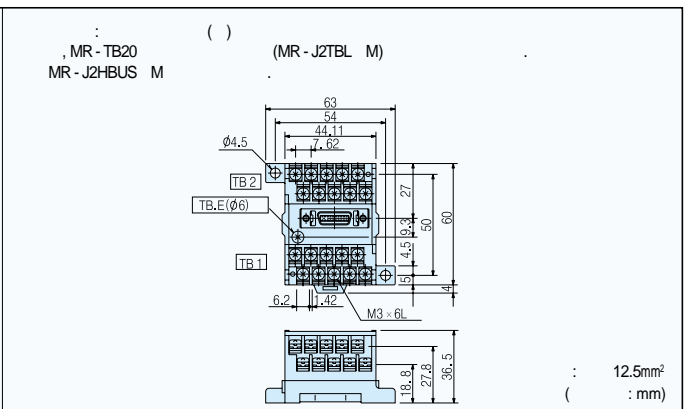
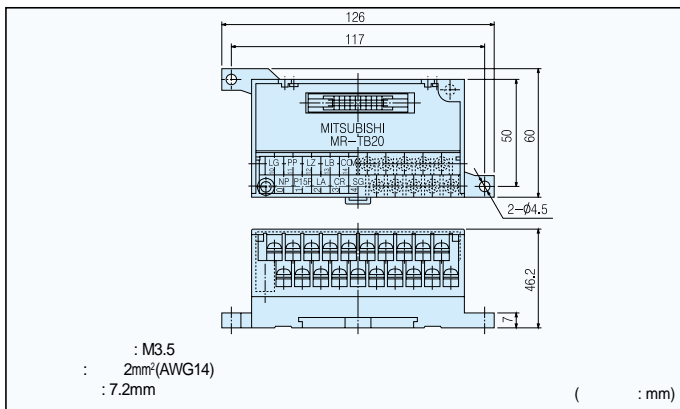

MELSERVO J2 Super

(MR-J2S-)	/ (W)	() / (W)					
		GRZG400-					
		2 x 4	1 x 5	0.8 x 5	5 x 4	2.5 x 5	2 x 5
10A(1)/B(1)/CP(1)/CL(1)	-	-	-	-	-	-	-
20A(1)/B(1)/CP(1)/CL(1)	10	-	-	-	-	-	-
40A(1)/B(1)/CP(1)/CL(1)	10	-	-	-	-	-	-
60A/B/CP/CL	10	-	-	-	-	-	-
70A/B/CP/CL(-U)	20	-	-	-	-	-	-
100A/B/CP/CL	20	-	-	-	-	-	-
200A/B/CP/CL	100	-	-	-	-	-	-
350A/B/CP/CL	100	-	-	-	-	-	-
500A/B/CP/CL	130	-	-	-	-	-	-
700A/B/CP/CL	170	-	-	-	-	-	-
11KA/B	-	500(800)	-	-	-	-	-
15KA/B	-	-	850(1300)	-	-	-	-
22KA/B	-	-	-	850(1300)	-	-	-
30KA/B	-	-	-	-	-	-	-
37KA/B	-	-	-	-	-	-	-
60A4/B4	10	-	-	-	-	-	-
100A4/B4	20	-	-	-	-	-	-
200A4/B4	100	-	-	-	-	-	-
350A4/B4	100	-	-	-	-	-	-
500A4/B4	130	-	-	-	-	-	-
700A4/B4	170	-	-	-	-	-	-
11KA4/B4	-	-	-	-	500(800)	-	-
15KA4/B4	-	-	-	-	-	850(1300)	-
22KA4/B4	-	-	-	-	-	-	850(1300)
30KA4/B4	-	-	-	-	-	-	-
37KA4/B4	-	-	-	-	-	-	-
45KA4/B4	-	-	-	-	-	-	-
55KA4/B4	-	-	-	-	-	-	-

1. W W
2. () (1.0m³/min, 92x2) No.0(MR-J2S-A) No.2(MR-J2S-B)
3. MR-RB137 MR138-4 3

MR-RB032, MR-RB12

	:M5				(kg)
	LA	LB	LC	LD	
MR-RB032	30	15	119	99	0.5
MR-RB12	40	15	169	149	1.1

단자나사 사이즈:M3

MR-RB30, MR-RB31, MR-RB32

	:M6		(kg)
	MR-RB30	MR-RB31	
MR-RB30	2.9	2.9	2.9
MR-RB31	2.9	2.9	2.9
MR-RB32	2.9	2.9	2.9

단자나사 사이즈:M4

<MR-J2S-350 >

1. MR-RB50 (1.0m³/min, 92) (MC)

MR-RB50, MR-RB51

	:M6		(kg)
	MR-RB50	MR-RB51	
MR-RB50	5.6	5.6	5.6
MR-RB51	5.6	5.6	5.6

단자나사 사이즈:M4

<MR-J2S-500, 700 >

1. MR-RB50, MR-RB51 (1.0m³/min, 92) (MC)

GRZG400-2, GRZG400-1, GRZG400-0.8 : (1.5)

	(W)	(W)	()	(kg/)
GRZG400-2	4	500	8(2 x 4)	0.8
GRZG400-1	5	850	5(1 x 5)	0.8
GRZG400-0.8	5	850	4(0.8 x 5)	0.8

단락 바를 떼어내지 마십시오.
각 저항기 사이는 70mm 이상 간격을 두십시오.
직렬접속
트위스트

서보앰프 MR-J2S-11KA/B ~22KA/B

		(W)																	()								
		MR - RB																	()								
		032	12	30	31	32	50	51	65	66	67	139	137	1L-4	3M-4	3H-4	3G-4	34-4	5H-4	5G-4	54-4	6B-4	60-4	6K-4	136-4	138-4	()
x	x	x	x	x	x	x	x	x	x	x	x	x	x	x	x	x	x	x	x	x	x	x	x	x	x	x	40
x	x	100	x	x	x	x	x	x	x	x	x	x	x	x	x	x	x	x	x	x	x	x	x	x	x	x	40
x	x	100	x	x	x	x	x	x	x	x	x	x	x	x	x	x	x	x	x	x	x	x	x	x	x	x	40
x	x	100	x	x	x	x	x	x	x	x	x	x	x	x	x	x	x	x	x	x	x	x	x	x	x	x	40
x	x	100	x	x	x	300	x	x	x	x	x	x	x	x	x	x	x	x	x	x	x	x	x	x	x	x	40
x	x	100	x	x	300	x	x	x	x	x	x	x	x	x	x	x	x	x	x	x	x	x	x	x	x	x	40
x	x	x	300	x	x	500	x	x	x	x	x	x	x	x	x	x	x	x	x	x	x	x	x	x	x	x	13
x	x	x	300	x	x	500	x	x	x	x	x	x	x	x	x	x	x	x	x	x	x	x	x	x	x	x	13
x	x	x	x	300	x	x	500	x	x	x	x	x	x	x	x	x	x	x	x	x	x	x	x	x	x	x	13
x	x	x	x	300	x	x	500	x	x	x	x	x	x	x	x	x	x	x	x	x	x	x	x	x	x	x	6.7
x	x	x	x	300	x	x	500	x	x	x	x	x	x	x	x	x	x	x	x	x	x	x	x	x	x	x	8
x	x	x	x	300	x	x	500	x	x	x	x	x	x	x	x	x	x	x	x	x	x	x	x	x	x	x	5
x	x	x	x	300	x	x	500	x	x	x	x	x	x	x	x	x	x	x	x	x	x	x	x	x	x	x	4
x	x	x	x	300	x	x	500	x	x	x	x	x	x	x	x	x	x	x	x	x	x	x	x	x	x	x	1.3(3)
x	x	x	x	300	x	x	500	x	x	x	x	x	x	x	x	x	x	x	x	x	x	x	x	x	x	x	1.3(3)
x	x	x	x	300	x	x	500	x	x	x	x	x	x	x	x	x	x	x	x	x	x	x	x	x	x	x	270
x	x	x	x	300	x	x	500	x	x	x	x	x	x	x	x	x	x	x	x	x	x	x	x	x	x	x	120
x	x	x	x	300	x	x	500	x	x	x	x	x	x	x	x	x	x	x	x	x	x	x	x	x	x	x	80
x	x	x	x	300	x	x	500	x	x	x	x	x	x	x	x	x	x	x	x	x	x	x	x	x	x	x	47
x	x	x	x	300	x	x	500	x	x	x	x	x	x	x	x	x	x	x	x	x	x	x	x	x	x	x	47
x	x	x	x	300	x	x	500	x	x	x	x	x	x	x	x	x	x	x	x	x	x	x	x	x	x	x	26
x	x	x	x	300	x	x	500	x	x	x	x	x	x	x	x	x	x	x	x	x	x	x	x	x	x	x	20
x	x	x	x	300	x	x	500	x	x	x	x	x	x	x	x	x	x	x	x	x	x	x	x	x	x	x	12.5
x	x	x	x	300	x	x	500	x	x	x	x	x	x	x	x	x	x	x	x	x	x	x	x	x	x	x	10
x	x	x	x	300	x	x	500	x	x	x	x	x	x	x	x	x	x	x	x	x	x	x	x	x	x	x	5(3)
x	x	x	x	300	x	x	500	x	x	x	x	x	x	x	x	x	x	x	x	x	x	x	x	x	x	x	5(3)
x	x	x	x	300	x	x	500	x	x	x	x	x	x	x	x	x	x	x	x	x	x	x	x	x	x	x	5(3)
x	x	x	x	300	x	x	500	x	x	x	x	x	x	x	x	x	x	x	x	x	x	x	x	x	x	x	5(3)

MR-RB65, MR-RB66, MR-RB67 (1.5)

설치나사 사이즈 : M8

	(M)	(W)		(kg)
MR - RB65	500	800	GRZG400 - 2 x 4	10
MR - RB66	850	1300	GRZG400 - 1 x 5	11
MR - RB67	850	1300	GRZG400 - 0.8 x 5	11

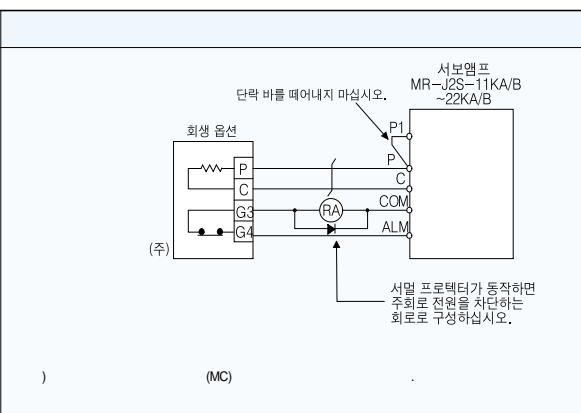

MR-RB139, MR-RB137

설치나사 사이즈 : M8

	(M)	(W)	(kg)
MR - RB139	1300		10
MR - RB137	3900(3)		11

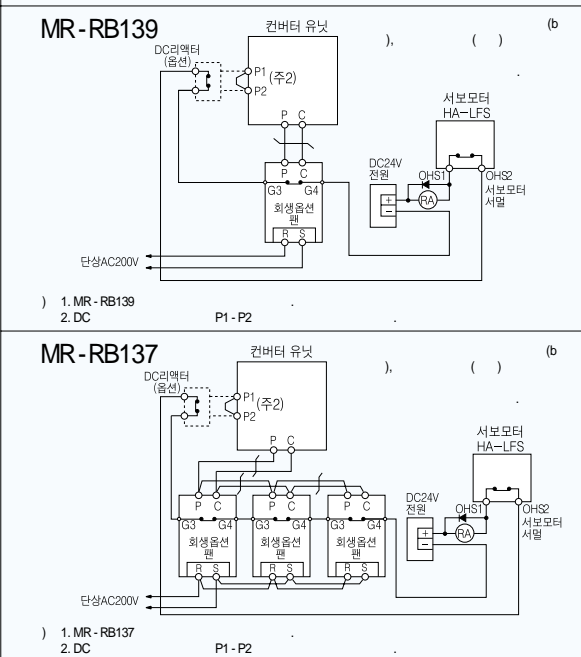

- MR - J2S - 11KA/B ~ 22KA/B (MR - J2S - K - FX)
- 100
- (5m)
- (1.0m²/min, 92 x 2)
- No.0(MR - J2S - A) No.2(MR - J2S - B)

(: mm)

MR-RB1L-4

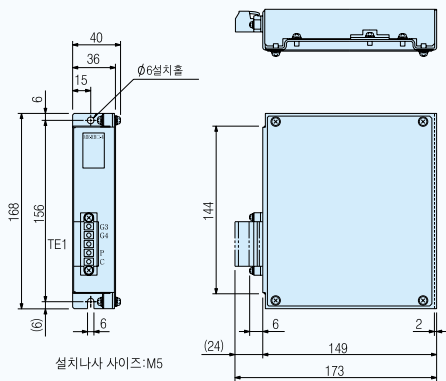

<단자배열>

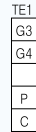

단자나사 사이즈:M3

	(kg)
MR-RB1L-4	1.1

MR-J2S-200A4/B4

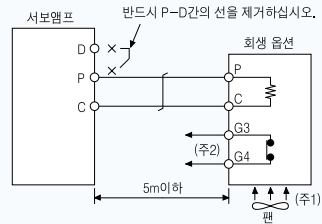

1. MR-RB5H-4 (1.0m²/min, 92)
2. (MC)

MR-J2S-350A4/B4~700A4/B4

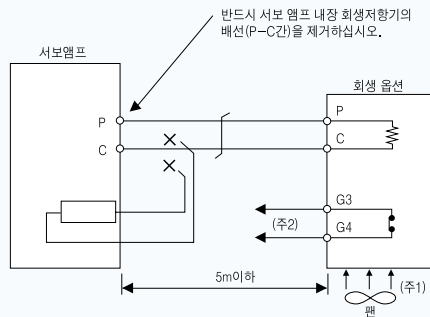

1. MR-RB5G-4, MR-RB54-4 (1.0m²/min, 92)
2. (MC)

MR-RB3M-4, MR-RB3H-4, MR-RB3G-4, MR-RB34-4

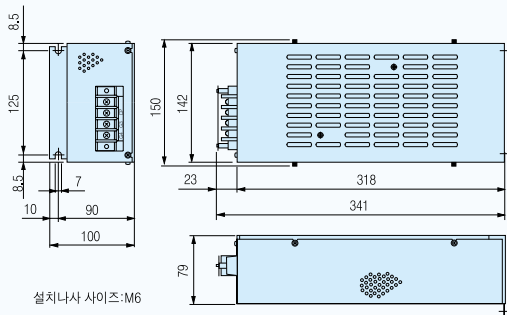

<단자배열>



단자나사 사이즈:M4

	(kg)
MR-RB3M-4	2.9
MR-RB3H-4	2.9
MR-RB3G-4	2.9
MR-RB34-4	2.9

MR-RB5H-4, MR-RB5G-4, MR-RB54-4

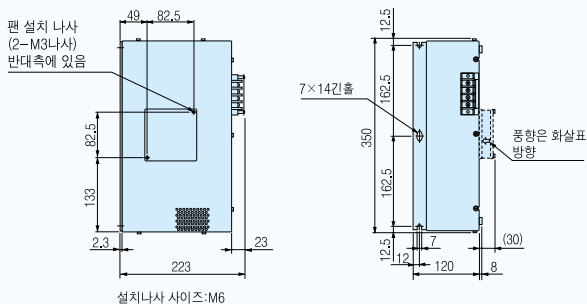

<단자배열>



단자나사 사이즈:M4

	(kg)
MR-RB5H-4	5.6
MR-RB5G-4	5.6
MR-RB54-4	5.6

(: mm)

GRZG400-5 , GRZG400-2.5 , GRZG400-2 : (1,5)

		(W)	(W)	()	(kg/)
GRZG400-5	4	500	800	20(5 x 4)	0.8
GRZG400-2.5	5	850	1300	12.5(2.5 x 5)	0.8
GRZG400-2	5	850	1300	10(2 x 5)	0.8

설치나사 사이즈: M8

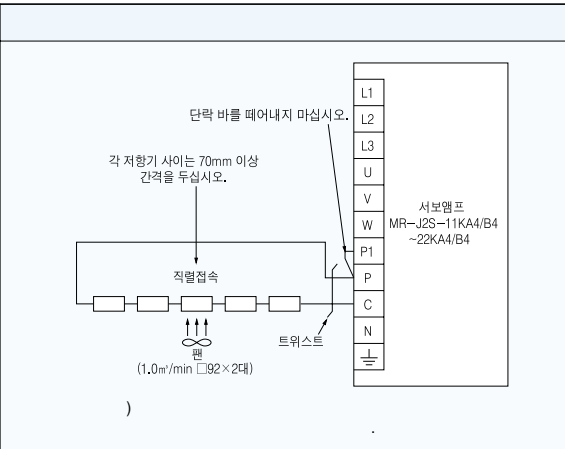

MR-RB6B-4, MR-RB60-4, MR-RB6K-4 (1,5)

<단자배열>
TE1 G4 G3 C P
단자나사 사이즈 : M5

	(W)	(W)		(kg)
MR-RB6B-4	500	800	GRZG400-5 x 4	10
MR-RB60-4	850	1300	GRZG400-2.5 x 5	11
MR-RB6K-4	850	1300	GRZG400-2 x 5	11

설치나사 사이즈 : M8

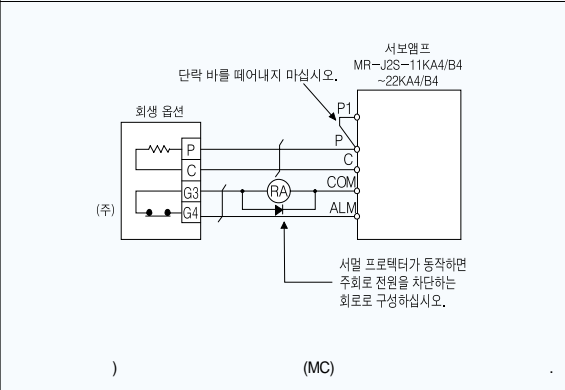

MR-RB136-4, MR-RB138-4

<단자배열>
R400 S400 G4 G3 C P
단자나사 사이즈 : M5

	(W)	(kg)
MR-RB136-4	1300	10
MR-RB138-4	3900(3)	11

MR-RB138-4 1 3 가

설치나사 사이즈 : M8

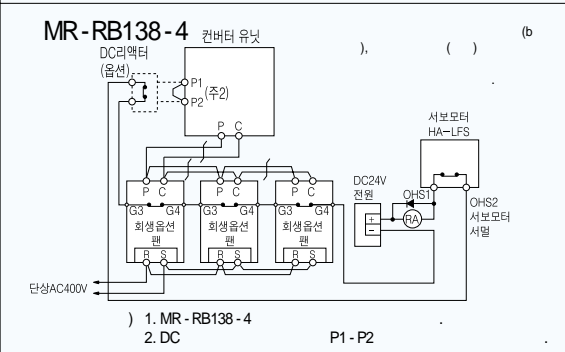
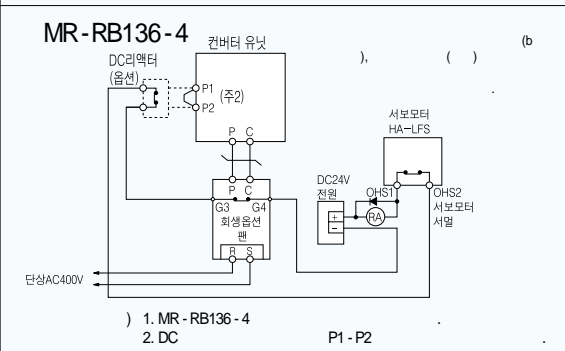

1. MR-J2S-11KA4/B4~22KA4/B4 (MR-J2S- K 4-PX) 가, () ,
2. 100 가, () ,
3. (5m) ,
4. (1.0m³/min, 92 x 2) , No.0(MR-J2S-A)) No.2(MR-J2S-B))
5. 가

(MR-BAT)

가
) 1. A6BAT 가
 2. (IATA) (44) 2003 1 1

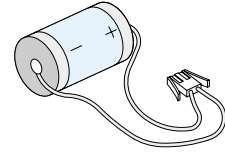

가 「 」 가
 (Class9) , 24

	MR - BAT
	3.6V
	1700mAh
	0.48g

24 903 가

(2005 3)

(MR-J2CN3TM) ... MR-J2S-700A(4)/B(4)/CP/CL

1. MR-J2S-11KA(4)/B(4)
MR-H3CBL1M

MR-J2HBUS M CN4

	(Kg)
MR-J2CN3TM	0.11

1. CC-Link (MR-J2S-CP-S084)

(MR-HDP01) ... MR-J2S-CP

MR-J2S-CL

(1)

패널 컷트

1. CC-Link (MR-J2S-CP-S084)
2. CN1 (MR-J2CN1)

(MR-DP60) ... MR-J2S-CP

MR-J2S-CL

<정면설치의 경우>

<내면설치의 경우>

1. MR-DP60 No.16
2. CN1 (MR-J2CN1)

(MR-(J)ACN)

50%

(: mm)			(: mm)																																			
<p><MR-JACN15K> <MR-JACN22K> <MR-ACN(P) K></p>	<p><MR-JACN K> <MR-ACN(P) K></p>	<table border="1"> <thead> <tr> <th></th> <th></th> <th>DA</th> <th>DB</th> <th>DC</th> <th>DD</th> </tr> </thead> <tbody> <tr> <td>MR-JACN15K</td> <td>MR-J2S-11KA/B MR-J2S-15KA/B MR-J2S-11KA4/B4 MR-J2S-15KA4/B4</td> <td>203</td> <td>236</td> <td>255</td> <td>270</td> </tr> <tr> <td>MR-JACN22K</td> <td>MR-J2S-22KA/B MR-J2S-12KA4/B4</td> <td>290</td> <td>326</td> <td>345</td> <td>360</td> </tr> <tr> <td>MR-ACNP55K</td> <td>MR-HP30KA MR-HP55KA4</td> <td>205</td> <td>156</td> <td>110</td> <td>190</td> </tr> <tr> <td>MR-ACN30K</td> <td>MR-J2S-30KA4/B4</td> <td>385</td> <td>336</td> <td>290</td> <td>370</td> </tr> <tr> <td>MR-ACN55K</td> <td>MR-J2S-30KA/B MR-J2S-37KA/B MR-J2S-37KA4/B4 MR-J2S-45KA4/B4 MR-J2S-55KA4/B4</td> <td>455</td> <td>406</td> <td>360</td> <td>440</td> </tr> </tbody> </table>			DA	DB	DC	DD	MR-JACN15K	MR-J2S-11KA/B MR-J2S-15KA/B MR-J2S-11KA4/B4 MR-J2S-15KA4/B4	203	236	255	270	MR-JACN22K	MR-J2S-22KA/B MR-J2S-12KA4/B4	290	326	345	360	MR-ACNP55K	MR-HP30KA MR-HP55KA4	205	156	110	190	MR-ACN30K	MR-J2S-30KA4/B4	385	336	290	370	MR-ACN55K	MR-J2S-30KA/B MR-J2S-37KA/B MR-J2S-37KA4/B4 MR-J2S-45KA4/B4 MR-J2S-55KA4/B4	455	406	360	440
		DA	DB	DC	DD																																	
MR-JACN15K	MR-J2S-11KA/B MR-J2S-15KA/B MR-J2S-11KA4/B4 MR-J2S-15KA4/B4	203	236	255	270																																	
MR-JACN22K	MR-J2S-22KA/B MR-J2S-12KA4/B4	290	326	345	360																																	
MR-ACNP55K	MR-HP30KA MR-HP55KA4	205	156	110	190																																	
MR-ACN30K	MR-J2S-30KA4/B4	385	336	290	370																																	
MR-ACN55K	MR-J2S-30KA/B MR-J2S-37KA/B MR-J2S-37KA4/B4 MR-J2S-45KA4/B4 MR-J2S-55KA4/B4	455	406	360	440																																	

(FR-BIF, FR-BIF-H)

가 , 10MHz

FR-BIF	MR-J2S-22K , MR-J2S-30K	37K
FR-BIF-H	MR-J2S-60 4-MR-J2S-55K	4

(: mm)	
	<p><MR-J2S-22K (4) ></p> <p><MR-J2S-30K (4) ></p> <p>1. FR-BIF 2. FR-BIF-H 3. FR-BIF</p>

(FR-BSF01, FR-BLF)

가 0.5MHz ~ 5MHz 가

(: mm)	
<p>• FR-BSF01 <MR-J2S-200 (4) ></p>	<p>가 가 4 가 가 () 가</p>
<p>• FR-BLF <MR-J2S-350 (4) ></p>	<p><MR-J2S-22K (4) ></p> <p><MR-J2S-30K (4) ></p>

(FR-BAL, FR-BEL, MR-DCL)

가

AC	FR-BAL-0.4K	MR-J2S-10A/A1/B/B1/CP/CP1/CL/CL1 MR-J2S-20A/B/CP/CL	A
	FR-BAL-0.75K	MR-J2S-40A/B/CP/CL MR-J2S-20A1/B1/CP1/CL1	
	FR-BAL-1.5K	MR-J2S-60A/B/CP/CL MR-J2S-70A/B/CP/CL(-U) MR-J2S-40A1/B1/CP1/CL1	
	FR-BAL-2.2K	MR-J2S-100A/B/CP/CL	
	FR-BAL-3.7K	MR-J2S-200A/B/CP/CL	
	FR-BAL-7.5K	MR-J2S-350A/B/CP/CL	
	FR-BAL-11K	MR-J2S-500A/B/CP/CL	
	FR-BAL-15K	MR-J2S-700A/B/CP/CL MR-J2S-11KA/B	
	FR-BAL-22K	MR-J2S-15KA/B	
	FR-BAL-30K	MR-J2S-22KA/B	

AC	FR-BAL-H1.5K	MR-J2S-60A4/B4	A		
	FR-BAL-H2.2K	MR-J2S-100A4/B4			
	FR-BAL-H3.7K	MR-J2S-200A4/B4			
	FR-BAL-H7.5K	MR-J2S-350A4/B4			
	FR-BAL-H11K	MR-J2S-500A4/B4			
	FR-BAL-H15K	MR-J2S-700A4/B4 MR-J2S-11KA4/B4			
	FR-BAL-H22K	MR-J2S-15KA4/B4			
	FR-BAL-H30K	MR-J2S-22KA4/B4			
	DC	FR-BEL-15K		MR-J2S-11KA/B	B
		FR-BEL-22K		MR-J2S-15KA/B	
FR-BEL-30K		MR-J2S-22KA/B			
FR-BEL-H15K		MR-J2S-11KA4/B4			
FR-BEL-H22K		MR-J2S-15KA4/B4			
FR-BEL-H30K		MR-J2S-22KA4/B4			
MR-DCL30K		MR-J2S-30KA/B	C		
MR-DCL37K		MR-J2S-37KA/B			
MR-DCL30K-4		MR-J2S-30KA4/B4			
MR-DCL37K-4		MR-J2S-37KA4/B4			
MR-DCL45K-4	MR-J2S-45KA4/B4				
MR-DCL55K-4	MR-J2S-55KA4/B4				

(: mm)

	(mm)									(kg)
	W	W1	H	D	D1	C				
FR-BAL-0.4K	135	120	115	59	45 ^{+0.25}	7.5	M4	M3.5	2.0	
FR-BAL-0.75K	135	120	115	69	57 ^{+0.25}	7.5	M4	M3.5	2.8	
FR-BAL-1.5K	160	145	140	71	55 ^{+0.25}	7.5	M4	M3.5	3.7	
FR-BAL-2.2K	160	145	140	91	75 ^{+0.25}	7.5	M4	M3.5	5.6	
FR-BAL-3.7K	220	200	192	90	70 ^{+0.25}	10	M5	M4	8.5	
FR-BAL-7.5K	220	200	194	120	100 ^{+0.25}	10	M5	M5	14.5	
FR-BAL-11K	280	255	220	135	100 ^{+0.25}	12.5	M6	M6	19	
FR-BAL-15K	295	270	275	133	110 ^{+0.25}	12.5	M6	M6	27	
FR-BAL-22K	290	240	301	199	170±0.5	25	M8	M8	35	
FR-BAL-30K	290	240	301	219	190±0.5	25	M8	M8	43	
FR-BAL-H1.5K	160	145	140	87	70 ^{+0.25}	7.5	M4	M3.5	5.3	
FR-BAL-H2.2K	160	145	140	91	75 ^{+0.25}	7.5	M4	M3.5	5.9	
FR-BAL-H3.7K	220	200	190	90	70 ^{+0.25}	10	M5	M3.5	8.5	
FR-BAL-H7.5K	220	200	192	120	100±0.5	10	M5	M4	14	
FR-BAL-H11K	280	255	226	130	100±0.5	12.5	M6	M5	18.5	
FR-BAL-H15K	295	270	244	130	110±0.5	12.5	M6	M5	27	
FR-BAL-H22K	290	240	269	199	170±0.5	25	M8	M8	35	
FR-BAL-H30K	290	240	290	219	190±0.5	25	M8	M8	43	

	(mm)										(kg)	(mm)
	A	B	C	D	E	F	L	G	H			
FR-BEL-15K	170	93	170	2.3	155	6	14	M8	56	M5	3.8	22(AWG4)
FR-BEL-22K	185	119	182	2.6	165	7	15	M8	70	M6	5.4	30(AWG2)
FR-BEL-30K	185	119	201	2.6	165	7	15	M8	70	M6	6.7	60(AWG2/0)
FR-BEL-H15K	170	93	160	2.3	155	6	14	M6	56	M5	3.7	8(AWG8)
FR-BEL-H22K	185	119	171	2.6	165	7	15	M6	70	M6	5.0	22(AWG4)
FR-BEL-H30K	185	119	189	2.6	165	7	15	M6	70	M6	6.7	22(AWG4)

	(mm)							(kg)	(mm)
	A	B	B1	C	D				
MR-DCL30K	255	135	80	215	232	M12	9.5	60(AWG2/0)	
MR-DCL37K								80(AWG3/0)	
MR-DCL30K-4	205	135	75	200	175	M8	6.5	30(AWG2)	
MR-DCL37K-4	225	135	80	200	197	M8	7	38(AWG2)	
MR-DCL45K-4	240	135	80	200	212	M8	7.5	50(AWG1/0)	
MR-DCL55K-4	260	135	80	215	232	M8	9.5	60(AWG2/0)	

			(mm ²)						
			L1, L2, L3, ⊕	L11, L21, 24V · L11, 0V · L21(6)	U, V, W, ⊕	P, C (7)	BU, BV, BW	B1, B2	OHS1, OHS2
MR-J2S-10A/A1/B/B1/CP/CP1/CL/CL1	30A	5A	S - N10	2(AWG14)	1.25 (AWG16)	2 (AWG14)	-	1.25 (AWG16)	-
MR-J2S-20A/B/CP/CL	30A	10A							
MR-J2S-40A/B/CP/CL	30A	15A							
MR-J2S-20A1/B1/CP1/CL1									
MR-J2S-60A/B/CP/CL									
MR-J2S-40A1/B1/CP1/CL1	30A	20A							
MR-J2S-70A/B/CP/CL(-U)									
MR-J2S-100A/B/CP/CL	30A	20A	S - N18	3.5(AWG12)	5.5(AWG10)	-	(3)	1.25 (AWG16)	(4)
MR-J2S-200A/B/CP/CL	30A	20A	S - N20	5.5(AWG10)	5.5(AWG10)				
MR-J2S-350A/B/CP/CL	30A	30A	S - N20	5.5(AWG10)	5.5(AWG10)	-	(3)	1.25 (AWG16)	(4)
MR-J2S-500A/B/CP/CL	50A	50A	S - N35	5.5(AWG10)	5.5(AWG10)				
MR-J2S-700A/B/CP/CL	100A	75A	S - N50	8(AWG8)	8(AWG8)	3.5(AWG12)	-	1.25 (AWG16)	(4)
MR-J2S-11KA/B	100A	100A	S - N65	14(AWG6)	22(AWG4)	5.5 (AWG10)			
MR-J2S-15KA/B	225A	125A	S - N95	22(AWG4)	30(AWG2/5)		-	(3)	1.25 (AWG16)
MR-J2S-22KA/B	225A	175A	S - N125	50(AWG1/0)	60 (AWG2/0)	2 (AWG14)			
MR-J2S-30KA/B	400A	250A	S - N150	50(AWG1/0)	80(AWG3/0)		-	(3)	1.25 (AWG16)
MR-J2S-37KA/B	400A	300A	S - N180	60(AWG2/0)	80(AWG3/0)	-			
MR-J2S-60A4/B4	30A	5A	S - N10	2(AWG14)	1.25 (AWG16)		2 (AWG14)	-	1.25 (AWG16)
MR-J2S-100A4/B4	30A	10A							
MR-J2S-200A4/B4	30A	15A							
MR-J2S-350A4/B4	30A	20A	S - N18	3.5(AWG12)	5.5(AWG10)	-	(3)	1.25 (AWG16)	(4)
MR-J2S-500A4/B4	30A	30A							
MR-J2S-700A4/B4	50A	40A	S - N20	5.5(AWG10)	5.5(AWG10)	-	(3)	1.25 (AWG16)	(4)
MR-J2S-11KA4/B4	60A	60A	S - N25	8(AWG8)	8(AWG8)				
MR-J2S-15KA4/B4	100A	75A	S - N35	14(AWG6)	22(AWG4)	-	(3)	1.25 (AWG16)	(4)
MR-J2S-22KA4/B4	225A	125A	S - N65	22(AWG4)	30(AWG2)				
MR-J2S-30KA4/B4	225A	150A	S - N95	22(AWG4)	30(AWG2)	-	(3)	1.25 (AWG16)	(4)
MR-J2S-37KA4/B4	225A	175A	S - N125	30(AWG2)	30(AWG2)				
MR-J2S-45KA4/B4	225A	225A	S - N150	30(AWG2)	50(AWG1/0)	-	(3)	1.25 (AWG16)	(4)
MR-J2S-55KA4/B4	400A	250A	S - N180	50(AWG1/0)	60(AWG2/0)				

- 1. 600V 30m
- 2. HC - RFS203 3.5mm²(AWG12)
- 3. HA - LFS601(4) HA - LFS701M(4) 2mm²(AWG14)
- 4. HA - LFS601(4) HA - LFS701M(4) 1.25mm²(AWG16)
- 5. MR - J2S - 15KA/B U, V, W 38 - S6() R38 - 6S()
- 6. 24V · L11, 0V · L21 MR - J2S - 60A4/B4~700A4/B4
- 7. 5m

AC , AC (QD75D)
 DC , DC
 AC : 972A - 2003 504 11 (AC200V 松尾電機製)
 DC : ESD - SR - 25 () ZCAT3035 - 1330 (TDK)
 2 4

EMC

EMC

SF1252	MR - J2S - 10A/B/CP/CL~ 100A/B/CP/CL MR - J2S - 10A1/B1/CP1/CL1~ 40A1/B1/CP1/CL1	A
SF1253	MR - J2S - 200A/B/CP/CL MR - J2S - 350A/B/CP/CL	B
HF3040A - TM()	MR - J2S - 500A/B/CP/CL	C
HF3050A - TM()	MR - J2S - 700A/B/CP/CL	
HF3060A - TMA()	MR - J2S - 11KA/B	
HF3080A - TMA()	MR - J2S - 15KA/B	
HF3100A - TMA()	MR - J2S - 22KA/B	D
HF3200A - TMA()	MR - J2S - 30KA/B MR - J2S - 37KA/B	

TF3005C - TX()	MR - J2S - 60A4/B4 MR - J2S - 100A4/B4 MR - J2S - 200A4/B4	E
TF3020C - TX()	MR - J2S - 350A4/B4 MR - J2S - 500A4/B4 MR - J2S - 700A4/B4	
TF3030C - TX()	MR - J2S - 11KA4/B4	
TF3040C - TX()	MR - J2S - 15KA4/B4	F
TF3060C - TX()	MR - J2S - 22KA4/B4	
TF3150C - TX()	MR - J2S - 30KA4/B4 MR - J2S - 37KA4/B4 MR - J2S - 45KA4/B4 MR - J2S - 55KA4/B4	G

(: mm)

A

SF1252

SF1252	(kg)
	0.75

B

SF1253

SF1253	(kg)
	1.37

C

HF3040 - TM, HF3050A - TM, HF3060A - TMA, HF3080A - TMA, HF3100A - TMA
 <HF3040A - TM, HF3050A - TM, HF3060A - TMA> <HF3080A - TMA, HF3100A - TMA>

	(mm)											(kg)	
	A	B	C	D	E	F	G	H	J	K	L	M	
HF - 3040A - TM	260	210	85	155	140	125	44	140	70	R3.24	M5	M4	5.5
HF - 3050A - TM	290	240	100	190	175	160	44	170	100	8	M6	M4	6.7
HF - 3060A - TMA	290	240	100	190	175	160	44	230	160		M6	M4	10.0
HF - 3080A - TMA	405	350	100	220	200	180	56	210	135	R4.25	M8	M6	13.0
HF - 3100A - TMA										12			14.5

서보앰프
MR-J2S-350A/B/CP/CL이하
MR-J2S-40A1/B1/CP1/CL1이하

1. AC230V L3 L1 · L2
MR - J2S - 70 AC230V
100-200V L3
가

서보앰프
MR-J2S-500A/B/CP/CL
MR-J2S-700A/B/CP/CL
MR-J2S-11KA/B~22KA/B

전원 삼상 AC230V

73

	(: mm)									
D	<p>HF3200A - TMA</p> <p>EMC 가</p> <table border="1"> <thead> <tr> <th></th> <th>(kg)</th> </tr> </thead> <tbody> <tr> <td>HF3200A - TMA</td> <td>23.5</td> </tr> </tbody> </table>		(kg)	HF3200A - TMA	23.5					
	(kg)									
HF3200A - TMA	23.5									
E	<p>TF3005C - TX, TF3020C - TX, TF3030C - TX,</p> <table border="1"> <thead> <tr> <th></th> <th>(kg)</th> </tr> </thead> <tbody> <tr> <td>TF3005C - TX</td> <td>6</td> </tr> <tr> <td>TF3020C - TX</td> <td>6</td> </tr> <tr> <td>TF3030C - TX</td> <td>7.5</td> </tr> </tbody> </table>		(kg)	TF3005C - TX	6	TF3020C - TX	6	TF3030C - TX	7.5	
	(kg)									
TF3005C - TX	6									
TF3020C - TX	6									
TF3030C - TX	7.5									
F	<p>TF3040C - TX, TF3060C - TX</p> <table border="1"> <thead> <tr> <th></th> <th>(kg)</th> </tr> </thead> <tbody> <tr> <td>TF3040C - TX</td> <td>12.5</td> </tr> <tr> <td>TF3060C - TX</td> <td>12.5</td> </tr> </tbody> </table>		(kg)	TF3040C - TX	12.5	TF3060C - TX	12.5			
	(kg)									
TF3040C - TX	12.5									
TF3060C - TX	12.5									
G	<p>TF3150C - TX</p> <table border="1"> <thead> <tr> <th></th> <th>(kg)</th> </tr> </thead> <tbody> <tr> <td>TF3150C - TX</td> <td>31</td> </tr> </tbody> </table>		(kg)	TF3150C - TX	31					
	(kg)									
TF3150C - TX	31									

MELSERVO J2 Super

<MR Configurator (- MRZJW3-SETUP1 (10) >

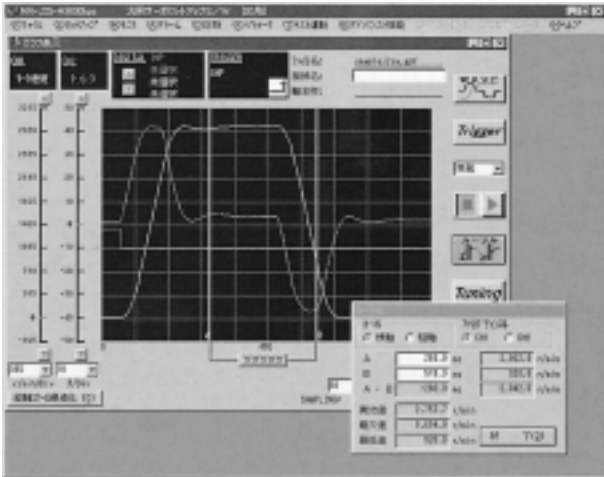

- (1) Windows 95, Windows 98, Windows 98 Second Edition, Windows Me, Windows NT Workstation 4.0, Windows 2000 Professional, Windows XP Professional, Windows XP Home Edition (1,2)
- (2)
- (3)

(1,8)	Windows 95, Windows 98, Windows 98 Second Edition, Windows Me, Windows NT Workstation 4.0, Windows 2000 Professional, Windows XP Professional, Windows XP Home Edition IBM PC/AT : Pentium 133MHz (Windows 95, Windows 98, Windows 98 Second Edition, Windows NT Workstation 4.0, Windows 2000 Professional), Pentium 150MHz (Windows Me) Pentium 300MHz (Windows XP Professional/Home Edition) : 16MB (Windows 95), 24MB (Windows 98, Windows 98 Second Edition) 32MB (Windows Me, Windows NT Workstation 4.0, Windows 2000 Professional) 128MB (Windows XP Professional/Home Edition) : 40MB
OS (10)	Windows 95, Windows 98, Windows 98 Second Edition, Windows Me, Windows NT Workstation 4.0, Windows 2000 Professional, Windows XP Professional, Windows XP Home Edition (2)
	800 x 600 , High Color(16) 가가
	가
	가
	가
	MR - CPCATCBL3M

() MR - J2S

	DI/DO (7), ON , S/W (5)
	ABS , VC (3), () , (5)
	(7)
	JOG , DO , 1 (4), (6)
	(4)
(6)	

- 1. Windows, Windows NT Microsoft Corporation 가
- 2. Windows XP MRZJW3-SETUP161
- 3. VC - MR - J2S - A
- 4. MR - J2S - CP
- 5. -
- 6. MR - J2S - CL
- 7. MR - J2S - CP MR - J2S - CL
- 8. 가 가
- 9. 가
- 10. MR Configurator(-)MRZJW3-SETUP111 MR - J2S - B , MRZJW3-SETUP121 MR - J2S - 500 /MR - J2S - 700 , MRZJW3-SETUP111~SETUP131 Windows 95, Windows 98 . MRZJW3-SETUP151 MR - J2S - CP



MR-J2S-10A/B/CP/CL, 20A/B/CP/CL, 10A1/B1/CP1/CL1, 20A1/B1/CP1/CL1 (1)

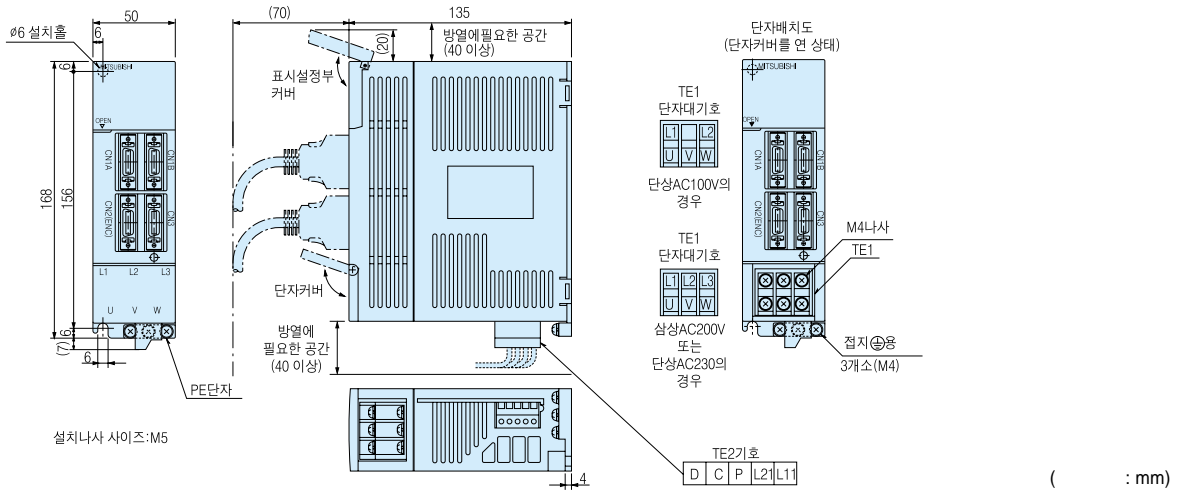

MR-J2S-40A/B/CP/CL, 60A/B/CP/CL, 40A1/B1/CP1/CL1 (1)

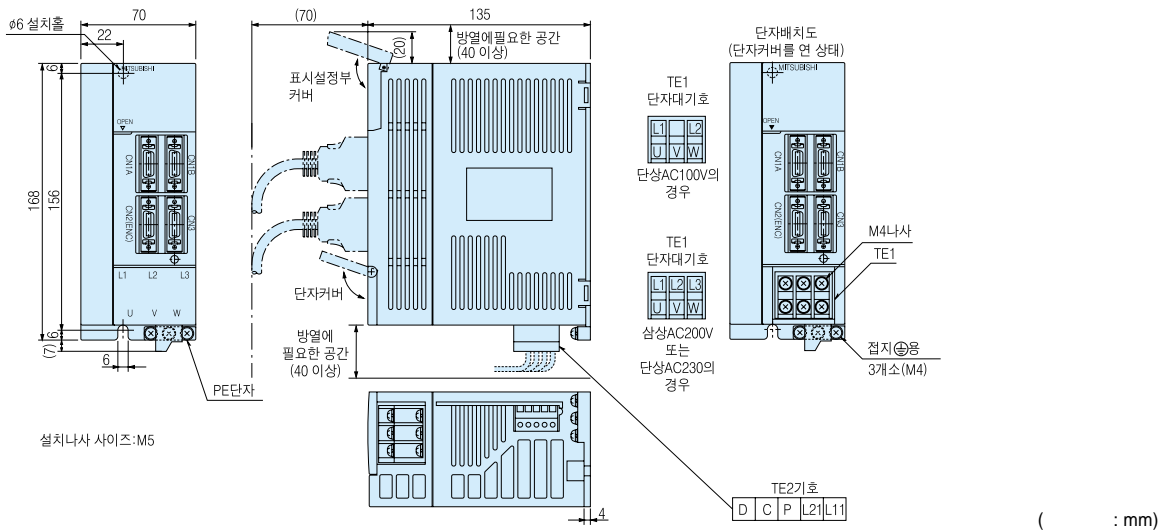

MR-J2S-70A/B/CP/CL(-U), 100A/B/CP/CL (1)

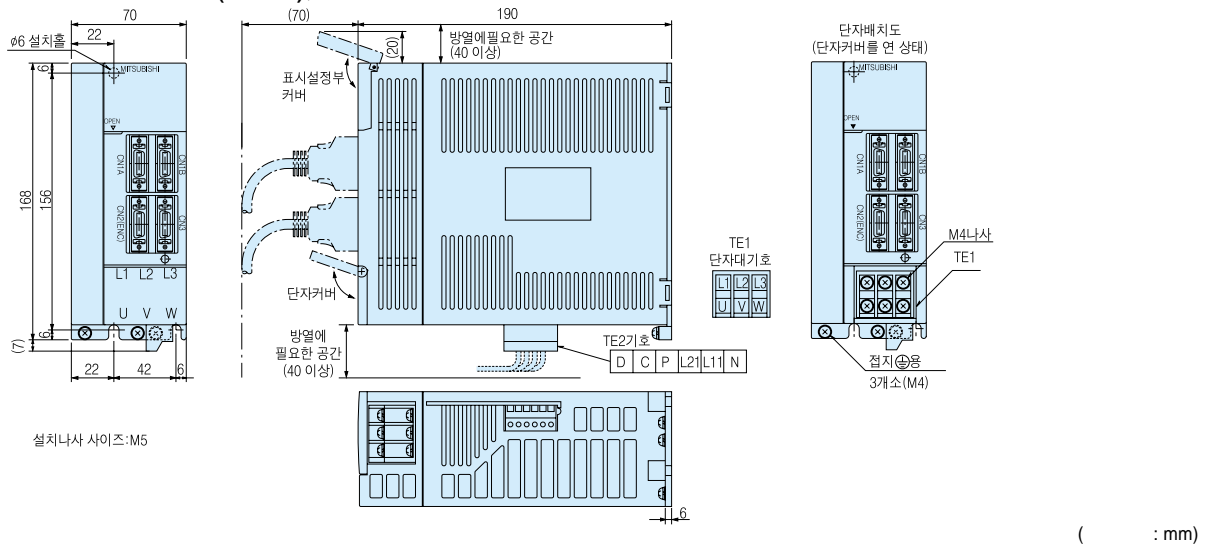

) 1. MR-J2S- CP(1)-S084 MR-J2S- CP(1)

MR-J2S-200A/B/CP/CL, 350A/B/CP/CL (1)

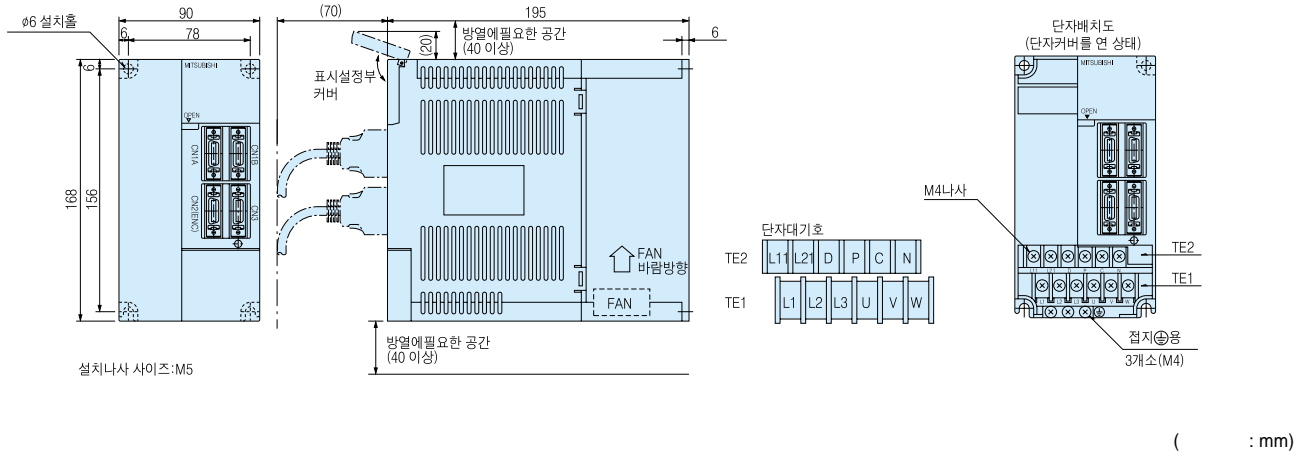

MR-J2S-500A/B/CP/CL (1), 350A4/B4, 500A4/B4

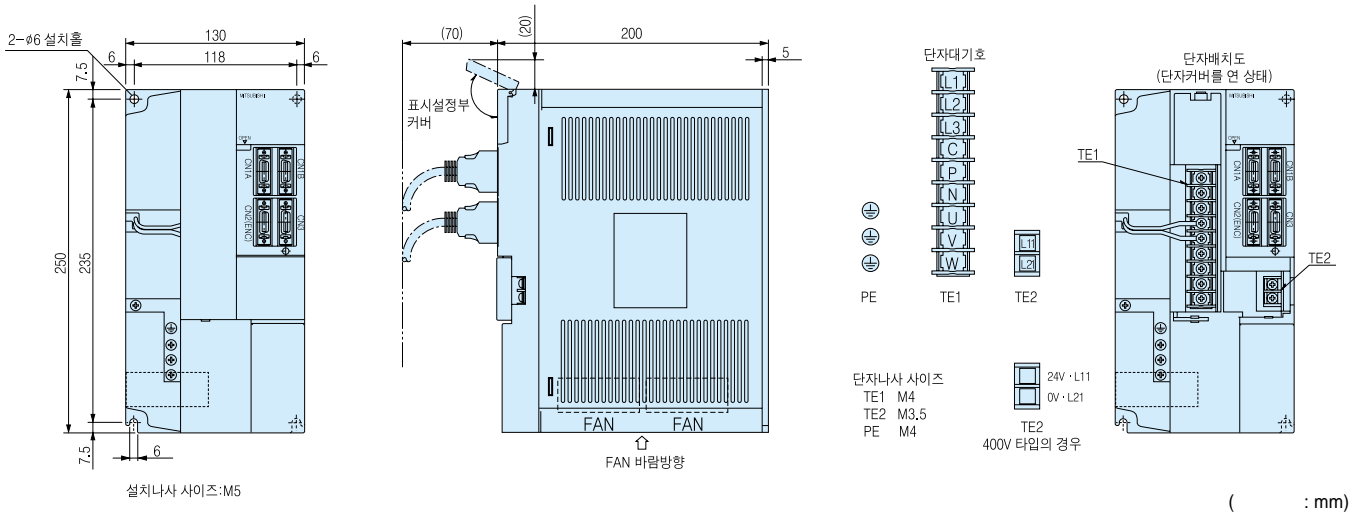

MR-J2S-700A/B/CP/CL (1), 700A4/B4

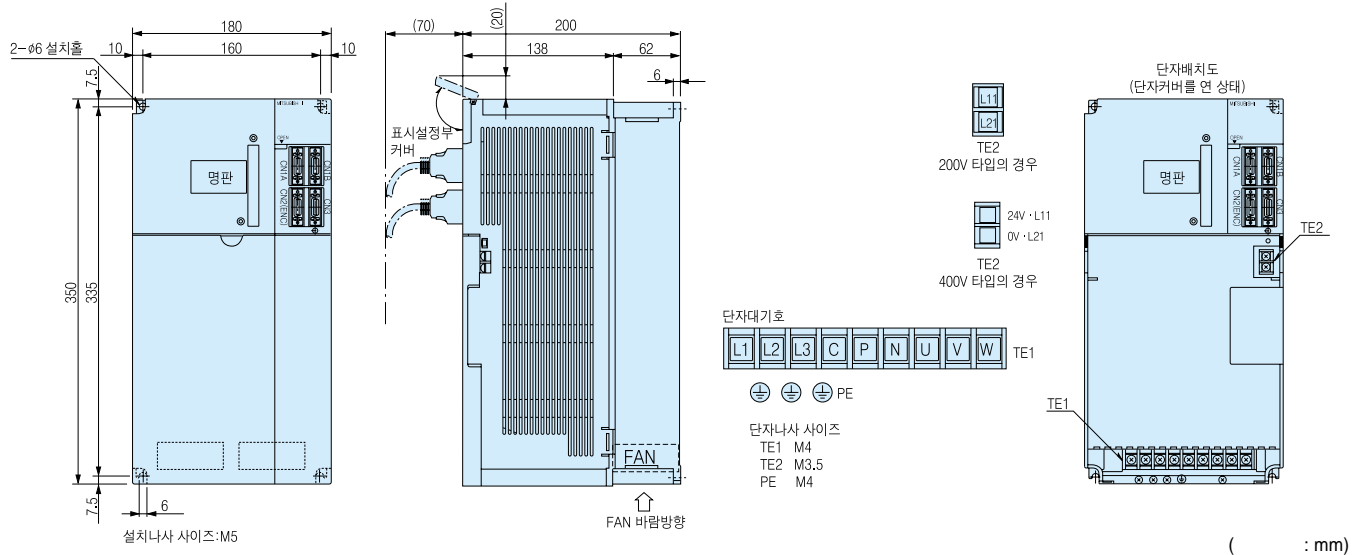

) 1. MR-J2S- CP(1)-S084 MR-J2S- CP(1)

MR-J2S-11KA/B, 15KA/B, 22KA/B, 11KA4/B4, 15KA4/B4, 22KA4/B4

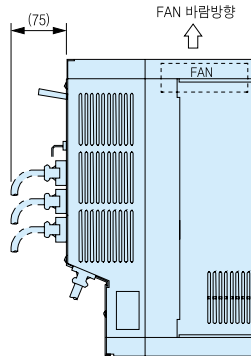
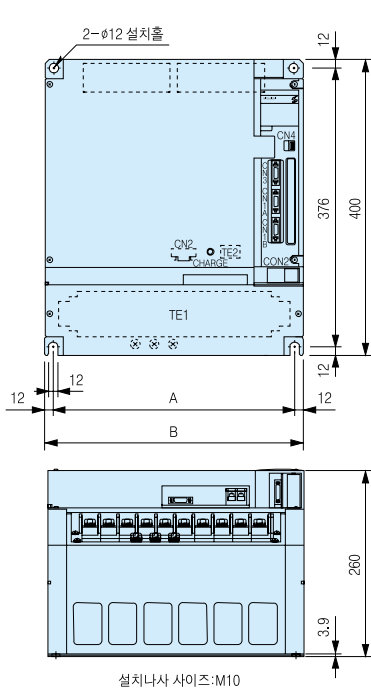

단자대배열

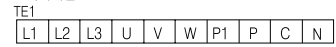

나사사이즈 : M6(MR-J2S-11KA(4)/B(4), 15KA(4)/B(4)의 경우)
나사사이즈 : M8(MR-J2S-22KA(4)/B(4)의 경우)

TE2



나사사이즈 : M4

PE단자

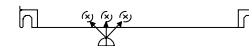

나사사이즈 : M6(MR-J2S-11KA(4)/B(4), 15KA(4)/B(4)의 경우)
나사사이즈 : M8(MR-J2S-22KA(4)/B(4)의 경우)

	A	B
MR - J2S - 11KA/B	236	260
MR - J2S - 15KA/B		
MR - J2S - 11KA4/B4		
MR - J2S - 15KA4/B4	326	350
MR - J2S - 22KA/B		
MR - J2S - 22KA4/B4		

(: mm)

MR-J2S-60A4/B4, 100A4/B4, 200A4/B4

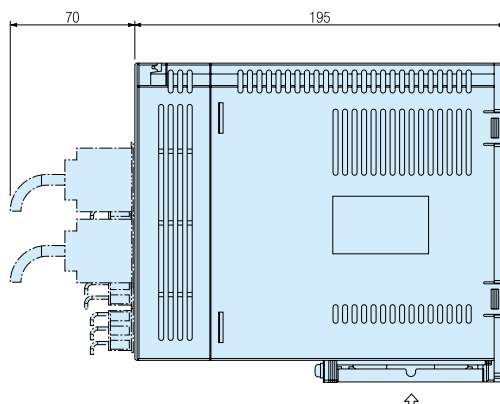
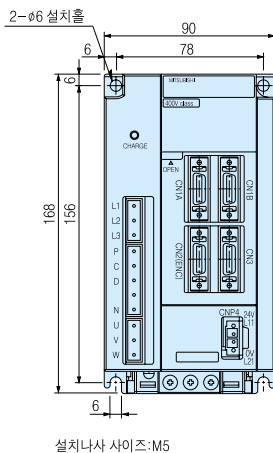

단자대배열

CNP1



CNP2



CNP3



CNP4



CNP1, CNP2, CNP3, CNP4

(: mm)

MR - J2S - 30KA/B, 37KA/B, 30KA4/B4~55KA4/B4

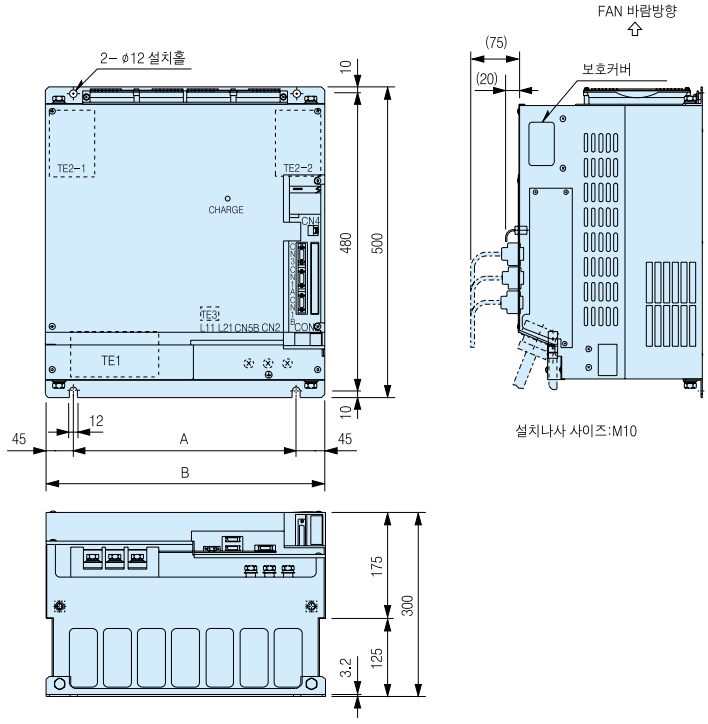

- 단자대배열
TE1
U V W 나사사이즈 : M10
- TE3
L11 L21 나사사이즈 : M3
- TE2
TE2-1
TE2-2
P N 나사사이즈 : M10
- ⊕ 나사사이즈 : M10

	A	B
MR - J2S - 30KA4/B4	290	380
MR - J2S - 30KA/B MR - J2S - 37KA/B MR - J2S - 37KA4/B4 MR - J2S - 45KA4/B4 MR - J2S - 55KA4/B4	360	450

(: mm)

MR-HP30KA, MR-HP55KA4

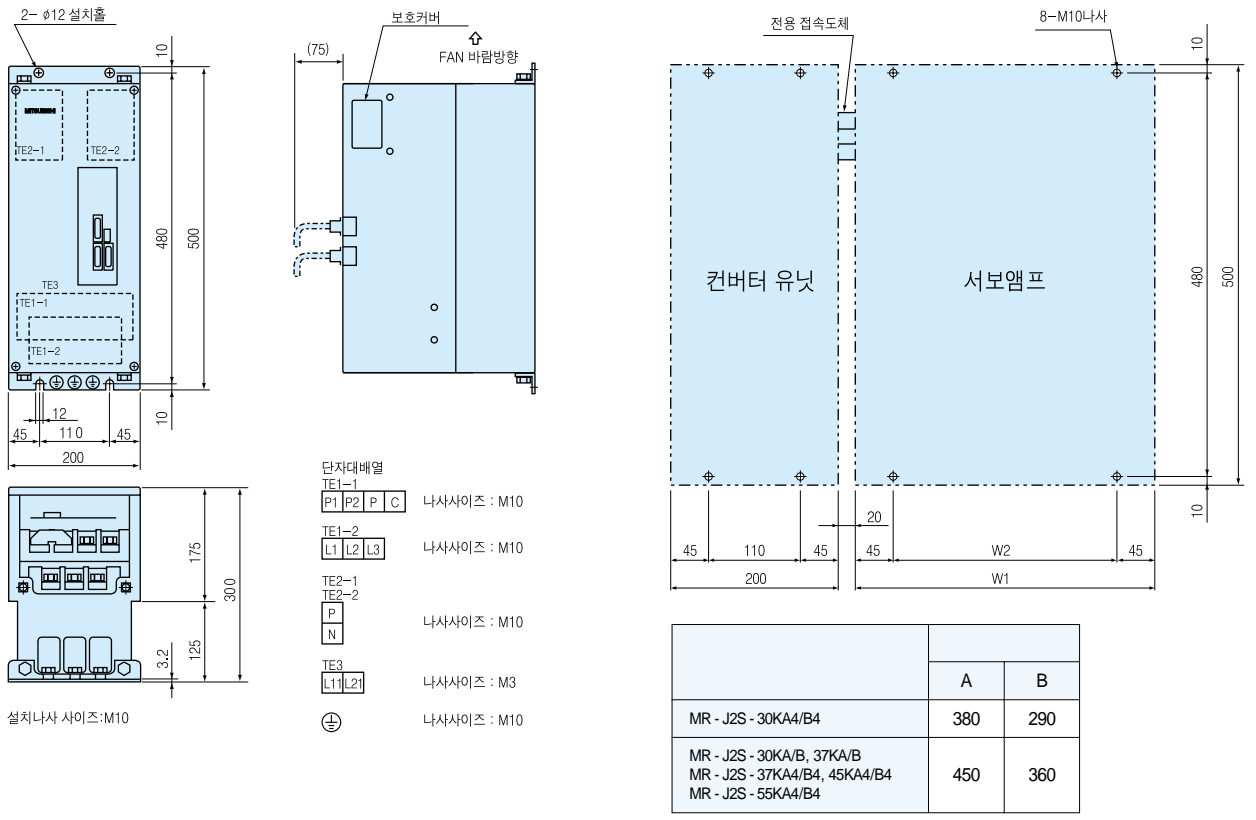

- 단자대배열
TE1-1
P1 P2 P C 나사사이즈 : M10
- TE1-2
L1 L2 L3 나사사이즈 : M10
- TE2-1
TE2-2
P N 나사사이즈 : M10
- TE3
L1 L21 나사사이즈 : M3
- ⊕ 나사사이즈 : M10

	A	B
MR - J2S - 30KA4/B4	380	290
MR - J2S - 30KA/B, 37KA/B MR - J2S - 37KA4/B4, 45KA4/B4 MR - J2S - 55KA4/B4	450	360

(: mm)

(: mm)

HC-KFS053(B), HC-KFS13(B) HC-MFS053(B), HC-MFS13(B)

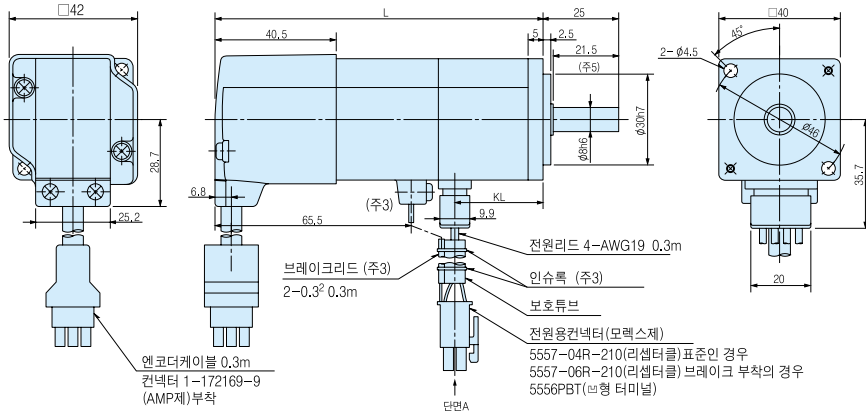

<표준인 경우>

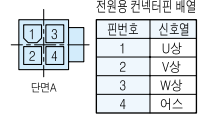

<브레이크를 부착한 경우>



	L	KL
HC - KFS053(B) HC - MFS053(B)	81.5(109.5)	29.5
HC - KFS13(B) HC - MFS13(B)	96.5(124.5)	44.5

(: mm)

HC-KFS23(B), HC-KFS43(B) HC-MFS23(B), HC-MFS43(B)

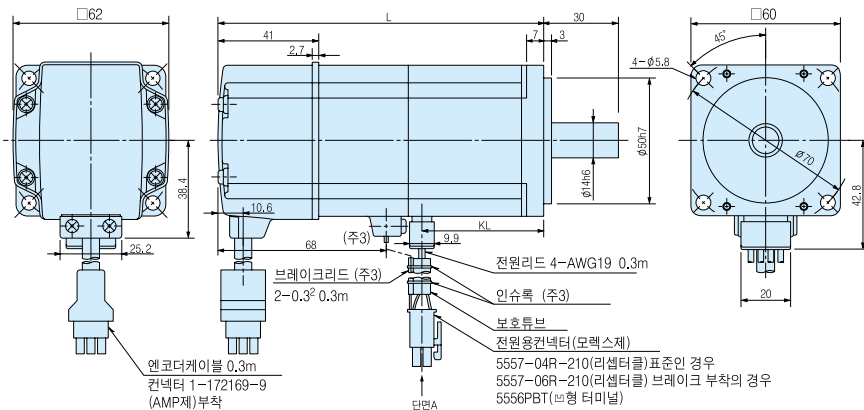

<표준인 경우>

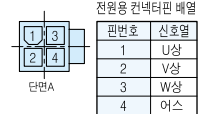

<브레이크를 부착한 경우>

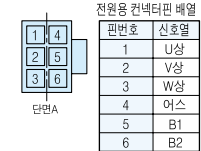

	L	KL
HC - KFS23(B) HC - MFS23(B)	99.5(131.5)	49.1
HC - KFS43(B) HC - MFS43(B)	124.5(156.5)	72.1

(: mm)

MC-KFS73(B), HC-MFS73(B)

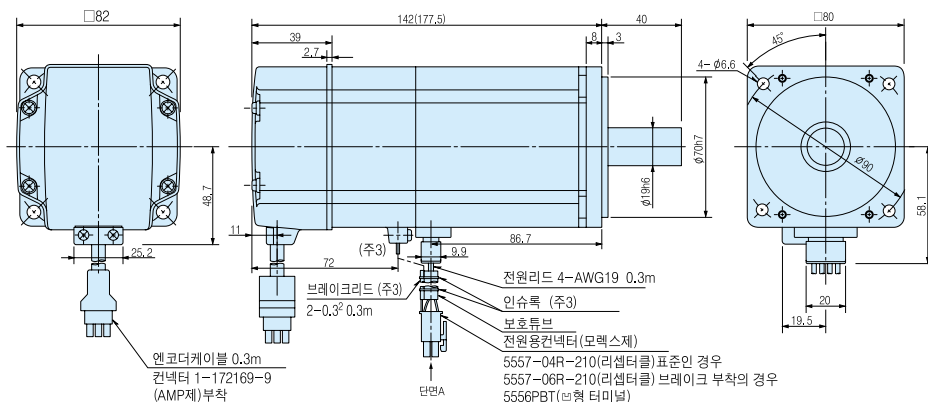

<표준인 경우>

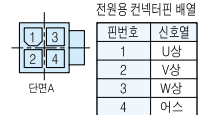

<브레이크를 부착한 경우>



(: mm)

1. ()
2. ()
3. ()
4. 가
5. HC - KFS053(B), KFS13(B)

HC-KFS053(B)G1(1/5, 1/12, 1/20) HC-MFS053(B)G1(1/5, 1/12, 1/20)

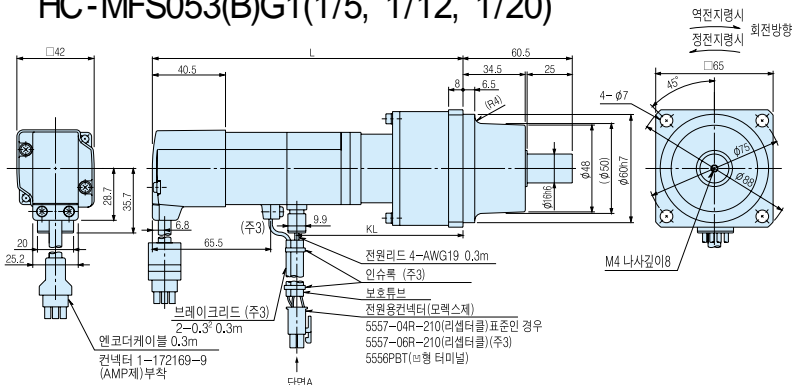

<표준인 경우>

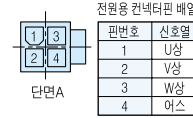

<브레이크를 부착한 경우>

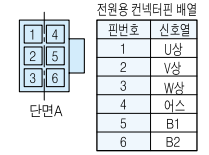

	()	J (x 10 ⁻⁴ kg · m ²)		L	KL	(kg)
		HC-KFS053(B)G1	HC-MFS053(B)G1			
HC-KFS053(B)G1	1/5 <9/44>	0.090 (0.093)	0.055 (0.058)	126 (154)	74	1.4 (1.8)
	1/12 <49/576>	0.112 (0.115)	0.077 (0.080)	144 (172)	92	1.8 (2.2)
HC-MFS053(B)G1	1/20 <25/484>	0.094 (0.097)	0.059 (0.062)	144 (172)	92	1.8 (2.2)

(: mm)

HC-KFS13(B)G1(1/5, 1/12, 1/20) HC-MFS13(B)G1(1/5, 1/12, 1/20)

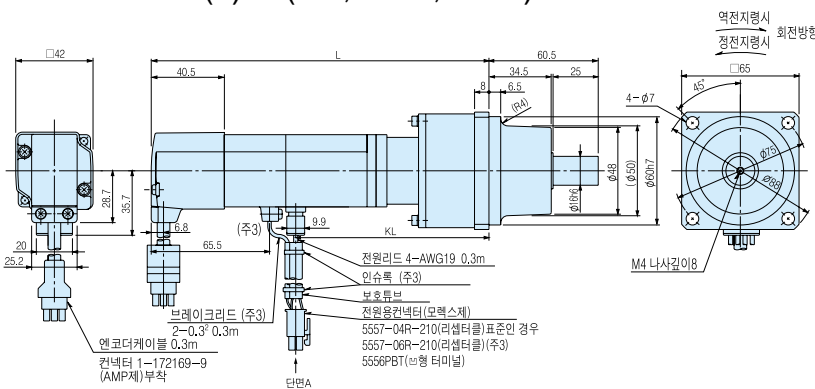

<표준인 경우>

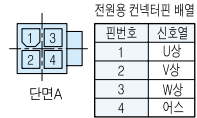

<브레이크를 부착한 경우>

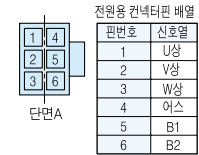

	()	J (x 10 ⁻⁴ kg · m ²)		L	KL	(kg)
		HC-KFS13(B)G1	HC-MFS13(B)G1			
HC-KFS13(B)G1	1/5 <9/44>	0.121 (0.124)	0.067 (0.069)	141 (169)	89	1.5 (1.9)
	1/12 <49/576>	0.143 (0.146)	0.089 (0.091)	159 (187)	107	1.9 (2.3)
HC-MFS13(B)G1	1/20 <25/484>	0.125 (0.128)	0.071 (0.073)	159 (187)	107	1.9 (2.3)

(: mm)

HC-KFS23(B)G1(1/5, 1/12, 1/20) HC-MFS23(B)G1(1/5, 1/12, 1/20)

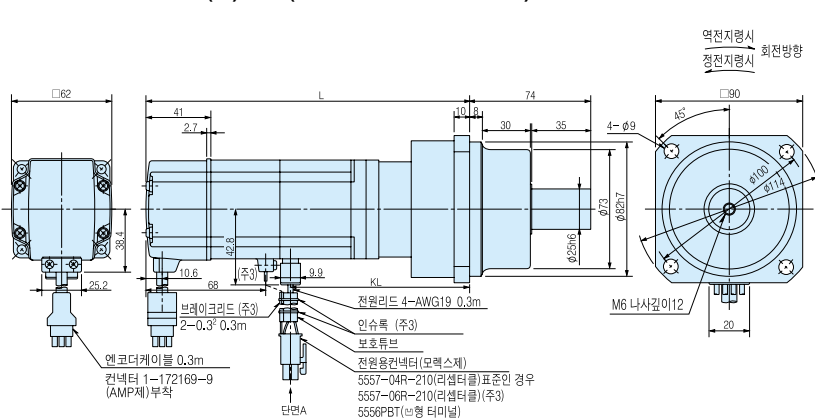

<표준인 경우>



<브레이크를 부착한 경우>

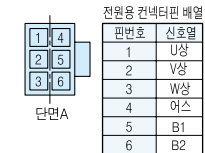

	()	J (x 10 ⁻⁴ kg · m ²)		L	KL	(kg)
		HC-KFS23(B)G1	HC-MFS23(B)G1			
HC-KFS23(B)G1	1/5 <19/96>	0.420 (0.470)	0.249 (0.289)	153 (185)	102.6	3.3 (3.9)
	1/12 <25/288>	0.470 (0.520)	0.293 (0.333)	173 (205)	122.6	3.9 (4.5)
HC-MFS23(B)G1	1/20 <253/5000>	0.440 (0.490)	0.266 (0.306)	173 (205)	122.6	3.9 (4.5)

(: mm)

1. ()
2. ()
- 3.
4. (+)
5. 가

가

1-3mm

가

HC-KFS43(B)G1(1/5, 1/12) HC-MFS43(B)G1(1/5, 1/12)

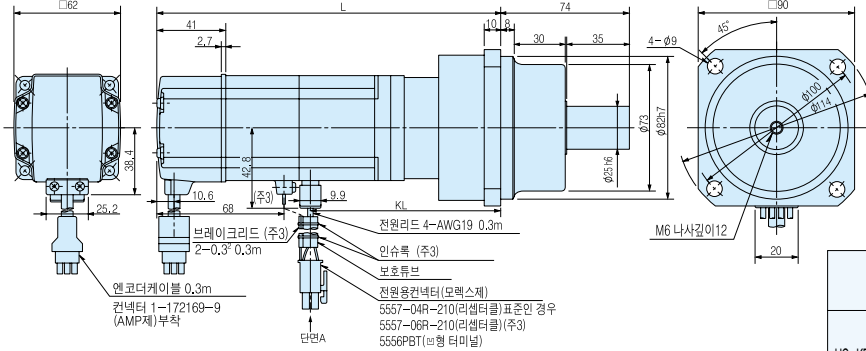

<표준인 경우>

전원용 컨넥터핀 배열	
핀번호	신호열
1	U상
2	V상
3	W상
4	어스

<브레이크를 부착한 경우>

전원용 컨넥터핀 배열	
핀번호	신호열
1	U상
2	V상
3	W상
4	어스
5	B1
6	B2

	()	J (× 10 ⁻⁴ kg · m ²)				(kg)
		HC-KFS43(B)G1	HC-MFS43(B)G1	L	KL	
HC-KFS43(B)G1	1/5 <19/96>	0.610 (0.660)	0.296 (0.344)	178 (210)	125.6	3.8 (4.4)
HC-MFS43(B)G1	1/12 <25/288>	0.660 (0.710)	0.339 (0.388)	198 (230)	145.6	4.4 (5.0)

() : mm

HC-KFS43(B)G1(1/20), HC-KFS73(B)G1(1/5, 1/12, 1/20) HC-MFS43(B)G1(1/20), HC-MFS73(B)G1(1/5, 1/12, 1/20)

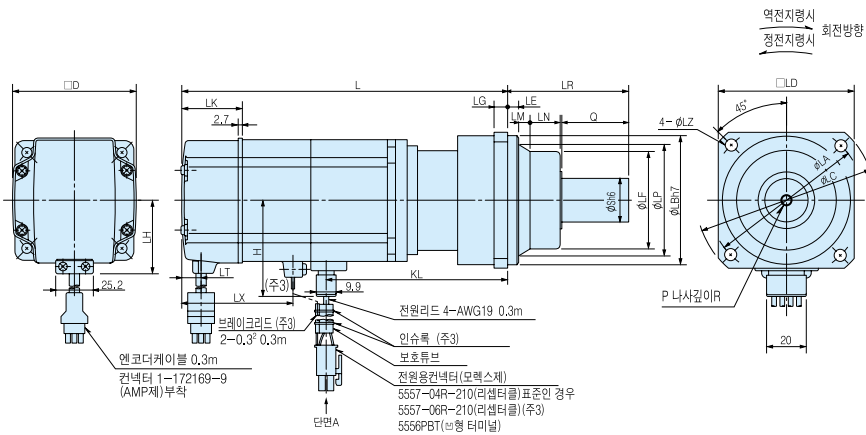

<표준인 경우>

전원용 컨넥터핀 배열	
핀번호	신호열
1	U상
2	V상
3	W상
4	어스

<브레이크를 부착한 경우>

전원용 컨넥터핀 배열	
핀번호	신호열
1	U상
2	V상
3	W상
4	어스
5	B1
6	B2

	()	253/5000	J (× 10 ⁻⁴ kg · m ²)		D LH LK LT LX H LA LB LC LD LE LF LG LM LN LP																L	KL	LR	LZ	Q	S	P	R	(kg)
			HC-KFS43(B)G1	HC-MFS43(B)G1																									
HC-KFS43(B)G1	1/20	0.970 (1.02)	0.653 (0.700)	62	38.4	41	10.6	68	42.8	115	95	132	100	10	10	73	10	13	16	86	201.5(233.5)	149.1	90	9	50	32	M8	16	5.5(6.1)

	()	525/6048	625/12544	J (× 10 ⁻⁴ kg · m ²)		D LH LK LT LX H LA LB LC LD LE LF LG LM LN LP																L	KL	LR	LZ	Q	S	P	R	(kg)
				HC-KFS73(B)G1	HC-MFS73(B)G1																									
HC-KFS73(B)G1	1/5	1.930(2.055)	1.02(1.145)	82	48.7	39	11	72	58.1	115	95	132	100	10	73	10	13	16	86	207(242.5)	151.7	90	9	50	32	M8	16	6.2(7.2)		
HC-MFS73(B)G1	1/12	2.596(2.721)	1.686(1.811)	82	48.7	39	11	72	58.1	115	95	132	100	10	73	10	13	16	86	229(264.5)	173.7	90	9	50	32	M8	16	7.3(8.3)		
	1/20	2.660(2.785)	1.75(1.875)	82	48.7	39	11	72	58.1	140	115	162	120	12	90	15	13	20	104	242(277.5)	186.7	106	14	60	40	M10	20	10.1(11.1)		

() : mm

1. ()
2. ()
- 3.
4. (+)
5. 가 가 1~3mm 가

HC-KFS053(B)G2(1/5, 1/9, 1/20, 1/29)

HC-MFS053(B)G2(1/5, 1/9, 1/20, 1/29)

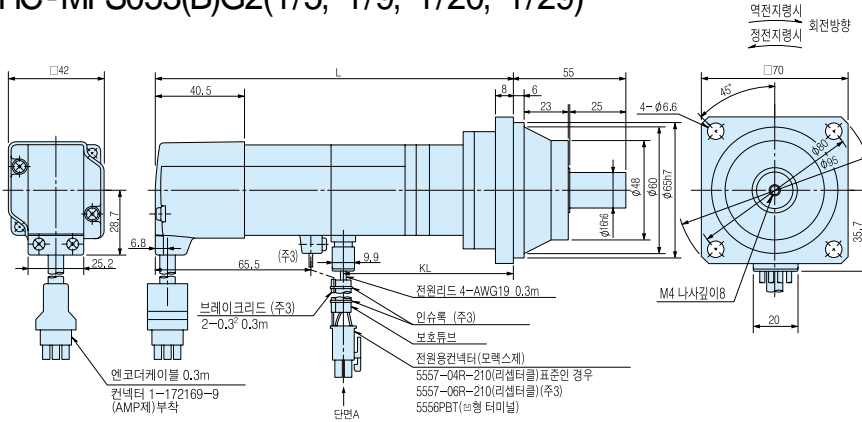

<표준인 경우>

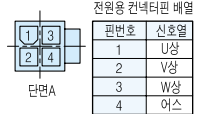

<브레이크를 부착한 경우>

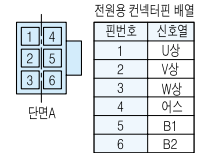

	()	J (x 10 ⁻⁴ kg · m ²)		L	KL	(kg)
		HC-KFS053(B)G2	HC-MFS053(B)G2			
HC-KFS053(B)G2	1/5	0.101(0.104)	0.067(0.07)	130(158)	78	1.4(1.8)
	1/9	0.095(0.098)	0.060(0.063)	146(174)	94	1.7(2.1)
	1/20	0.104(0.107)	0.069(0.072)	146(174)	94	1.8(2.2)
HC-MFS053(B)G2	1/29	0.092(0.095)	0.057(0.060)	146(174)	94	1.8(2.2)

(: mm)

HC-KFS13(B)G2(1/5, 1/9, 1/20, 1/29)

HC-MFS13(B)G2(1/5, 1/9, 1/20, 1/29)

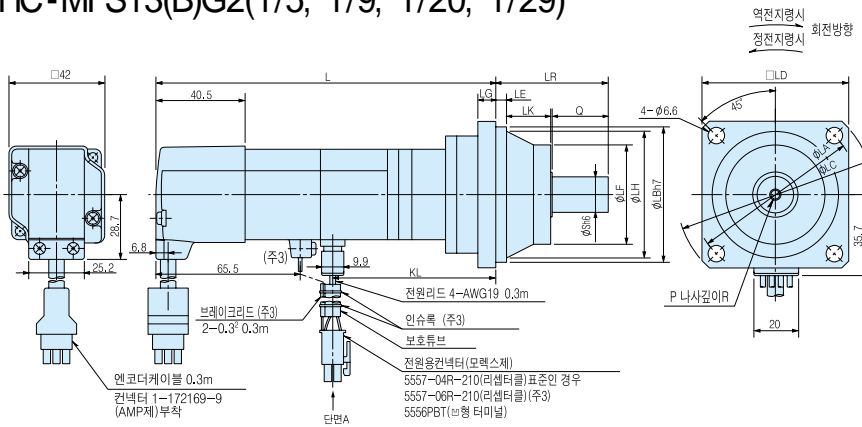

<표준인 경우>

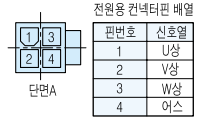

<브레이크를 부착한 경우>

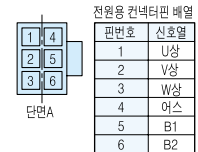

	()	J (x 10 ⁻⁴ kg · m ²)																	(kg)		
		HC-KFS13(B)G2	HC-MFS13(B)G2	LA	LB	LC	LD	LE	LF	LG	LH	LK	L	KL	LR	Q	S	P		R	
HC-KFS13(B)G2	1/5	0.132(0.135)	0.078(0.080)	80	65	95	70	6	48	8	60	23	145 (173)	93	55	25				8	1.5(1.9)
	1/9	0.126(0.129)	0.072(0.074)	80	65	95	70	6	48	8	60	23	161 (189)	109	55	25	16	M4			1.8(2.2)
HC-MFS13(B)G2	1/20	0.176(0.179)	0.122(0.124)	100	80	115	85	6	65	10	74	33	167 (195)	115	75	35				10	3.0(3.4)
	1/29	0.150(0.153)	0.096(0.098)	100	80	115	85	6	65	10	74	33	167 (195)	115	75	35	20	M5			3.0(3.4)

(: mm)

1. ()

2. ()

3.

4.

5. 가 (+)

가 1-3mm

가

HC-KFS23(B)G2(1/5, 1/9, 1/20, 1/29) HC-MFS23(B)G2(1/5, 1/9, 1/20, 1/29)

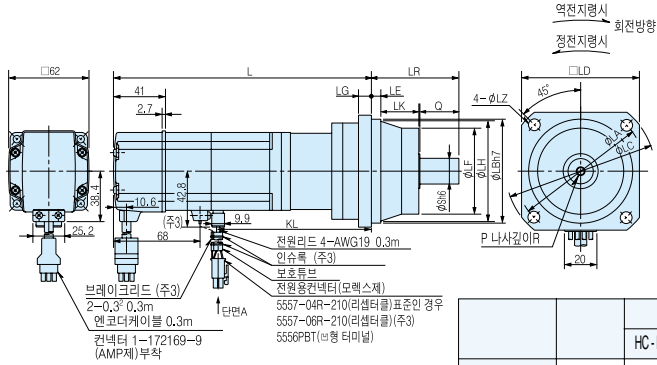

<표준인 경우>

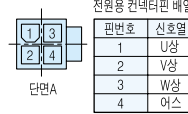

<브레이크를 부착한 경우>



(: mm)

		J (x 10 ⁻⁴ kg · m ²)																(kg)			
		HC-KFS23(B)G2	HC-MFS23(B)G2	LA	LB	LC	LD	LE	LF	LG	LH	LK	L	KL	LR	LZ	Q		S	P	R
HC-KFS23(B)G2	1/5	0.360(0.410)	0.191(0.239)	80	65	95	70	6	48	8	60	23	157 (189)	106.6	55	6.6	25	16	M4	8	2.1(2.7)
	1/9	0.380(0.430)	0.208(0.256)	100	80	115	85	6	65	10	74	33	175 (207)	124.6	75	6.6	35	20	M5	10	3.5(4.1)
HC-MFS23(B)G2	1/20	0.530(0.580)	0.357(0.405)	115	95	135	100	8	75	10	85	35	180 (212)	129.6	85	9	40	25	M6	12	5.0(5.6)
	1/29	0.450(0.500)	0.276(0.324)	115	95	135	100	8	75	10	85	35	180 (212)	129.6	85	9	40	25	M6	12	5.0(5.6)

HC-KFS43(B)G2(1/5, 1/9, 1/20, 1/29) HC-MFS43(B)G2(1/5, 1/9, 1/20, 1/29)

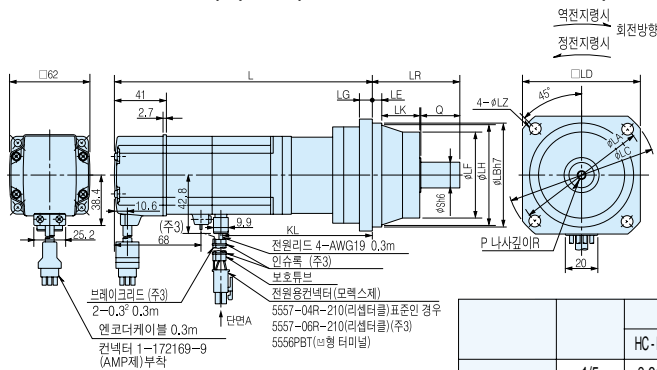

<표준인 경우>

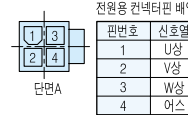

<브레이크를 부착한 경우>

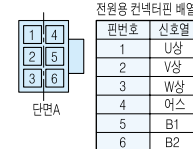

(: mm)

		J (x 10 ⁻⁴ kg · m ²)																(kg)			
		HC-KFS43(B)G2	HC-MFS43(B)G2	LA	LB	LC	LD	LE	LF	LG	LH	LK	L	KL	LR	LZ	Q		S	P	R
HC-KFS43(B)G2	1/5	0.610(0.660)	0.295(0.344)	100	80	115	85	6	65	10	74	33	184 (216)	131.6	75	6.6	35	20	M5	10	3.7(4.3)
	1/9	0.640(0.690)	0.323(0.372)	115	95	135	100	8	75	10	85	35	205 (237)	152.6	85	9	40	25	M6	12	5.3(5.9)
HC-MFS43(B)G2	1/20	0.740(0.790)	0.426(0.475)	135	110	155	115	8	90	12	100	40	211 (243)	158.6	100	11	50	32	M8	16	7.5(8.1)
	1/29	0.660(0.710)	0.338(0.386)	135	110	155	115	8	90	12	100	40	211 (243)	158.6	100	11	50	32	M8	16	7.5(8.1)

HC-KFS73(B)G2(1/5, 1/9, 1/20, 1/29) HC-MFS73(B)G2(1/5, 1/9, 1/20, 1/29)

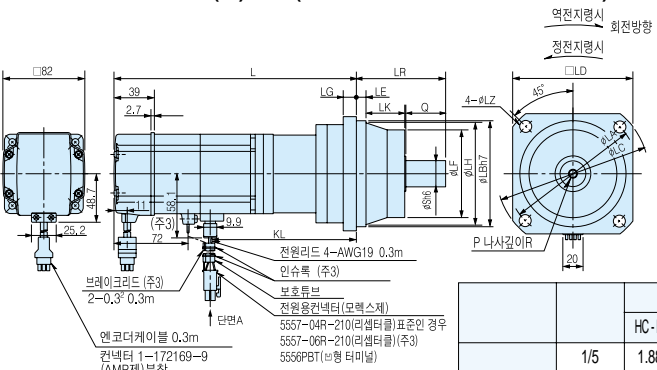

<표준인 경우>



<브레이크를 부착한 경우>

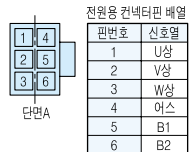

(: mm)

		J (x 10 ⁻⁴ kg · m ²)																(kg)			
		HC-KFS73(B)G2	HC-MFS73(B)G2	LA	LB	LC	LD	LE	LF	LG	LH	LK	L	KL	LR	LZ	Q		S	P	R
HC-KFS73(B)G2	1/5	1.883(2.008)	0.973(1.098)	115	95	135	100	8	75	10	85	35	212 (247.3)	156.7	85	9	40	25	M6	12	6.3(7.3)
	1/9	1.890(2.015)	0.98(1.105)	135	110	155	115	8	90	12	100	40	240 (275.5)	184.7	100	11	50	32	M8	16	8.6(9.6)
HC-MFS73(B)G2	1/20	1.926(2.051)	1.016(1.141)	150	125	175	130	10	105	16	115	43	248 (283.5)	192.7	115	14	60	40	M10	20	12.0(13.0)
	1/29	1.820(1.945)	0.91(1.035)	150	125	175	130	10	105	16	115	43	248 (283.5)	192.7	115	14	60	40	M10	20	12.0(13.0)

1. ()
2. ()
3. ()
4. ()
5. 가 (+)

HC-KFS (B)G5 HC-MFS (B)G5

가

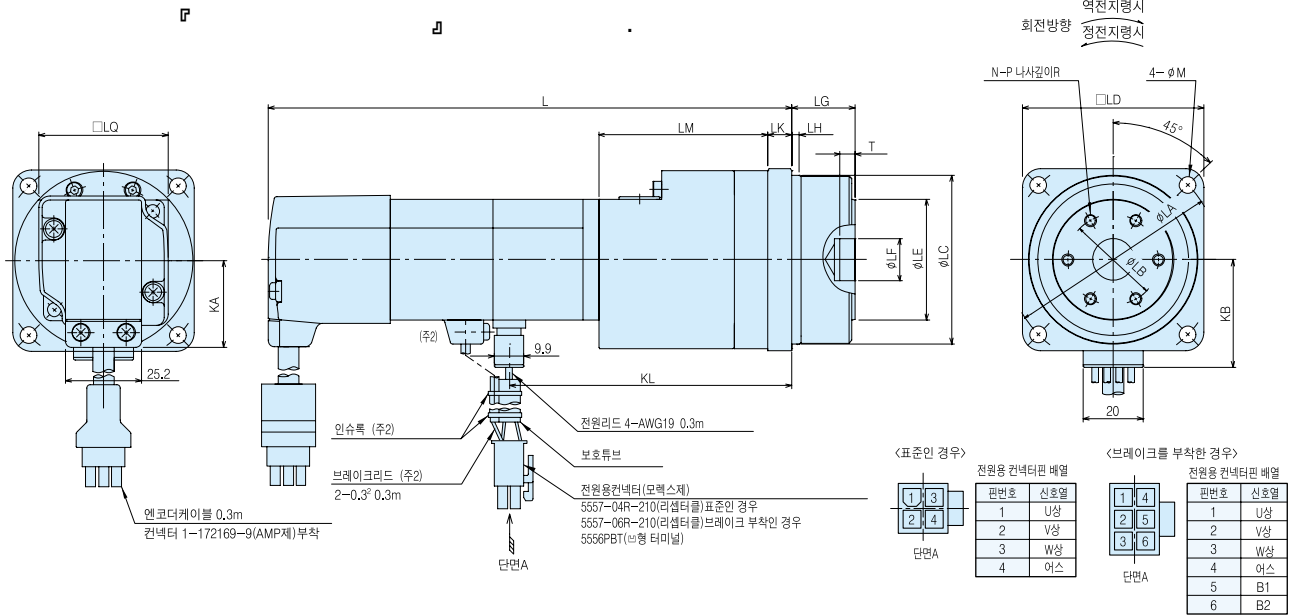

(: mm)

		J (x 10 ⁻⁴ kg · m ²)																		(kg)				
		HC-KFS (B)G5	HC-MFS (B)G5	L	LA	LB	LC	LD	LE	LF	LG	LH	LK	LM	KL	T	N	P	R		M	KA	KB	LQ
HC-KFS053(B)G5 HC-MFS053(B)G5	1/5	0.121 (0.124)	0.087 (0.090)	145.5(173.5)	70	30	56H7	60	40	14H7	21 ^{+0.4} _{-0.5}	3	8	56	93.5	5	6	M4	7	5.5	28.7	35.7	42	1.1(1.5)
	1/11	0.113 (0.116)	0.079 (0.082)																					1.2(1.6)
	1/21	0.104 (0.107)	0.070 (0.073)																					1.3(1.6)
	1/33	0.098 (0.101)	0.064 (0.067)																					1.3(1.7)
	1/45	0.098 (0.101)	0.064 (0.067)																					2.5(2.9)
HC-KFS13(B)G5 HC-MFS13(B)G5	1/5	0.152 (0.155)	0.098 (0.100)	160.5(188.5)	105	45	85H7	90	59	24H7	27 ^{+0.4} _{-0.5}	8	10	56.5	111	5	6	M6	10	9	38.4	42.8	62	1.3(1.6)
	1/11	0.144 (0.147)	0.090 (0.092)																					1.3(1.7)
	1/21	0.135 (0.138)	0.081 (0.083)																					2.5(2.9)
	1/33	0.146 (0.149)	0.092 (0.094)																					3.5(4.1)
	1/45	0.145 (0.148)	0.091 (0.093)																					2.3(2.9)
HC-KFS23(B)G5 HC-MFS23(B)G5	1/5	0.461 (0.511)	0.289 (0.337)	163.5(191)	70	30	56H7	60	40	14H7	21 ^{+0.4} _{-0.5}	3	8	56	113.1	5	6	M4	7	5.5	48.7	58.1	82	1.8(2.4)
	1/11	0.463 (0.513)	0.291 (0.339)																					1.9(2.5)
	1/21	0.758 (0.808)	0.586 (0.634)																					3.5(4.1)
	1/33	0.712 (0.762)	0.540 (0.588)																					2.3(2.9)
	1/45	0.711 (0.761)	0.539 (0.587)																					4.0(4.6)
HC-KFS43(B)G5 HC-MFS43(B)G5	1/5	0.661 (0.711)	0.344 (0.392)	188.5(220.5)	105	45	85H7	90	59	24H7	21 ^{+0.4} _{-0.5}	3	8	56	136.1	5	6	M4	7	5.5	48.7	58.1	82	2.3(2.9)
	1/11	1.04 (1.09)	0.719 (0.767)																					6.1(6.7)
	1/21	0.960 (1.01)	0.641 (0.689)																					4.0(4.6)
	1/33	1.01 (1.06)	0.693 (0.741)																					6.1(6.7)
	1/45	1.00 (1.05)	0.687 (0.735)																					7.4(8.4)
HC-KFS73(B)G5 HC-MFS73(B)G5	1/5	2.16 (2.28)	1.25 (1.37)	220(255.5)	105	45	85H7	90	59	24H7	27 ^{+0.4} _{-0.5}	8	10	68	164.7	5	6	M6	10	9	48.7	58.1	82	5.0(6.0)
	1/11	2.07 (2.19)	1.16 (1.28)																					5.3(6.3)
	1/21	2.26 (2.39)	1.35 (1.48)																					7.4(8.4)
	1/33	2.04 (2.17)	1.13 (1.26)																					7.4(8.4)
	1/45	2.04 (2.16)	1.13 (1.25)																					7.4(8.4)

1. ()
- 2.
- 3.
4. 가

(+)

가

1-3mm

가

HC-KFS (B)G7
HC-MFS (B)G7

가

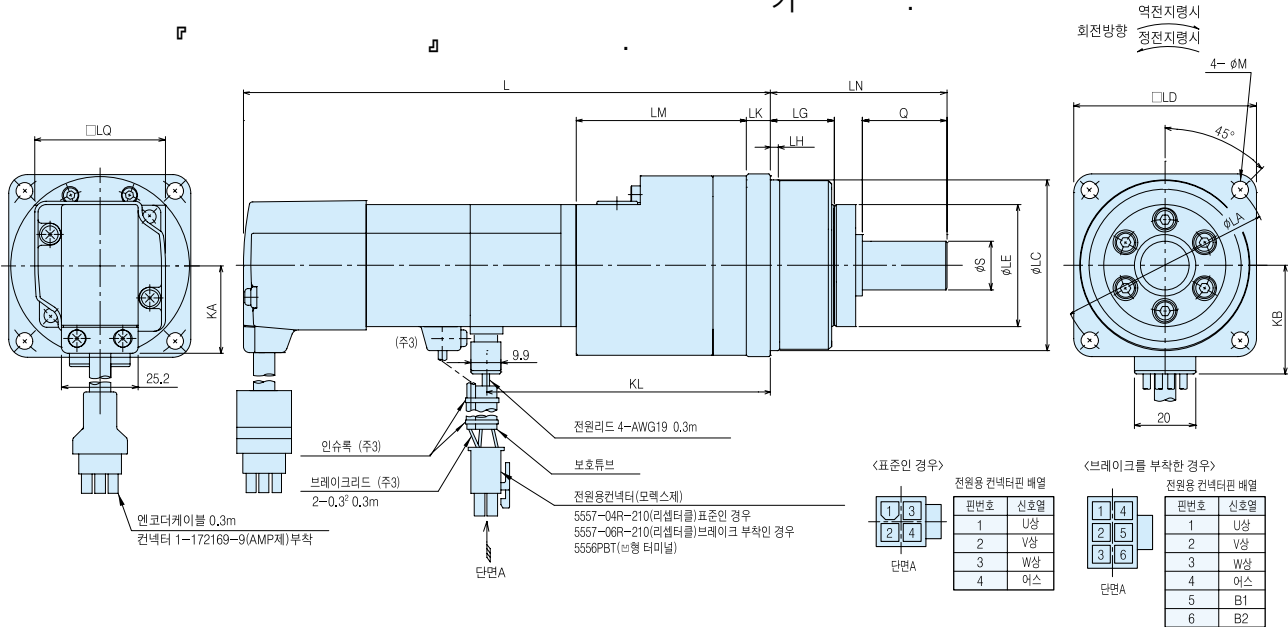

		J(× 10 ⁻⁴ kg · m ²)																		(kg)		
		HC-KFS (B)G5	HC-MFS (B)G7	L	LA	LC	LD	LE	S	LG	LH	Q	LN	LK	LM	KL	M	KA	KB		LQ	
HC - KFS053(B)G7 HC - MFS053(B)G7	1/5	0.127 (0.130)	0.093 (0.096)	145.5(173.5)	70	56h7	60	40	16h7	21	3	28	58	8	56	93.5	5.5	28.7	35.7	42	1.2(1.6)	
	1/11	0.114 (0.117)	0.080 (0.083)																			1.3(1.7)
	1/21	0.104 (0.107)	0.070 (0.073)																			
	1/33	0.098 (0.101)	0.064 (0.067)																			
HC - KFS13(B)G7 HC - MFS13(B)G7	1/45	0.098 (0.101)	0.064 (0.067)	160.5(188.5)	105	85h7	90	59	25h7	27	8	42	80	10	56.5	111	9	28.7	35.7	42	1.4(1.7)	
	1/5	0.158 (0.161)	0.104 (0.106)																			1.4(1.8)
	1/11	0.145 (0.148)	0.091 (0.093)																			
	1/21	0.135 (0.138)	0.081 (0.083)																			
HC - KFS23(B)G7 HC - MFS23(B)G7	1/33	0.147 (0.150)	0.093 (0.095)	163(191)	105	85h7	90	59	25h7	27	8	42	80	10	61	120.1	9	38.4	42.8	62	2.9(3.3)	
	1/45	0.145 (0.148)	0.091 (0.093)																			1.9(2.5)
	1/5	0.467 (0.517)	0.295 (0.343)																			
	1/11	0.463 (0.513)	0.291 (0.339)																			
HC - KFS43(B)G7 HC - MFS43(B)G7	1/21	0.760 (0.810)	0.588 (0.636)	170.5(202.5)	105	85h7	90	59	25h7	27	8	42	80	10	61	120.1	9	38.4	42.8	62	2.0(2.6)	
	1/33	0.713 (0.763)	0.541 (0.589)																			3.9(4.5)
	1/45	0.711 (0.761)	0.539 (0.587)																			
	1/5	0.667 (0.717)	0.350 (0.398)																			
HC - KFS73(B)G7 HC - MFS73(B)G7	1/11	1.04 (1.09)	0.727 (0.775)	188.5(220.5)	105	85h7	90	59	25h7	27	8	42	80	10	61	143.1	9	48.7	58.1	82	2.4(3.0)	
	1/21	0.960 (1.01)	0.643 (0.691)																			4.4(5.0)
	1/33	1.02 (1.07)	0.699 (0.747)																			
	1/45	1.01 (1.06)	0.690 (0.738)																			
HC - KFS73(B)G7 HC - MFS73(B)G7	1/5	2.20 (2.32)	1.29 (1.41)	195.5(227.5)	135	115h7	120	84	40h7	35	13	82	133	13	70	155.1	11	48.7	58.1	82	5.4(6.4)	
	1/11	2.08 (2.20)	1.17 (1.29)																			5.7(6.7)
	1/21	2.28 (2.40)	1.37 (1.49)																			
	1/33	2.05 (2.17)	1.14 (1.26)																			
HC - KFS73(B)G7 HC - MFS73(B)G7	1/45	2.04 (2.17)	1.13 (1.26)	207.5(239.5)	135	115h7	120	84	40h7	35	13	82	133	13	75	174.7	11	48.7	58.1	82	8.8(9.8)	
	1/5	2.20 (2.32)	1.29 (1.41)																			

1. ()
2. ()
3. ()
4. (+)
5. 가

가 , 1-3mm 가

HC-KFS46

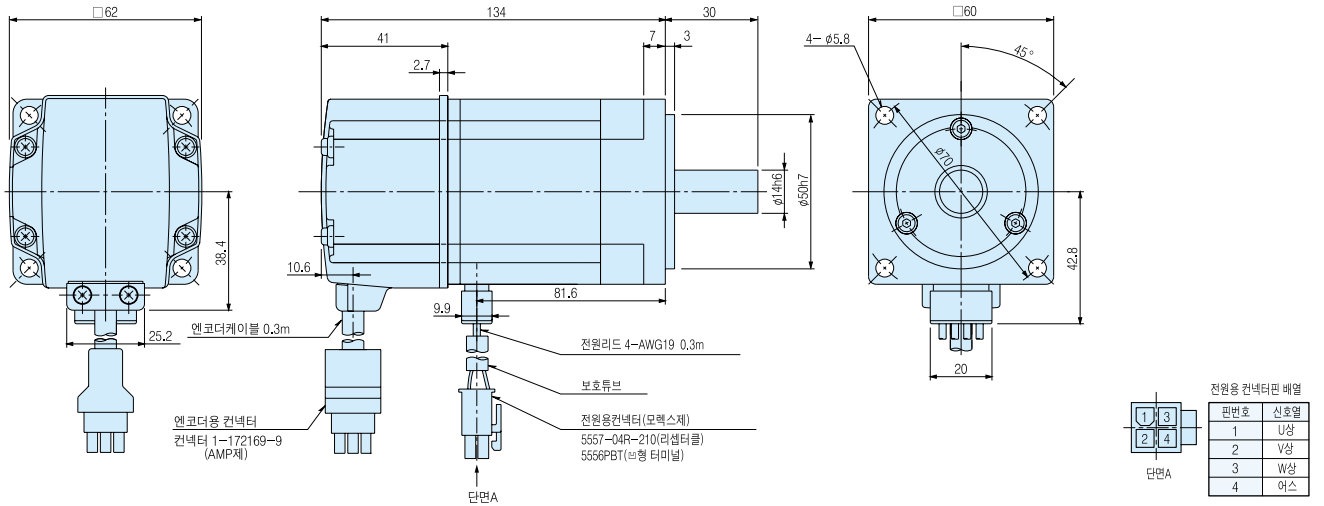

(: mm)

HC-KFS410

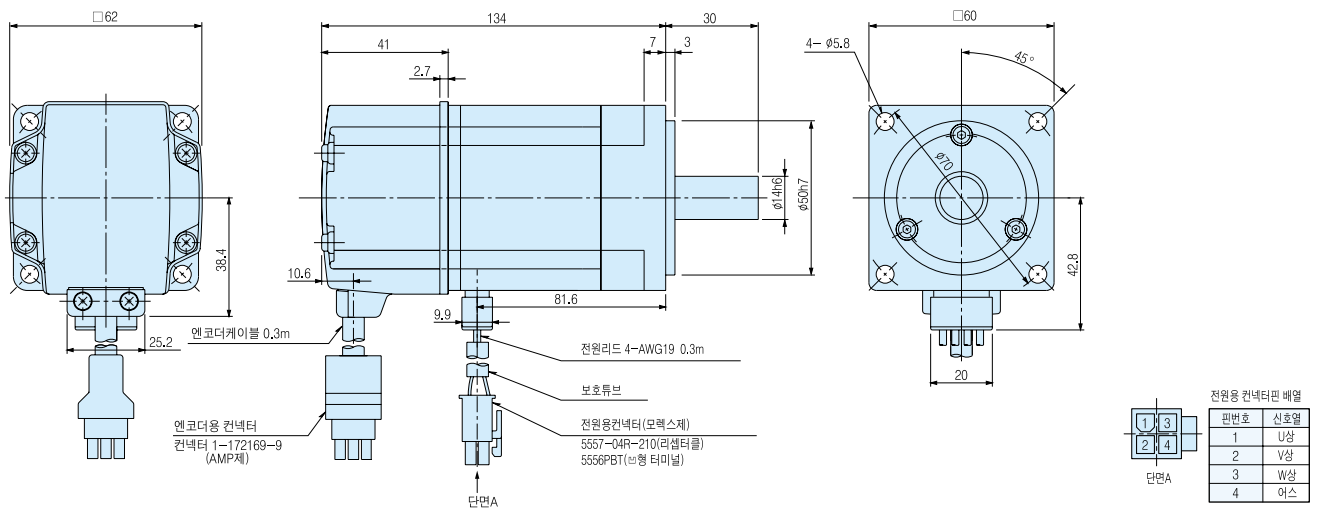

(: mm)

1. ()
2. 가

HC-SFS81(B)
 HC-SFS52(4)(B) ~ HC-SFS152(4)(B)
 HC-SFS53(B) ~ HC-SFS153(B)

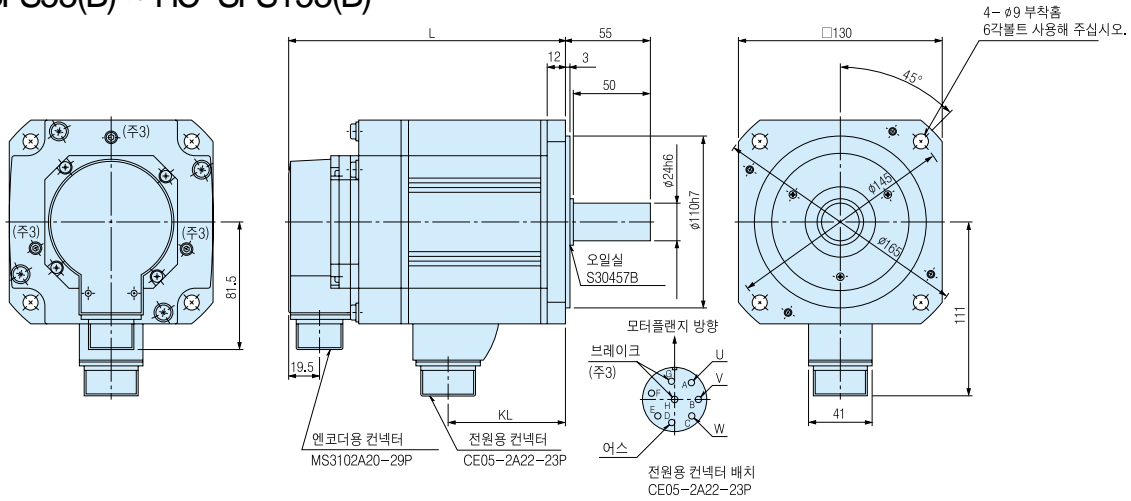

1000r/min	2000r/min	3000r/min	L	KL
-	HC-SFS52(4)(B)	HC-SFS53(B)	120(153)	51.5
-	HC-SFS102(4)(B)	HC-SFS103(B)	145(178)	76.5
HC-SFS81(B)	HC-SFS152(4)(B)	HC-SFS153(B)	170(203)	101.5

(: mm)

HC-SFS121(B) ~ HC-SFS301(B)
 HC-SFS202(4)(B) ~ HC-SFS702(4)(B)
 HC-SFS203(B), HC-SFS353(B)

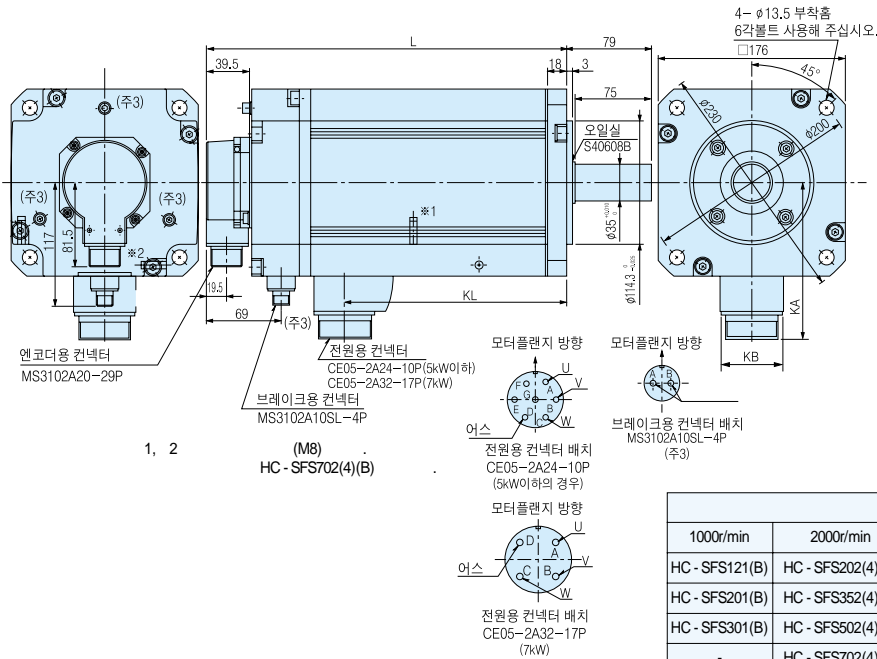

1000r/min	2000r/min	3000r/min	L	KL	KA	KB
HC-SFS121(B)	HC-SFS202(4)(B)	HC-SFS203(B)	145(193)	68.5	142	46
HC-SFS201(B)	HC-SFS352(4)(B)	HC-SFS353(B)	187(235)	110.5	142	46
HC-SFS301(B)	HC-SFS502(4)(B)	-	208(256)	131.5	142	46
-	HC-SFS702(4)(B)	-	292(340)	210.5	150	58

(: mm)

1. () 가
2. () 가
3. 가
4. 가

HC-SFS (B)G1H()

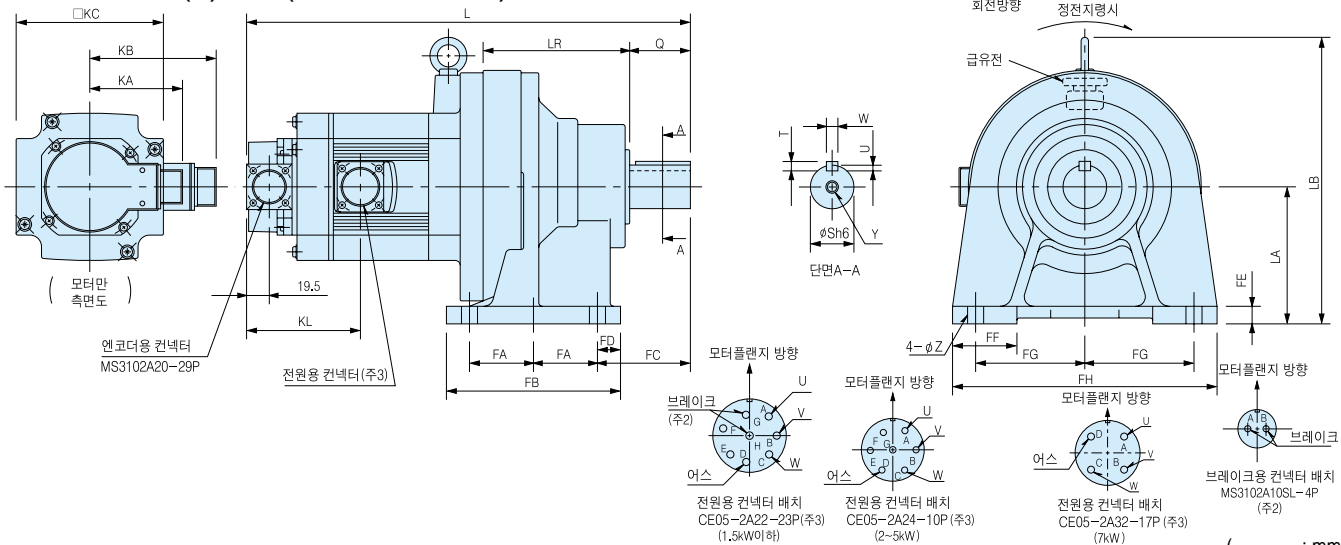

Series	Type	J(x10 ⁻⁴ kg·m ²)	Dimensions (mm)																	Y	(kg)						
			L	LA	LB	LR	KL	KA	KB	KC	Z	FA	FB	FC	FD	FE	FF	FG	FH			Q	S	T	U	W	
HC-SFS52(4)(B)G1H	1/6	7.33 (9.03)	325(358)	100	219	121	68.5(101.5)	81.5	111	130	11	45	135	60	15	12	40	75	180	35	28	7	4	8	-	21(23)	
	1/11	6.95 (8.65)	325(358)	100	219	121	68.5(101.5)	81.5	111	130	11	45	135	60	15	12	40	75	180	35	28	7	4	8	-	21(23)	
	1/17	6.85 (8.55)	325(358)	100	219	121	68.5(101.5)	81.5	111	130	11	45	135	60	15	12	40	75	180	35	28	7	4	8	-	21(23)	
	1/29	6.78 (8.48)	325(358)	100	219	121	68.5(101.5)	81.5	111	130	11	45	135	60	15	12	40	75	180	35	28	7	4	8	-	21(23)	
	1/35	7.5 (9.2)	338(371)	120	252	131	68.5(101.5)	81.5	111	130	14	57.5	155	82	20	15	55	95	230	55	38	8	5	10	-	28(33)	
	1/43	7.45 (9.15)	338(371)	120	252	131	68.5(101.5)	81.5	111	130	14	57.5	155	82	20	15	55	95	230	55	38	8	5	10	-	28(33)	
HC-SFS102(4)(B)G1H	1/59	7.43 (9.13)	338(371)	120	252	131	68.5(101.5)	81.5	111	130	14	57.5	155	82	20	15	55	95	230	55	38	8	5	10	-	28(33)	
	1/6	16.8 (18.5)	363(396)	120	252	131	68.5(101.5)	81.5	111	130	14	57.5	155	82	20	15	55	95	230	55	38	8	5	10	-	30(35)	
	1/11	15.3 (17.0)	363(396)	120	252	131	68.5(101.5)	81.5	111	130	14	57.5	155	82	20	15	55	95	230	55	38	8	5	10	-	30(35)	
	1/17	14.9 (16.6)	363(396)	120	252	131	68.5(101.5)	81.5	111	130	14	57.5	155	82	20	15	55	95	230	55	38	8	5	10	-	30(35)	
	1/29	14.6 (16.3)	363(396)	120	252	131	68.5(101.5)	81.5	111	130	14	57.5	155	82	20	15	55	95	230	55	38	8	5	10	-	30(35)	
	1/35	14.6 (16.3)	363(396)	120	252	131	68.5(101.5)	81.5	111	130	14	57.5	155	82	20	15	55	95	230	55	38	8	5	10	-	30(35)	
HC-SFS152(4)(B)G1H	1/43	15.7 (17.4)	416(449)	150	295	170	68.5(101.5)	81.5	111	130	18	72.5	195	100	25	22	65	145	330	70	50	9	5.5	14	M10	18	51(53)
	1/59	19.5 (21.2)	488(521)	160	352	218	68.5(101.5)	81.5	111	130	18	75	238	139	44	25	75	185	410	90	60	11	7	18	M10	18	90(92)
	1/6	20.8 (22.5)	388(421)	120	252	131	68.5(101.5)	81.5	111	130	14	57.5	155	82	20	15	55	95	230	55	38	8	5	10	-	32(37)	
	1/11	21.5 (23.2)	388(421)	120	252	131	68.5(101.5)	81.5	111	130	14	57.5	155	82	20	15	55	95	230	55	38	8	5	10	-	32(37)	
	1/17	21.2 (22.9)	388(421)	120	252	131	68.5(101.5)	81.5	111	130	14	57.5	155	82	20	15	55	95	230	55	38	8	5	10	-	32(37)	
	1/29	22.1 (23.8)	441(474)	150	295	170	68.5(101.5)	81.5	111	130	18	72.5	195	100	25	22	65	145	330	70	50	9	5.5	14	M10	18	53(55)
HC-SFS202(4)(B)G1H	1/35	22.0 (23.7)	441(474)	150	295	170	68.5(101.5)	81.5	111	130	18	72.5	195	100	25	22	65	145	330	70	50	9	5.5	14	M10	18	53(55)
	1/43	25.8 (27.5)	513(546)	160	352	218	68.5(101.5)	81.5	111	130	18	75	238	139	44	25	75	185	410	90	60	11	7	18	M10	18	92(94)
	1/59	25.7 (27.4)	513(546)	160	352	218	68.5(101.5)	81.5	111	130	18	75	238	139	44	25	75	185	410	90	60	11	7	18	M10	18	92(94)
	1/6	45.6 (55.6)	381(429)	120	262	131	76.5(124.5)	81.5	142	176	14	57.5	155	82	20	15	55	95	230	55	38	8	5	10	-	35(41)	
	1/11	44.1 (54.1)	381(429)	120	262	131	76.5(124.5)	81.5	142	176	14	57.5	155	82	20	15	55	95	230	55	38	8	5	10	-	35(41)	
	1/17	43.7 (53.7)	381(429)	120	262	131	76.5(124.5)	81.5	142	176	14	57.5	155	82	20	15	55	95	230	55	38	8	5	10	-	35(41)	
HC-SFS252(4)(B)G1H	1/29	48.9 (58.9)	498(546)	160	341	218	76.5(124.5)	81.5	142	176	18	75	238	139	44	25	75	185	410	90	60	11	7	18	M10	18	91(97)
	1/35	48.6 (58.6)	498(546)	160	341	218	76.5(124.5)	81.5	142	176	18	75	238	139	44	25	75	185	410	90	60	11	7	18	M10	18	91(97)
	1/43	48.4 (58.4)	498(546)	160	341	218	76.5(124.5)	81.5	142	176	18	75	238	139	44	25	75	185	410	90	60	11	7	18	M10	18	91(97)
	1/59	48.3 (58.3)	498(546)	160	341	218	76.5(124.5)	81.5	142	176	18	75	238	139	44	25	75	185	410	90	60	11	7	18	M10	18	91(97)
	1/6	90.1 (100.1)	473(521)	150	292	170	76.5(124.5)	81.5	142	176	18	72.5	195	100	25	22	65	145	330	70	50	9	5.5	14	M10	18	60(66)
	1/11	86.2 (96.2)	473(521)	150	292	170	76.5(124.5)	81.5	142	176	18	72.5	195	100	25	22	65	145	330	70	50	9	5.5	14	M10	18	60(66)
HC-SFS352(4)(B)G1H	1/17	85.0 (95.0)	473(521)	150	292	170	76.5(124.5)	81.5	142	176	18	72.5	195	100	25	22	65	145	330	70	50	9	5.5	14	M10	18	60(66)
	1/29	88.4 (98.4)	540(588)	160	341	218	76.5(124.5)	81.5	142	176	18	75	238	139	44	25	75	185	410	90	60	11	7	18	M10	18	98(104)
	1/35	88.1 (98.1)	540(588)	160	341	218	76.5(124.5)	81.5	142	176	18	75	238	139	44	25	75	185	410	90	60	11	7	18	M10	18	98(104)
	1/43	106.5 (116.5)	584(632)	200	381	262	76.5(124.5)	81.5	142	176	22	137.5	335	125	30	30	80	190	430	90	70	12	7.5	20	M12	24	139(145)
	1/59	105.9 (115.9)	584(632)	200	381	262	76.5(124.5)	81.5	142	176	22	137.5	335	125	30	30	80	190	430	90	70	12	7.5	20	M12	24	139(145)
	1/11	113.4 (123.4)	561(609)	160	341	218	76.5(124.5)	81.5	142	176	18	75	238	139	44	25	75	185	410	90	60	11	7	18	M10	18	102(108)
HC-SFS502(4)(B)G1H	1/17	109.4 (119.4)	561(609)	160	341	218	76.5(124.5)	81.5	142	176	18	75	238	139	44	25	75	185	410	90	60	11	7	18	M10	18	102(108)
	1/29	138.5 (148.5)	645(693)	220	405	279	76.5(124.5)	81.5	142	176	22	160	380	145	30	85	210	470	110	80	14	9	22	M12	24	171(177)	
	1/35	138 (148)	645(693)	220	405	279	76.5(124.5)	81.5	142	176	22	160	380	145	30	85	210	470	110	80	14	9	22	M12	24	171(177)	
	1/43	137 (147)	645(693)	220	405	279	76.5(124.5)	81.5	142	176	22	160	380	145	30	85	210	470	110	80	14	9	22	M12	24	171(177)	
HC-SFS702(4)(B)G1H	1/11	199 (209)	689(737)	200	381	262	81.5(129.5)	81.5	150	176	22	137.5	335	125	30	80	190	430	90	70	12	7.5	20	M12	24	138(144)	
	1/17	190 (200)	689(737)	200	381	262	81.5(129.5)	81.5	150	176	22	137.5	335	125	30	80	190	430	90	70	12	7.5	20	M12	24	138(144)	
	1/29	197.5 (207.5)	729(777)	220	405	279	81.5(129.5)	81.5	150	176	22	160	380	145	30	85	210	470	110	80	14	9	22	M12	24	180(186)	
	1/35	197 (207)	729(777)	220	405	279	81.5(129.5)	81.5	150	176	22	160	380	145	30	85	210	470	110	80	14	9	22	M12	24	180(186)	
	1/43	257 (267)	820(868)	250	465	330	81.5(129.5)	81.5	150	176	26	190	440	170	30	35	90	240	530	135	95	14	9	25	M20	34	261(267)

1. ()
 2.
 3

HC-SFS (B)G1()

가 가

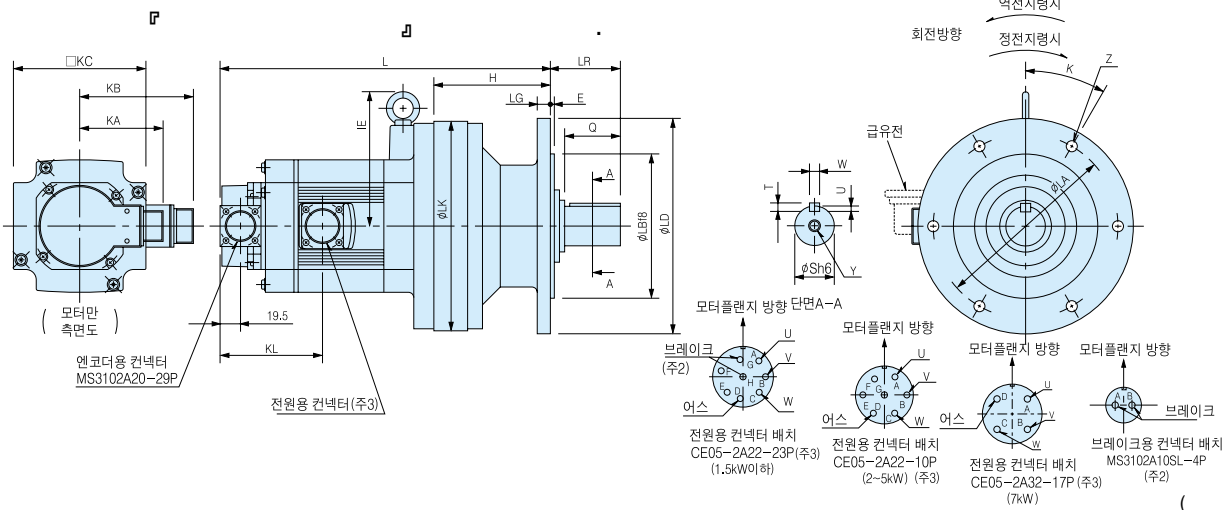

() : mm

Model	Pitch	Inertia J (x 10 ⁻⁴ kg·m ²)	Dimensions (mm)															S	T	U	W	Y	Weight (kg)			
			L	LA	LB	LC	LG	LK	LR	IE	KL	Z	K	E	H	KA	KB							KC	Q	
HC-SFS52(4)(B)G1	1/6	7.33 (9.03)	277(310)	134	110	160	9	150	48	119	68.5(101.5)	4-φ11	45°	3	108	81.5	111	130	35	28	7	4	8	-	18.5(20.5)	
	1/11	6.95 (8.65)	277(310)	134	110	160	9	150	48	119	68.5(101.5)	4-φ11	45°	3	108	81.5	111	130	35	28	7	4	8	-	18.5(20.5)	
	1/17	6.85 (8.55)	277(310)	134	110	160	9	150	48	119	68.5(101.5)	4-φ11	45°	3	108	81.5	111	130	35	28	7	4	8	-	18.5(20.5)	
	1/29	6.78 (8.48)	277(310)	134	110	160	9	150	48	119	68.5(101.5)	4-φ11	45°	3	108	81.5	111	130	35	28	7	4	8	-	18.5(20.5)	
	1/35	7.5 (9.2)	269(302)	180	140	210	13	204	69	132	68.5(101.5)	6-φ11	30°	4	117	81.5	111	130	55	38	8	5	10	-	27(32.5)	
HC-SFS102(4)(B)G1	1/43	7.45 (9.15)	269(302)	180	140	210	13	204	69	132	68.5(101.5)	6-φ11	30°	4	117	81.5	111	130	55	38	8	5	10	-	27(32.5)	
	1/59	7.43 (9.13)	269(302)	180	140	210	13	204	69	132	68.5(101.5)	6-φ11	30°	4	117	81.5	111	130	55	38	8	5	10	-	27(32.5)	
	1/6	16.8 (18.5)	294(327)	180	140	210	13	204	69	132	68.5(101.5)	6-φ11	30°	4	117	81.5	111	130	55	38	8	5	10	-	29(34.5)	
	1/11	15.3 (17.0)	294(327)	180	140	210	13	204	69	132	68.5(101.5)	6-φ11	30°	4	117	81.5	111	130	55	38	8	5	10	-	29(34.5)	
	1/17	14.9 (16.6)	294(327)	180	140	210	13	204	69	132	68.5(101.5)	6-φ11	30°	4	117	81.5	111	130	55	38	8	5	10	-	29(34.5)	
HC-SFS152(4)(B)G1	1/29	14.6 (16.3)	294(327)	180	140	210	13	204	69	132	68.5(101.5)	6-φ11	30°	4	117	81.5	111	130	55	38	8	5	10	-	29(34.5)	
	1/35	14.6 (16.3)	294(327)	180	140	210	13	204	69	132	68.5(101.5)	6-φ11	30°	4	117	81.5	111	130	55	38	8	5	10	-	29(34.5)	
	1/43	15.7 (17.4)	340(373)	230	200	260	15	230	76	145	68.5(101.5)	6-φ11	60°	4	164	81.5	111	130	70	50	9	5.5	14	M10	18	48(50)
	1/59	19.5 (21.2)	399(432)	310	270	340	20	300	89	192	68.5(101.5)	6-φ11	60°	4	219	81.5	111	130	90	60	11	7	18	M10	18	83(85)
	1/6	20.8 (22.5)	319(352)	180	140	210	13	204	69	132	68.5(101.5)	6-φ11	30°	4	117	81.5	111	130	55	38	8	5	10	-	31(36.5)	
HC-SFS202(4)(B)G1	1/11	21.5 (23.2)	319(352)	180	140	210	13	204	69	132	68.5(101.5)	6-φ11	30°	4	117	81.5	111	130	55	38	8	5	10	-	31(36.5)	
	1/17	21.2 (22.9)	319(352)	180	140	210	13	204	69	132	68.5(101.5)	6-φ11	30°	4	117	81.5	111	130	55	38	8	5	10	-	31(36.5)	
	1/29	22.1 (23.8)	365(398)	230	200	260	15	230	76	145	68.5(101.5)	6-φ11	60°	4	164	81.5	111	130	70	50	9	5.5	14	M10	18	50(52)
	1/35	22.0 (23.7)	365(398)	230	200	260	15	230	76	145	68.5(101.5)	6-φ11	60°	4	164	81.5	111	130	70	50	9	5.5	14	M10	18	50(52)
	1/43	25.8 (27.5)	424(457)	310	270	340	20	300	89	192	68.5(101.5)	6-φ11	60°	4	219	81.5	111	130	90	60	11	7	18	M10	18	85(87)
HC-SFS252(4)(B)G1	1/59	25.7 (27.4)	424(457)	310	270	340	20	300	89	192	68.5(101.5)	6-φ11	60°	4	219	81.5	111	130	90	60	11	7	18	M10	18	85(87)
	1/6	45.6 (55.6)	312(360)	180	140	210	13	204	69	142	76.5(124.5)	6-φ11	30°	4	117	81.5	142	176	55	38	8	5	10	-	34(40)	
	1/11	44.1 (54.1)	312(360)	180	140	210	13	204	69	142	76.5(124.5)	6-φ11	30°	4	117	81.5	142	176	55	38	8	5	10	-	34(40)	
	1/17	43.7 (53.7)	312(360)	180	140	210	13	204	69	142	76.5(124.5)	6-φ11	30°	4	117	81.5	142	176	55	38	8	5	10	-	34(40)	
	1/29	48.9 (58.9)	409(457)	310	270	340	20	300	89	181	76.5(124.5)	6-φ11	60°	4	219	81.5	142	176	90	60	11	7	18	M10	18	84(90)
HC-SFS352(4)(B)G1	1/35	48.6 (58.6)	409(457)	310	270	340	20	300	89	181	76.5(124.5)	6-φ11	60°	4	219	81.5	142	176	90	60	11	7	18	M10	18	84(90)
	1/43	48.4 (58.4)	409(457)	310	270	340	20	300	89	181	76.5(124.5)	6-φ11	60°	4	219	81.5	142	176	90	60	11	7	18	M10	18	84(90)
	1/59	48.3 (58.3)	409(457)	310	270	340	20	300	89	181	76.5(124.5)	6-φ11	60°	4	219	81.5	142	176	90	60	11	7	18	M10	18	84(90)
	1/6	90.1 (100.1)	397(445)	230	200	260	15	230	76	142	76.5(124.5)	6-φ11	60°	4	164	81.5	142	176	70	50	9	5.5	14	M10	18	57(63)
	1/11	86.2 (96.2)	397(445)	230	200	260	15	230	76	142	76.5(124.5)	6-φ11	60°	4	164	81.5	142	176	70	50	9	5.5	14	M10	18	57(63)
HC-SFS502(4)(B)G1	1/17	85.0 (95.0)	397(445)	230	200	260	15	230	76	142	76.5(124.5)	6-φ11	60°	4	164	81.5	142	176	70	50	9	5.5	14	M10	18	57(63)
	1/29	88.4 (98.4)	451(499)	310	270	340	20	300	89	181	76.5(124.5)	6-φ11	60°	4	219	81.5	142	176	90	60	11	7	18	M10	18	91(97)
	1/35	88.1 (98.1)	451(499)	310	270	340	20	300	89	181	76.5(124.5)	6-φ11	60°	4	219	81.5	142	176	90	60	11	7	18	M10	18	91(97)
	1/43	106.5 (116.5)	490(538)	360	316	400	22	340	94	181	76.5(124.5)	8-φ14	22.5°	5	258	81.5	142	176	90	70	12	7.5	20	M12	24	133(139)
	1/59	105.9 (115.9)	490(538)	360	316	400	22	340	94	181	76.5(124.5)	8-φ14	22.5°	5	258	81.5	142	176	90	70	12	7.5	20	M12	24	133(139)
HC-SFS702(4)(B)G1	1/11	113.4 (123.4)	472(520)	310	270	340	20	300	89	181	76.5(124.5)	6-φ11	60°	4	219	81.5	142	176	89	60	11	7	18	M10	18	95(101)
	1/17	109.4 (119.4)	472(520)	310	270	340	20	300	89	181	76.5(124.5)	6-φ11	60°	4	219	81.5	142	176	89	60	11	7	18	M10	18	95(101)
	1/29	138.5 (148.5)	535(583)	390	345	430	22	370	110	176	76.5(124.5)	8-φ18	22.5°	5	279	81.5	142	176	105	80	14	9	22	M12	24	162(168)
	1/35	138 (148)	535(583)	390	345	430	22	370	110	176	76.5(124.5)	8-φ18	22.5°	5	279	81.5	142	176	105	80	14	9	22	M12	24	162(168)
	1/43	137 (147)	535(583)	390	345	430	22	370	110	176	76.5(124.5)	8-φ18	22.5°	5	279	81.5	142	176	105	80	14	9	22	M12	24	162(168)
HC-SFS702(4)(B)G1	1/11	199 (209)	595(643)	360	316	400	22	340	94	181	81.5(129.5)	8-φ18	22.5°	5	258	81.5	150	176	90	70	12	7.5	20	M12	24	146(152)
	1/17	190 (200)	595(643)	360	316	400	22	340	94	181	81.5(129.5)	8-φ18	22.5°	5	258	81.5	150	176	90	70	12	7.5	20	M12	24	146(152)
	1/29	197.5 (207.5)	619(667)	390	345	430	22	370	110	176	81.5(129.5)	8-φ18	22.5°	5	279	81.5	150	176	105	80	14	9	22	M12	24	171(177)
	1/35	197 (207)	619(667)	390	345	430	22	370	110	176	81.5(129.5)	8-φ18	22.5°	5	279	81.5	150	176	105	80	14	9	22	M12	24	171(177)
	1/43	257 (267)	675(723)	450	400	490	30	430	145	210	81.5(129.5)	12-φ18	15°	6	320	81.5	150	176	135	95	14	9	25	M20	34	240(246)

1. ()
- 2.
- 3.
4. (+)
5. HC-SFS (B)G1
6. 가

HC-SFS (B)

가 가 1-3mm 가

HC-SFS (B)G2

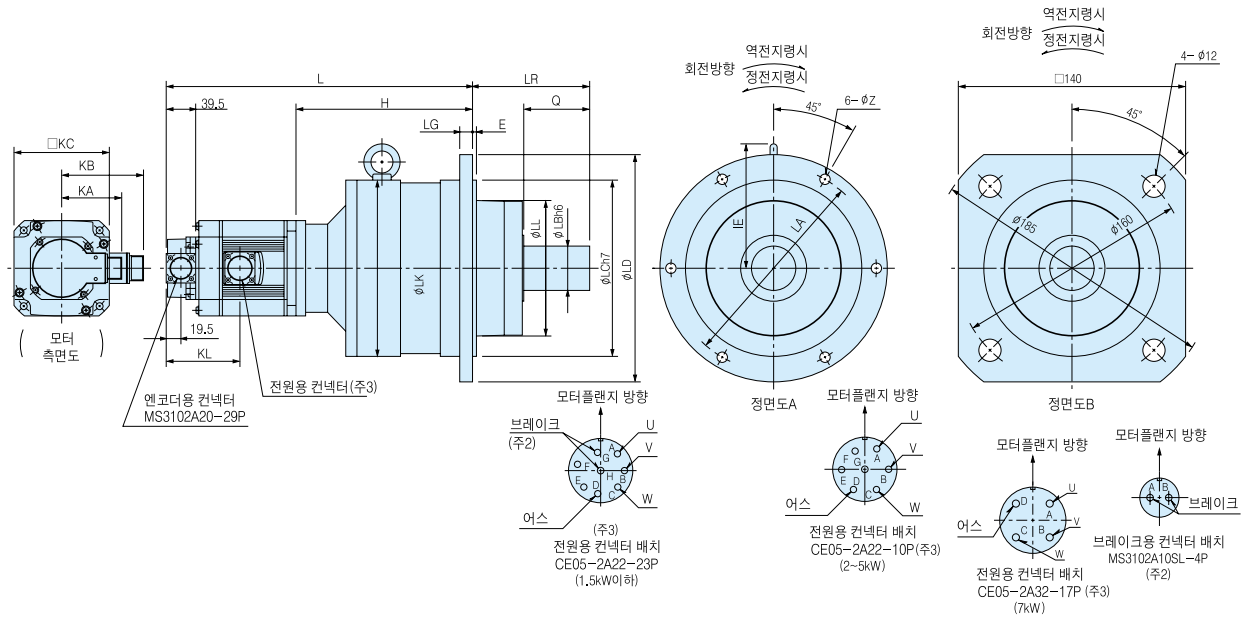

(: mm)

		J (x 10 ⁻⁴ kg · m ²)																		(kg)		
			L	LA	LB	LC	LD	LG	LK	LL	LR	IE	KL	Z	E	H	KA	KB	KC		Q	
HC - SFS52(4)(B)G2	1/5	7.9 (9.6)	276(309)	-	35	130	-	12	132	94	100	-	68.5(101.5)	-	3	156	81.5	111	130	55	B	13(15)
	1/9	7.55 (9.25)	288(321)	-	35	130	-	12	132	94	100	-	68.5(101.5)	-	3	168	81.5	111	130	55	B	13(15)
	1/20	8.03 (9.73)	309(342)	-	35	130	-	12	132	94	100	-	68.5(101.5)	-	3	189	81.5	111	130	55	B	15(17)
	1/29	9.4 (11.1)	337(370)	220	50	190	245	15	190	135	140	137	68.5(101.5)	12	5	217	81.5	111	130	75	A	30(32)
HC - SFS102(4)(B)G2	1/5	15.0 (16.7)	301(334)	-	35	130	-	12	132	94	100	-	68.5(101.5)	-	3	168	81.5	111	130	55	B	15(17)
	1/9	14.6 (16.3)	313(346)	-	35	130	-	12	132	94	100	-	68.5(101.5)	-	3	168	81.5	111	130	55	B	15(17)
	1/20	18.4 (20.1)	362(395)	220	50	190	245	15	190	135	140	137	68.5(101.5)	12	5	217	81.5	111	130	75	A	32(34)
	1/29	16.5 (18.2)	362(395)	220	50	190	245	15	190	135	140	137	68.5(101.5)	12	5	217	81.5	111	130	75	A	32(34)
HC - SFS152(4)(B)G2	1/5	21.2 (22.9)	326(359)	-	35	130	-	12	132	94	100	-	68.5(101.5)	-	3	156	81.5	111	130	55	B	17(19)
	1/9	24.7 (26.4)	379(412)	220	50	190	245	15	190	135	140	137	68.5(101.5)	12	5	209	81.5	111	130	75	A	34(36)
	1/20	24.6 (26.3)	387(420)	220	50	190	245	15	190	135	140	137	68.5(101.5)	12	5	217	81.5	111	130	75	A	34(36)
	1/29	30.3 (32.0)	411(444)	280	60	240	310	18	240	186	160	171	68.5(101.5)	14	5	241	81.5	111	130	90	A	54(56)
HC - SFS202(4)(B)G2	1/5	26.5 (28.2)	414(447)	280	60	240	310	18	240	186	160	171	68.5(101.5)	14	5	244	81.5	111	130	90	A	54(56)
	1/9	49.6 (59.6)	348(396)	220	50	190	245	15	190	135	140	137	76.5(124.5)	12	5	203	81.5	142	176	75	A	30(36)
	1/20	47.2 (57.2)	375(423)	220	50	190	245	15	190	135	140	137	76.5(124.5)	12	5	230	81.5	142	176	75	A	37(43)
	1/29	59.6 (69.6)	407(455)	280	60	240	310	18	240	186	160	171	76.5(124.5)	14	5	262	81.5	142	176	90	A	57(63)
HC - SFS352(4)(B)G2	1/5	52.8 (62.8)	407(455)	280	60	240	310	18	240	186	160	171	76.5(124.5)	14	5	262	81.5	142	176	90	A	57(63)
	1/9	49.1 (59.1)	410(458)	280	60	240	310	18	240	186	160	171	76.5(124.5)	14	5	265	81.5	142	176	90	A	57(63)
	1/20	99.4 (109.4)	410(458)	280	60	240	310	18	240	186	160	171	76.5(124.5)	14	5	223	81.5	142	176	90	A	54(60)
	1/29	91.5 (101.5)	442(490)	280	60	240	310	18	240	186	160	171	76.5(124.5)	14	5	255	81.5	142	176	90	A	64(70)
HC - SFS502(4)(B)G2	1/5	99.1 (109.1)	449(497)	280	60	240	310	18	240	186	160	171	76.5(124.5)	14	5	262	81.5	142	176	90	A	64(70)
	1/9	118.4 (128.4)	431(479)	280	60	240	310	18	240	186	160	171	76.5(124.5)	14	5	223	81.5	142	176	90	A	58(64)
HC - SFS702(4)(B)G2	1/5	110.5 (120.5)	463(511)	280	60	240	310	18	240	186	160	171	76.5(124.5)	14	5	255	81.5	142	176	90	A	68(74)
	1/9	177.4 (187.4)	515(563)	280	60	240	310	18	240	186	160	171	81.5(129.5)	14	5	223	81.5	150	176	90	A	67(73)

1. ()
- 2.
- 3.
- 4.
5. 가

(+)

HC - SFS (B)

가

1~3mm

가

HC-SFS (B)G5

가

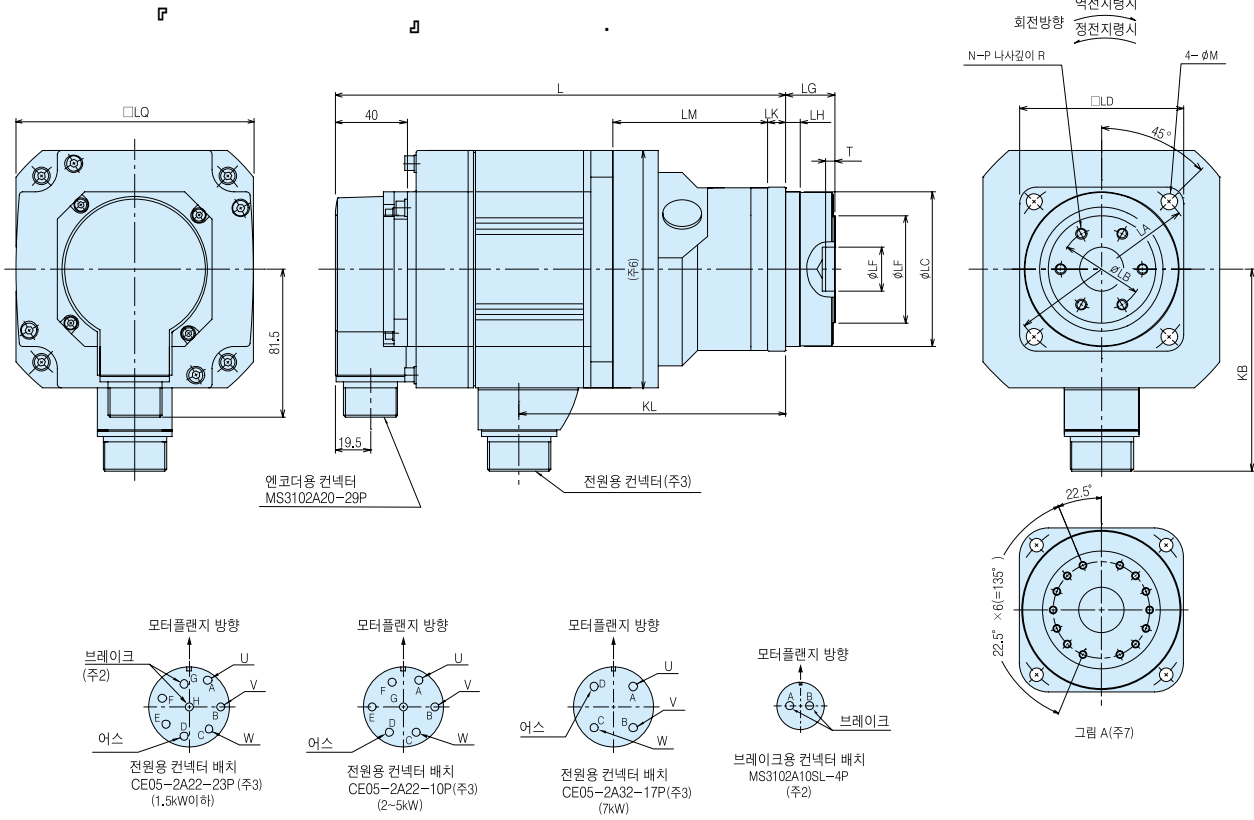

(: mm)

		J (x 10 ⁻⁴ kg · m ²)	가													N	P	R	M	KB	LQ	(kg)									
			L	LA	LB	LC	LD	LE	LF	LG	LH	LK	LM	KL	T																
HC - SFS52(4)(B)G5	1/5	7.25 (9.25)	215(248)	105	45	85h7	90	59	24H7	27 ^{+0.4} _{0.5}	8	10	85	146.5	5	6	M6	10	9	111	130	7.8(9.8)									
	1/11	7.16 (9.16)																											8.0(10.0)		
	1/21	9.50 (11.5)																												11.5(13.5)	
	1/33	9.30 (11.3)	227(260)	135	60	115h7	120	84	32H7	35 ^{+0.4} _{0.5}	13	13	94	158.5										M8	12	11					
	1/45	9.30 (11.3)																													
HC - SFS102(4)(B)G5	1/5	14.4 (16.4)	240(273)	105	45	85h7	90	59	24H7	27 ^{+0.4} _{0.5}	8	10	85	171.5	7	14(7)	M6	10	9	111	130	9.8(11.8)									
	1/11	17.0 (19.0)																												13.5(15.5)	
	1/21	16.6 (18.6)	252(285)	135	60	115h7	120	84	32H7	35 ^{+0.4} _{0.5}	13	13	94	183.5										M8	12	11					
	1/33	18.4 (20.4)																													
	1/45	18.3 (20.3)	268(301)	190	100	165h8	170	122	47H7	53 ^{+0.5} _{0.8}	13	16	107	199.5																	15.5(17.5)
HC - SFS152(4)(B)G5	1/5	20.7 (22.7)	265(298)	105	45	85h7	90	59	24H7	27 ^{+0.4} _{0.5}	8	10	85	196.5	5	6	M6	10	9	111	130	11.8(13.8)									
	1/11	23.3 (25.3)	277(310)	135	60	115h7	120	84	32H7	35 ^{+0.4} _{0.5}	13	13	94	208.5																	
	1/21	25.7 (27.7)																													15.5(17.5)
	1/33	24.7 (26.7)	293(326)	190	100	165h8	170	122	47H7	53 ^{+0.5} _{0.8}	13	16	107	224.5										M6	10	9					
	1/45	24.6 (26.6)																													
HC - SFS202(4)(B)G5	1/5	47.1 (57.1)	274(322)	135	60	115h7	120	84	32H7	35 ^{+0.4} _{0.5}	13	13	116(6)	197.5	5	6	M6	10	9	111	130	19.5(25.5)									
	1/11	46.9 (56.9)																													
	1/21	48.9 (58.9)																													20.0(26.0)
	1/33	47.9 (57.9)	294(342)	190	100	165h8	170	122	47H7	53 ^{+0.5} _{0.8}	13	16	133(6)	217.5										M8	12	14					
	1/45	47.9 (57.9)																													
HC - SFS352(4)(B)G5	1/5	86.6 (96.6)	316(364)	135	60	115h7	120	84	32H7	35 ^{+0.4} _{0.5}	13	13	116(6)	239.5	5	6	M6	10	9	111	130	26.5(32.5)									
	1/11	90.1 (100)																													
	1/21	88.4 (98.4)	336(384)											259.5																	36.1(42.1)
HC - SFS502(4)(B)G5	1/5	111 (121)	357(405)	190	100	165h8	170	122	47H7	53 ^{+0.4} _{0.8}	13	16	133(6)	280.5	7	14(7)	M6	10	9	111	130	38.6(44.6)									
	1/11	109 (119)												280.5																	40.1(46.1)
HC - SFS702(4)(B)G5	1/5	170 (180)	441(489)											359.5									47.6(53.6)								

1. ()
- 2.
3. HC-SFS (B)
4. 가 (+)
5. 가 1~3mm 가
6. LM (6)
7. A 180 가

HC-SFS (B)G7

가

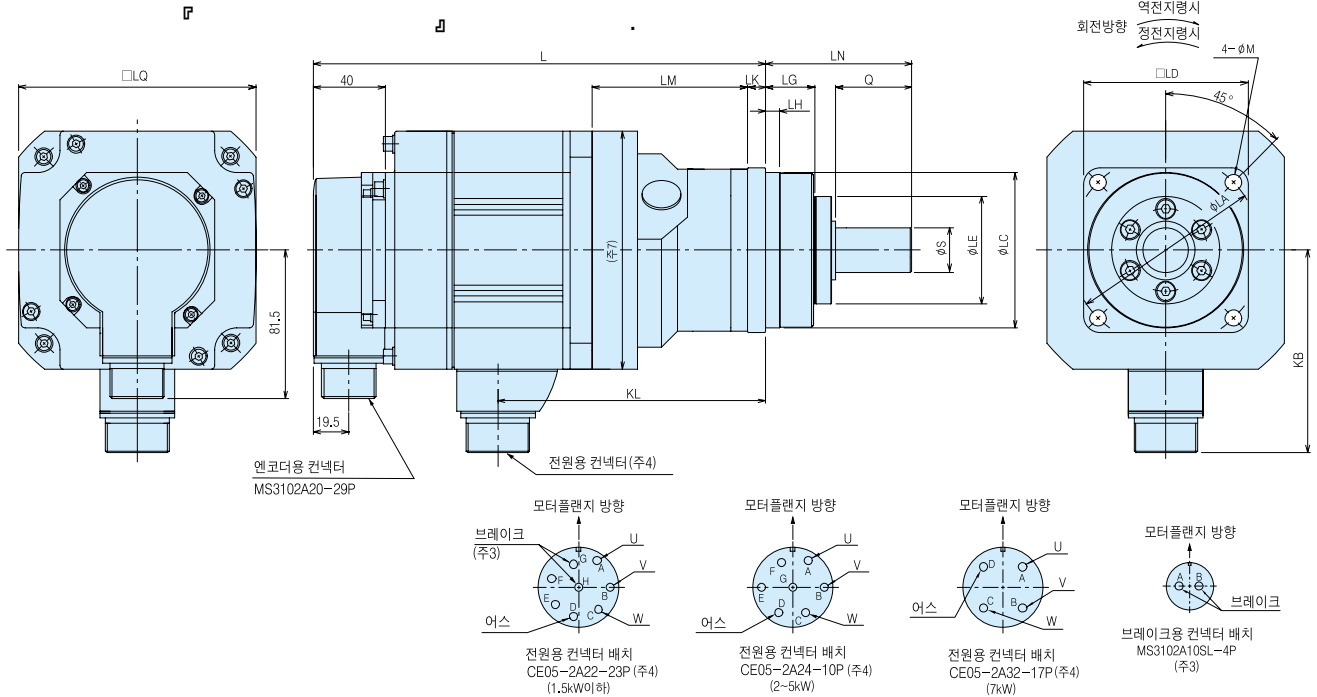

(: mm)

		J (x 10 ⁻⁴ kg · m ²)															(kg)					
			L	LA	LC	LD	LE	S	LG	LH	Q	LN	LK	LM	KL	M		KB	LQ			
HC - SFS52(4)(B)G7	1/5	7.29 (9.29)	215(248)	105	85h7	90	59	25h7	27	8	42	80	10	85	146.5	9	111	130	8.2(10.2)			
	1/11	7.16 (9.16)																			8.4(10.4)	
	1/21	9.50 (11.5)	227(260)	135	115h7	120	84	40h7	35	13	82	133	13	94	158.5	11					12.9(14.9)	
	1/33	9.30 (11.3)																				
	1/45	9.30 (11.3)																				
HC - SFS102(4)(B)G7	1/5	14.4 (16.4)	240(273)	105	85h7	90	59	25h7	27	8	42	80	10	85	171.5	9			10.2(12.2)			
	1/11	17.1 (19.1)	252(285)	135	115h7	120	84	40h7	35	13		133	13	94	183.5	11			14.9(16.9)			
	1/21	16.6 (18.6)									82											
	1/33	18.4 (20.4)	268(301)	190	165h8	170	122	50h7	53	13		156	16	107	199.5	14			26.0(28.0)			
	1/45	18.4 (20.4)																				
HC - SFS152(4)(B)G7	1/5	20.7 (22.7)	265(298)	105	85h7	90	59	25h7	27	8	42	80	10	85	196.5	9			12.2(14.2)			
	1/11	23.4 (25.4)	277(310)	135	115h7	120	84	40h7	35	13		133	13	94	208.5	11			16.9(18.9)			
	1/21	25.7 (27.7)																				
	1/33	24.7 (26.7)	293(326)	190	165h8	170	122	50h7	53	13		156	16	107	224.5	14			28.0(30.0)			
	1/45	24.7 (26.7)																				
HC - SFS202(4)(B)G7	1/5	47.4 (57.4)	274(322)	135	115h7	120	84	40h7	35	13		133	13	116(7)	197.5	11			20.9(26.9)			
	1/11	47.0 (57.0)																	21.4(27.4)			
	1/21	49.0 (59.0)	294(342)	190	165h8	170	122	50h7	53	13	82	156	16	133(7)	217.5	14			32.1(38.1)			
	1/33	47.9 (57.9)																				
	1/45	47.9 (57.9)																				
HC - SFS352(4)(B)G7	1/5	86.9 (96.9)	316(364)	135	115h7	120	84	40h7	35	13		133	13	116(7)	239.5	11	142	176	27.9(33.9)			
	1/11	90.4 (100)	336(384)												259.5				39.1(45.1)			
	1/21	88.5 (98.5)													280.5	14			41.6(47.6)			
HC - SFS502(4)(B)G7	1/5	113 (123)	357(405)	190	165h8	170	122	50h7	53	13		156	16	133(7)					43.1(49.1)			
	1/11	109 (119)																				
HC - SFS702(4)(B)G7	1/5	172 (182)	441(489)												359.5		150		50.6(56.6)			

1. ()
2. ()
- 3.
4. HC - SFS (B)
5. (+)
6. 가
7. LM (7)

180 가

1~3mm

가

HC-LFS52(B), HC-LFS102(B), HC-LFS152(B)

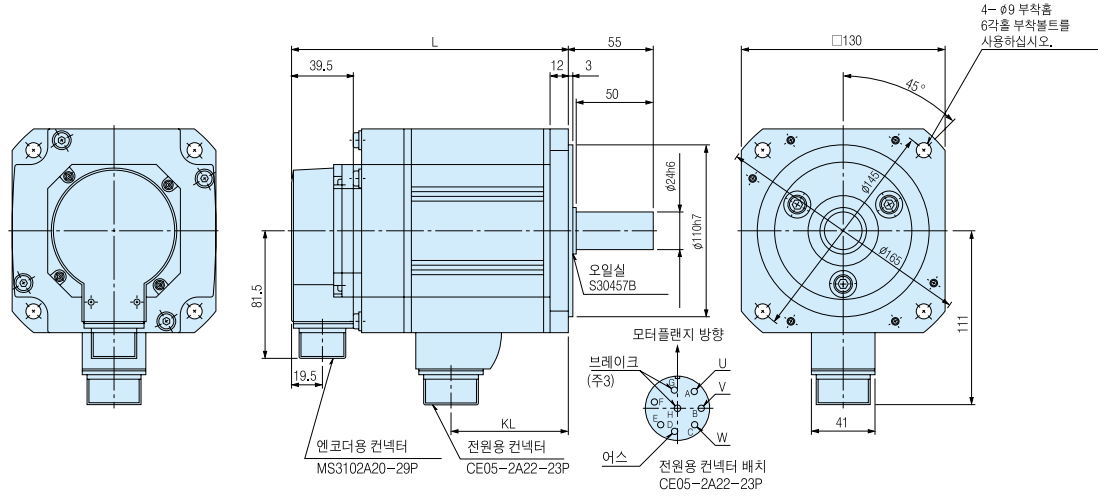

	L	KL
HC-LFS52(B)	145.5(178.5)	77
HC-LFS102(B)	165.5(198.5)	97
HC-LFS152(B)	193(226)	124.5

(: mm)

HC-LFS202(B), HC-LFS302(B)

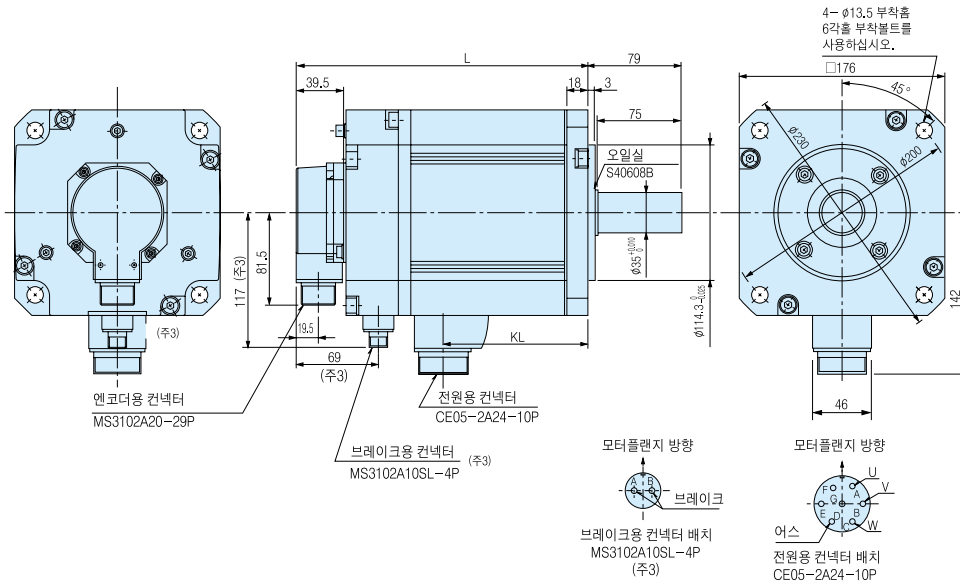

	L	KL
HC-LFS202(B)	200(248)	123.5
HC-LFS302(B)	250(298)	173.5

(: mm)

1. ()
2. ()
3. ()
4. 가

HC-RFS103(B), HC-RFS153(B), HC-RFS203(B)

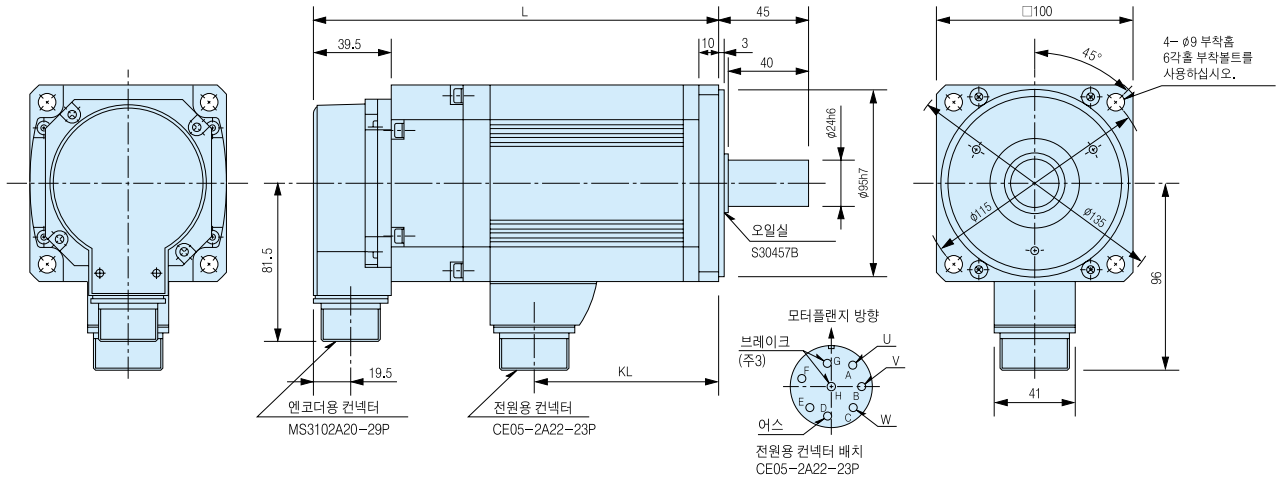

	L	KL
HC-RFS103(B)	147(185)	71
HC-RFS153(B)	172(210)	96
HC-RFS203(B)	197(235)	121

(: mm)

HC-RFS353(B), HC-RFS503(B)

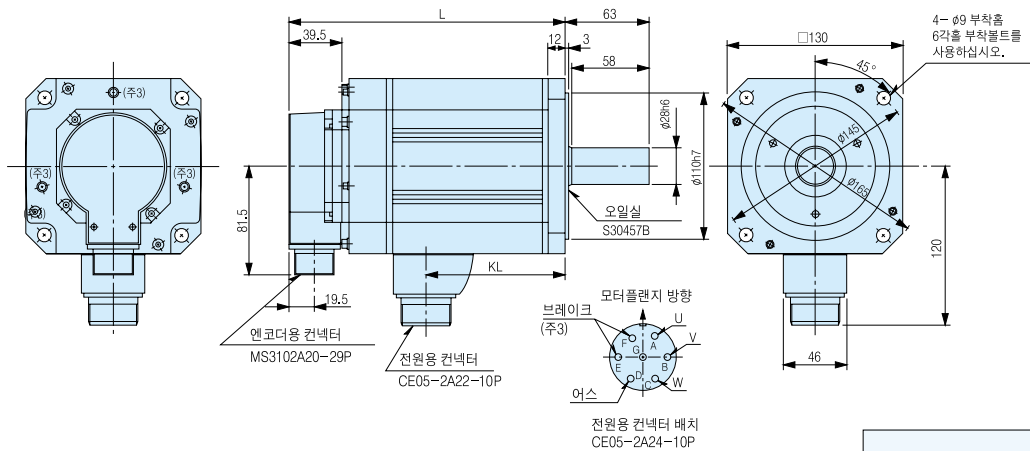

	L	KL
HC-RFS353(B)	214(254)	148
HC-RFS503(B)	274(311)	205

(: mm)

1. ()
2. ()
3. ()
4. 가

HC-RFS (B)G2

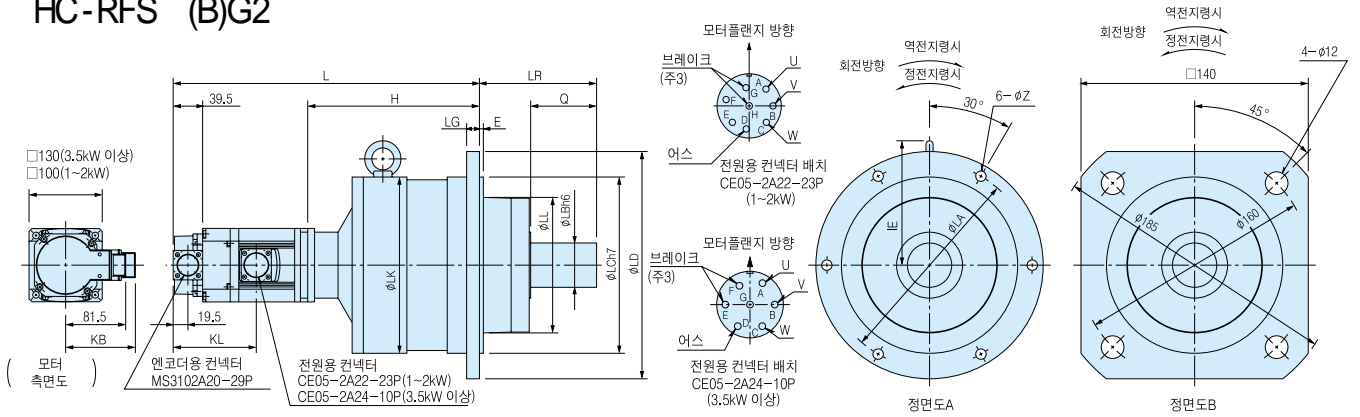

(: mm)

		J (x 10 ⁻⁴ kg · m ²)																	KB	Q		(kg)
			L	LA	LB	LC	LD	LG	LK	LL	LR	IE	KL	Z	E	H						
HC - RFS103(B)G2	1/5	4.95 (5.3)	301(339)	-	35	130	-	12	132	94	100	-	76 (113.5)	-	3	154	96	55	B	11.9(14)		
	1/9	4.6 (4.95)	313(351)	-	35	130	-	12	132	94	100	-		-	3	166		55	B	11.9(14)		
	1/20	8.35 (8.7)	354(392)	220	50	190	245	15	190	135	140	136.5		12	5	207		75	A	28.9(31)		
	1/29	6.45 (6.8)	354(392)	220	50	190	245	15	190	135	140	136.5		12	5	207		75	A	28.9(31)		
HC - RFS153(B)G2	1/45	5.48 (5.83)	364(402)	220	50	190	245	15	190	135	140	136.5	12	5	217	75	A	28.9(31)				
	1/5	5.35 (5.7)	326(364)	-	35	130	-	12	132	94	100	-	-	3	154	55	B	13(15.1)				
	1/9	6.68 (7.03)	375(413)	220	50	190	245	15	190	135	140	136.5	12	5	203	75	A	30(32.1)				
	1/20	8.75 (9.1)	379(417)	220	50	190	245	15	190	135	140	136.5	12	5	207	75	A	30(32.1)				
HC - RFS203(B)G2	1/29	6.85 (7.2)	379(417)	220	50	190	245	15	190	135	140	136.5	12	5	207	75	A	30(32.1)				
	1/45	8.55 (8.9)	410(448)	280	60	240	310	18	240	186	160	171	14	5	238	90	A	50(52.1)				
	1/5	5.75 (6.1)	351(389)	-	35	130	-	12	132	94	100	-	-	3	154	55	B	14.2(16.3)				
	1/9	7.08 (7.43)	400(438)	220	50	190	245	15	190	135	140	136.5	12	5	203	75	A	31.2(33.3)				
HC - RFS353(B)G2	1/20	9.15 (9.5)	404(442)	220	50	190	245	15	190	135	140	136.5	12	5	207	75	A	31.2(33.3)				
	1/29	12.7 (13.1)	425(463)	280	60	240	310	18	240	186	160	171	14	5	228	90	A	51.2(53.3)				
	1/45	8.95 (9.3)	435(473)	280	60	240	310	18	240	186	160	171	14	5	238	90	A	51.2(53.3)				
	1/5	18.8 (20.8)	418(455)	220	50	190	245	15	190	135	140	136.5	12	5	201	75	A	30(33)				
HC - RFS503(B)G2	1/9	21.1 (23.1)	470(507)	280	60	240	310	18	240	186	160	171	69.5 (106)	14	5	253	120	90	A	57(60)		
	1/20	28.8 (30.8)	470(507)	280	60	240	310	18	240	186	160	171		14	5	253		90	A	57(60)		
	1/29	22.0 (24.0)	470(507)	280	60	240	310	18	240	186	160	171		14	5	253		90	A	57(60)		
	1/5	32.4 (34.4)	495(532)	280	60	240	310	18	240	186	160	171		14	5	221		90	A	52(56)		
HC - RFS503(B)G2	1/9	24.5 (26.5)	527(564)	280	60	240	310	18	240	186	160	171	14	5	253	90	A	62(66)				
	1/20	32.2 (34.2)	527(564)	280	60	240	310	18	240	186	160	171	14	5	253	90	A	62(66)				

1. ()
2. ()
- 3.
4. (+)
5. 가

가 , 1-3mm 가

HC-RFS (B)G5

가

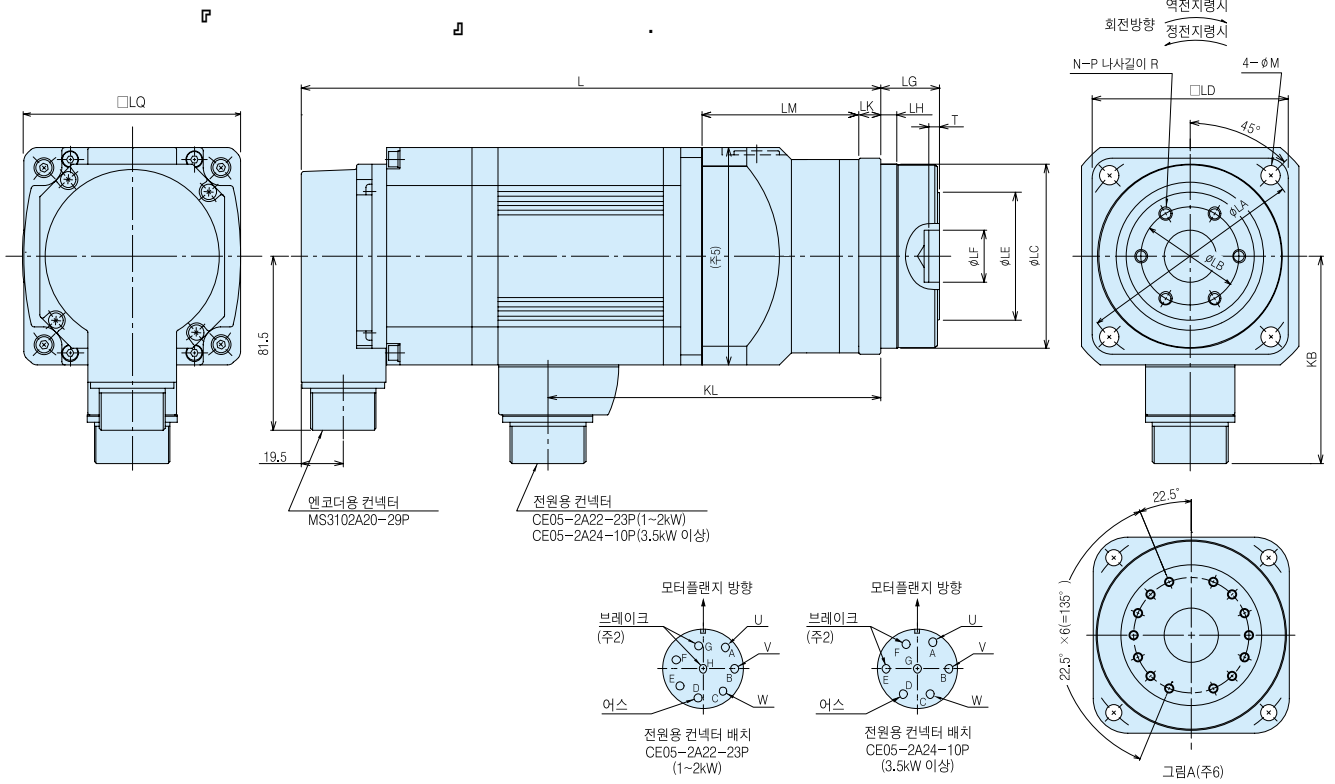

(: mm)

		J (x 10 ⁻⁴ kg · m ²)	가													N	P	R	M	KB	LQ	(kg)		
			L	LA	LB	LC	LD	LE	LF	LG	LH	LK	LM	KL	T									
HC - RFS103(B)G5	1/5	2.33 (2.68)	229(267)	105	45	85h7	90	59	24H7	27 ^{+0.4} _{-0.5}	8	10	72	153	5	6	M6	10	9	96	100			6.4(8.5)
	1/11	2.25 (2.60)																						6.6(8.7)
	1/21	4.40 (4.75)	257(295)	135	60	115h7	120	84	32H7	35 ^{+0.4} _{-0.5}	13	13	97(5)	181	7	14(6)	M8	12	11	14				10.4(12.5)
	1/33	4.20 (4.55)																						19.9(22.0)
HC - RFS153(B)G5	1/5	6.10 (6.45)	270(308)	190	100	165h8	170	122	47H7	53 ^{+0.5} _{-0.8}	13	16	107	194	7	14(6)	M6	10	9	96	100			7.5(9.5)
	1/11	5.20 (5.55)																						11.5(13.5)
	1/21	4.80 (5.15)	282(320)	135	60	115h7	120	84	32H7	35 ^{+0.4} _{-0.5}	13	13	97(5)	206	5	6	M8	12	11	14				21.0(23.0)
	1/33	6.60 (6.95)																						21.0(23.0)
HC - RFS203(B)G5	1/5	3.13 (3.48)	279(317)	105	45	85h7	90	59	24H7	27 ^{+0.4} _{-0.5}	8	10	72	203	5	6	M6	10	9	96	100			8.7(10.8)
	1/11	5.60 (5.95)																						12.7(14.8)
	1/21	8.00 (8.35)	320(358)	190	100	165h8	170	122	47H7	53 ^{+0.5} _{-0.8}	13	16	107	244	7	14(6)	M8	12	11	14				22.2(24.3)
	1/33	7.00 (7.35)																						22.2(24.3)
HC - RFS353(B)G5	1/5	13.5 (16.7)	346(383)	135	60	115h7	120	84	32H7	35 ^{+0.4} _{-0.5}	13	13	116	277	5	6	M8	12	11	120	130			18.5(21.5)
	1/11	13.3 (16.5)																						19.0(22.0)
	1/21	15.3 (18.5)	366(403)	190	100	165h8	170	122	47H7	53 ^{+0.5} _{-0.8}	13	16	133	297	7	14(6)	M8	12	11	14				28.1(31.1)
	1/33	14.4 (17.6)																						28.1(31.1)
HC - RFS503(B)G5	1/5	16.9 (20.4)	403(440)	135	60	115h7	120	84	32H7	35 ^{+0.4} _{-0.5}	13	13	116	334	5	6	M8	12	11	120	130			33.5(37.5)
	1/11	20.5 (24.0)																						33.5(37.5)
	1/21	18.7 (22.2)	423(460)	190	100	165h8	170	122	47H7	53 ^{+0.5} _{-0.8}	13	16	133	354	7	14(6)	M8	12	11	14			33.1(37.1)	

1. ()

2. ()

3. (+)

4. 가 가 1~3mm 가

5. LM (5)

ø135 가

6. A

HC-RFS (B)G7

가

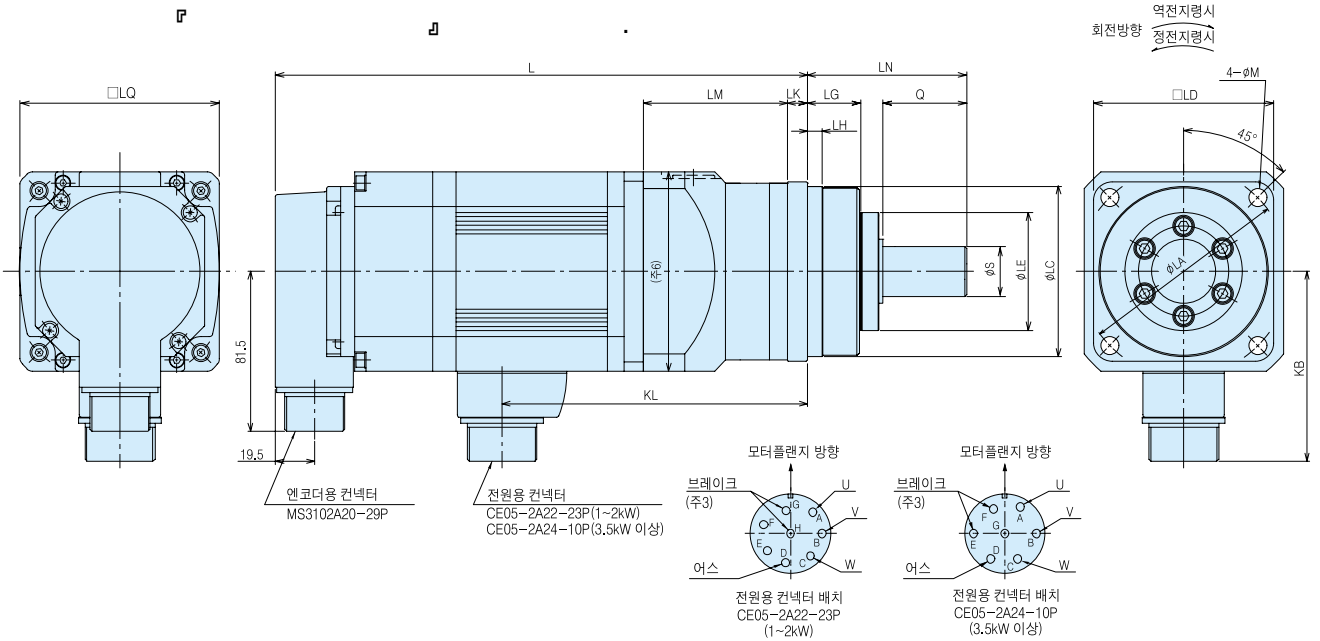

(: mm)

		J(× 10 ⁻⁴ kg · m ²)														KB	LQ	(kg)		
			L	LA	LC	LD	LE	S	LG	LH	Q	LN	LK	LM	KL				M	
HC - RFS103(B)G7	1/5	2.37 (2.72)	229(267)	105	85h7	90	59	25h7	27	8	42	80	10	72	153	9	96	100	6.8(8.9)	
	1/11	2.25 (2.60)																		7.0(9.1)
	1/21	4.40 (4.75)	257(295)	135	115h7	120	84	40h7	35	13	82	133	13	97(6)	181	11			11.8(13.9)	
	1/33	4.20 (4.55)																		22.9(25.0)
HC - RFS153(B)G7	1/5	2.77 (3.12)	254(292)	105	85h7	90	59	25h7	27	8	42	80	10	72	178	9	96	100	7.9(9.9)	
	1/11	5.30 (5.65)	282(320)	135	115h7	120	84	40h7	35	13	82	133	13	97(6)	206	11			12.9(14.9)	
	1/21	4.80 (5.15)																		24.0(26.0)
	1/33	6.60 (6.95)	295(333)	190	165h8	170	122	50h7	53	13		156	16	107	219	14				
HC - RFS203(B)G7	1/5	3.17 (3.52)	279(317)	105	85h7	90	59	25h7	27	8	42	80	10	72	203	9	96	100	9.1(11.2)	
	1/11	5.70 (6.05)	307(345)	135	115h7	120	84	40h7	35	13		133	13	97(6)	231	11			14.1(16.2)	
	1/21	8.00 (8.35)																		
	1/33	7.00 (7.35)	320(358)	190	165h8	170	122	50h7	53	13		156	16	107	244	14				
HC - RFS353(B)G7	1/5	13.8 (17.0)	346(383)	135	115h7	120	84	40h7	35	13	82	133	13	116	277	11	120	130	19.9(22.9)	
	1/11	13.4 (16.6)																		20.4(23.4)
	1/21	15.4 (18.6)	366(403)	190	165h8	170	122	50h7	53	13		156	16	133	297	14				
	1/33	14.4 (17.6)																		31.1(34.1)
HC - RFS503(B)G7	1/5	17.2 (20.7)	403(440)	135	115h7	120	84	40h7	35	13		133	13	116	334	11		24.9(28.9)		
	1/11	20.7 (24.2)	423(460)	190	165h8	170	122	50h7	53	13		156	16	133	354	14		36.1(40.1)		

1. ()
2. ()
- 3.
4. (+)
5. 가 가 1~3mm 가
6. LM (6) ø135 가

HA-LFS502

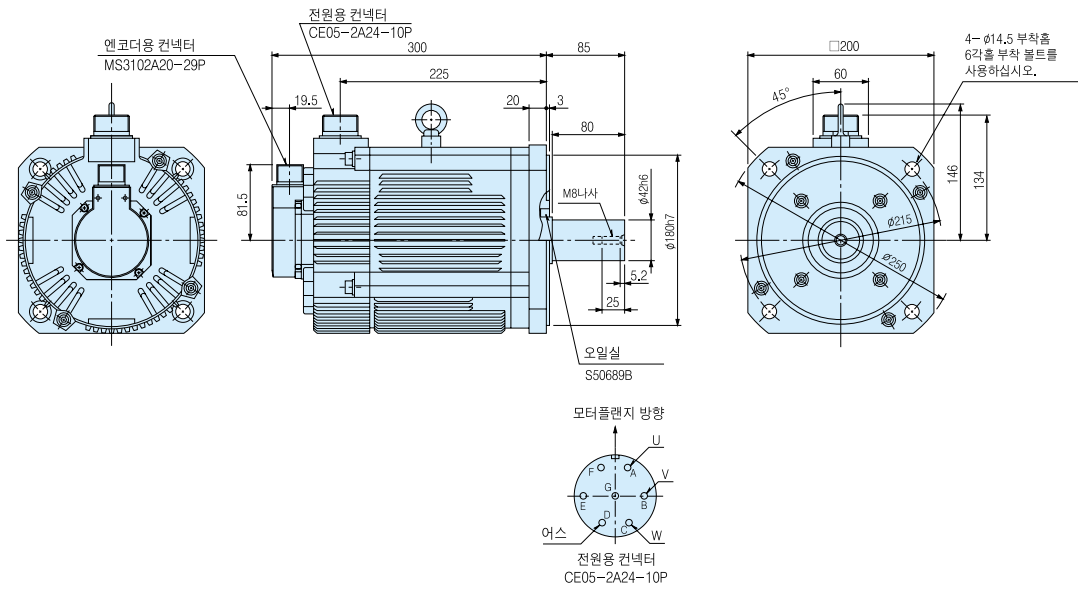

(: mm)

HA-LFS702

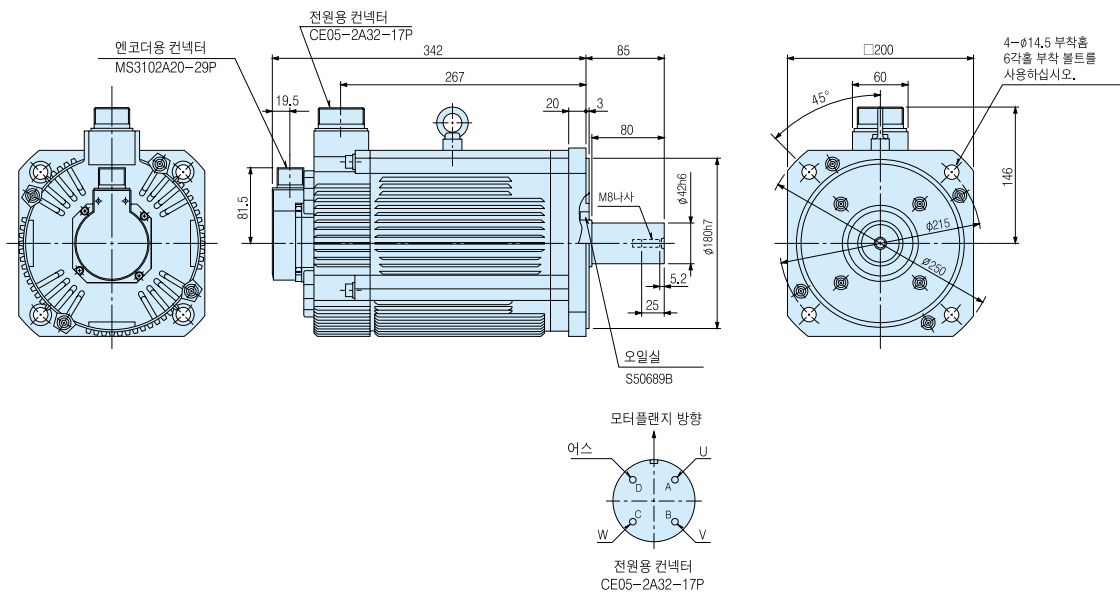

(: mm)

- 1. 가
- 2. 가

HA-LFS601(B), HA-LFS6014(B) () (7)
 HA-LFS701M(B) () (7), HA-LFS701M4(B) () (7)
 HA-LFS11K2(B), HA-LFS11K24(B)

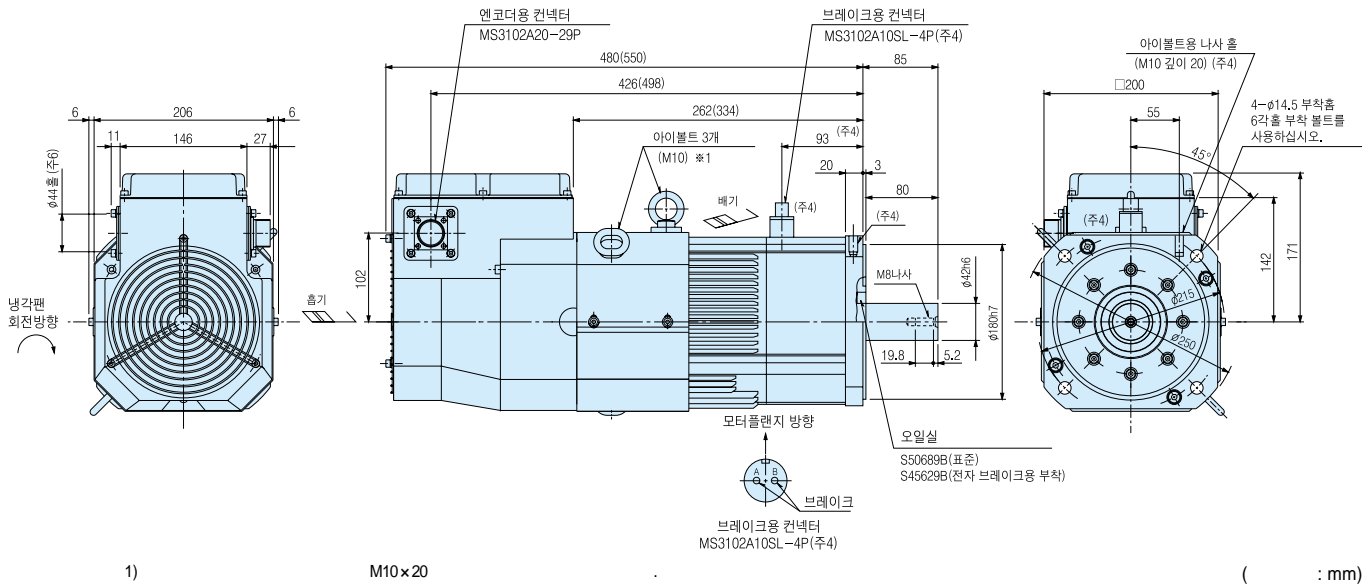

1) M10×20 (: mm)

HA-LFS801(B), HA-LFS12K1(B), HA-LFS8014(B) () (7), HA-LFS12K14(B) () (7)
 HA-LFS11K1M(B), HA-LFS15K1M(B), HA-LFS11K1M4(B), HA-LFS15K1M4(B)
 HA-LFS15K2(B), HA-LFS22K2(B), HA-LFS15K24(B), HA-LFS22K24(B)

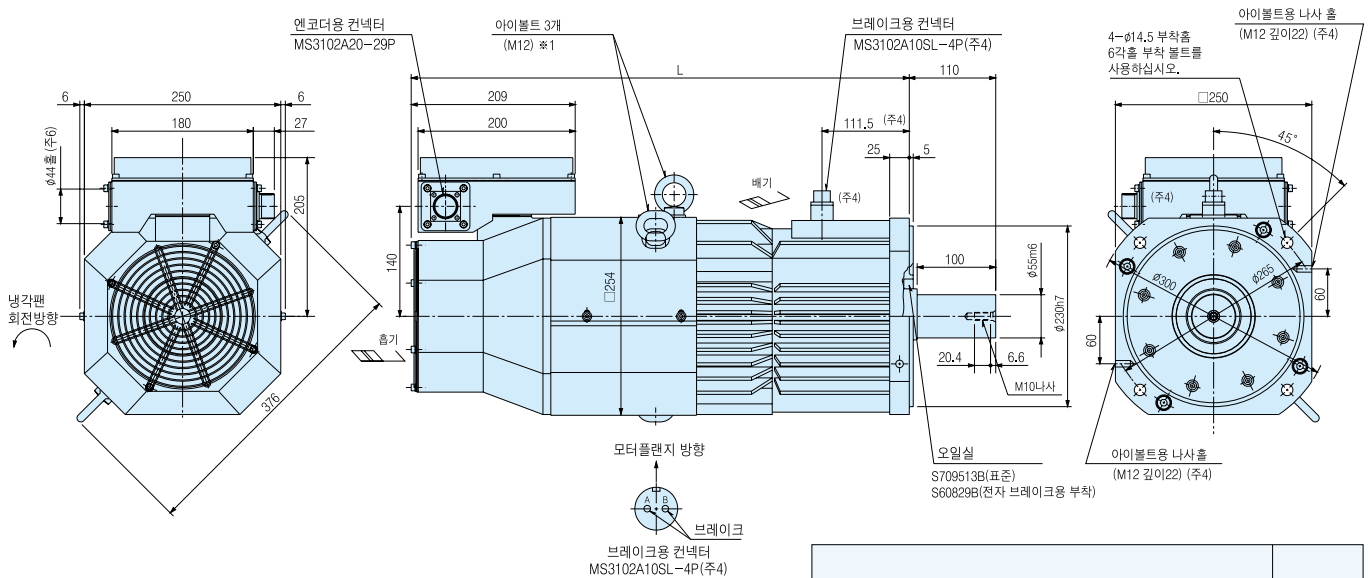

1) M12×20 (: mm)

	1000r/min	1500r/min	2000r/min	L
HA-LFS801(B)	HA-LFS11K1M(B)	HA-LFS15K2(B)		495(610)
HA-LFS8014(B) ()	HA-LFS11K1M4(B)	HA-LFS15K24(B)		
HA-LFS12K1(B)	HA-LFS15K1M(B)	HA-LFS22K2(B)		555(670)
HA-LFS12K14(B) ()	HA-LFS15K1M4(B)	HA-LFS22K24(B)		

1. 가 ()
2. 가
3. ()
- 4.
5. 100mm 가
6. 가
- 7.

HA-LFS30K1M
HA-LFS30K2, HA-LFS37K2

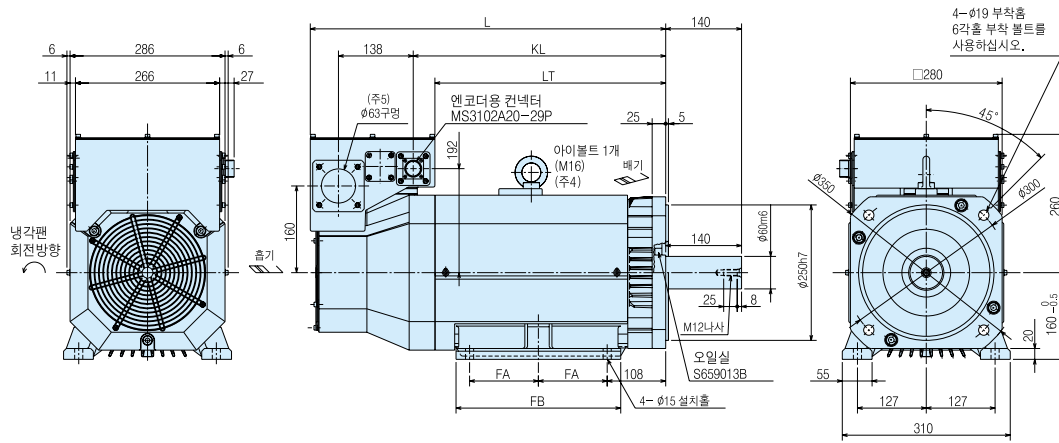

	1500r/min	2000r/min	L	LT	KL	FA	FB
	-	HA-LFS30K2	615	381	421	105	260
	HA-LFS30K1M	HA-LFS37K2	660	426	466	127	304

(: mm)

HA-LFS37K1, HA-LFS37K14
HA-LFS50K1M4

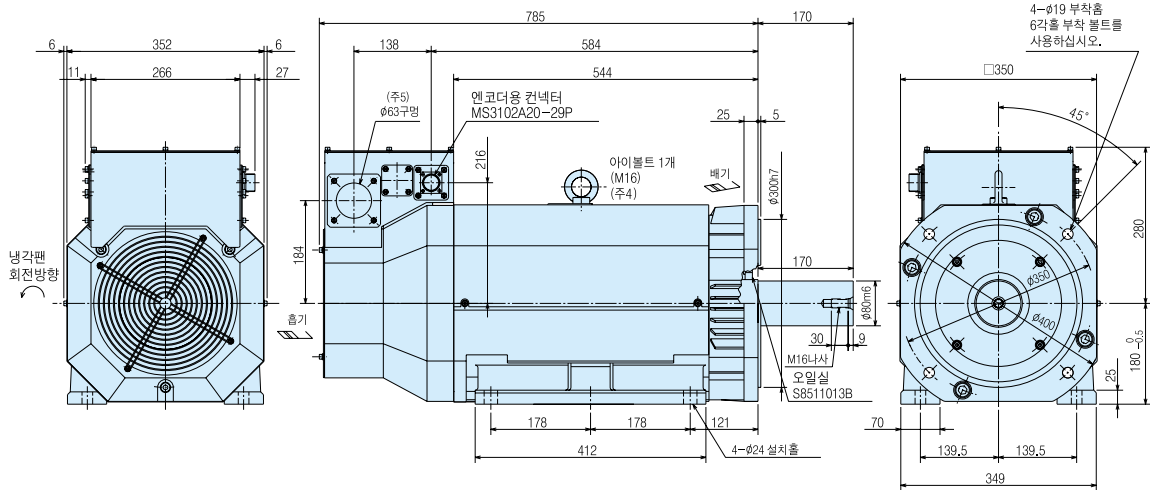

(: mm)

1. 가
2. 가
3. 150mm
4. M16 x 20
5. 가
6. 가

HA-LFS15K1, HA-LFS20K1, HA-LFS15K14, HA-LFS20K14 () (6)
 HA-LFS22K1M, HA-LFS22K1M4, HA-LFS30K1M4
 HA-LFS30K24, HA-LFS37K24

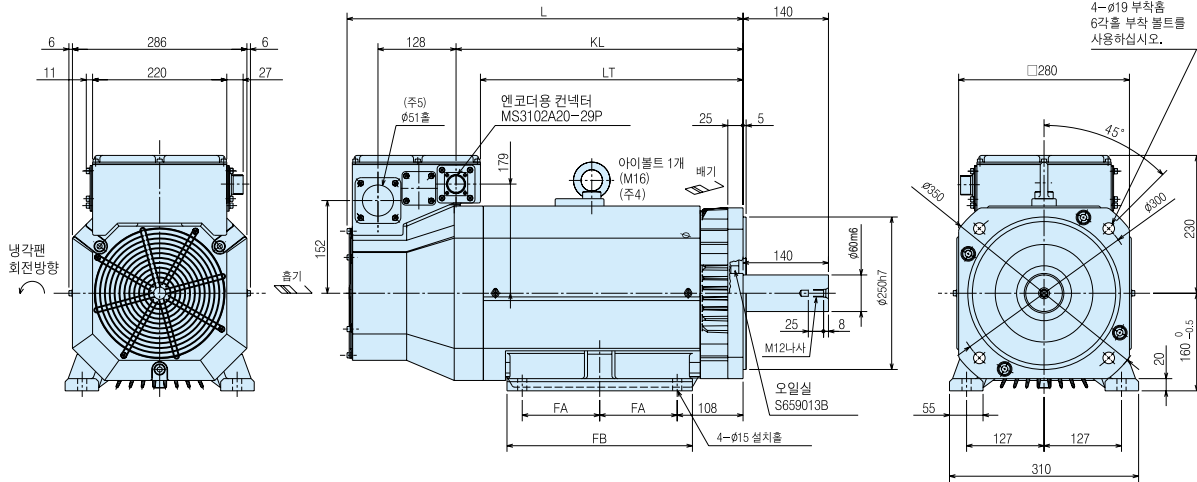

			L	LT	KL	FA	FB
1000r/min	1500r/min	2000r/min					
HA-LFS15K1 HA-LFS15K14	HA-LFS22K1M HA-LFS22K1M4	HA-LFS30K24	605	386	426	105	260
HA-LFS20K1 HA-LFS20K14 ()	HA-LFS30K1M4	HA-LFS37K24	650	431	471	127	304

() () : mm

HA-LFS25K1, HA-LFS30K1, HA-LFS25K14 () (6), HA-LFS30K14
 HA-LFS37K1M, HA-LFS37K1M4, HA-LFS45K1M4
 HA-LFS45K24, HA-LFS55K24

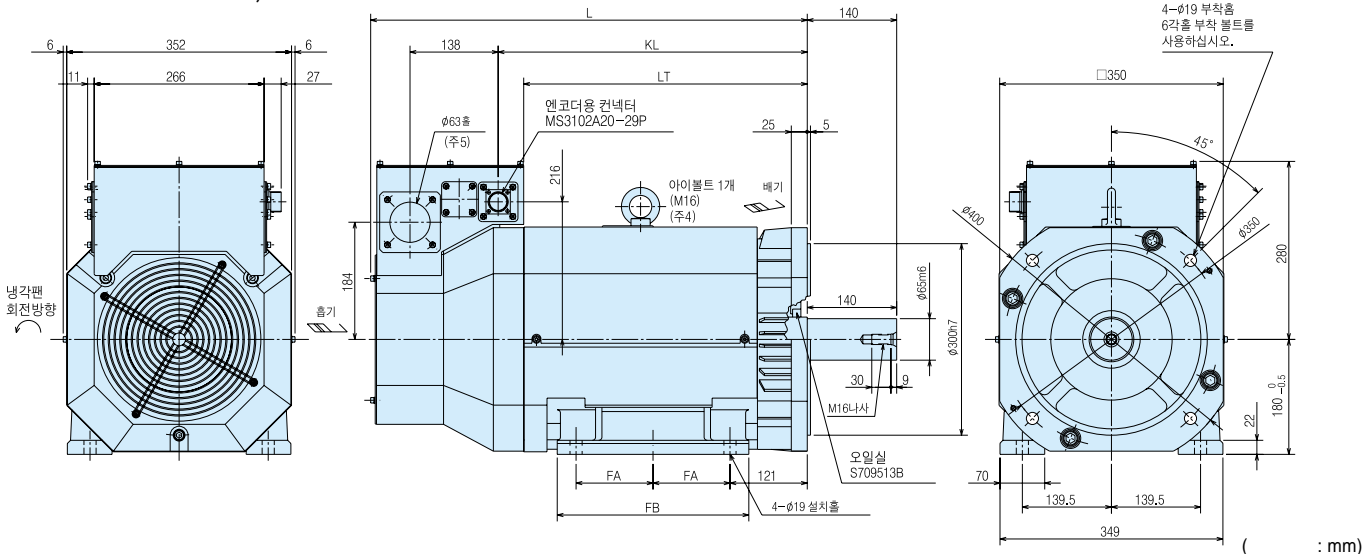

			L	LT	KL	FA	FB
1000r/min	1500r/min	2000r/min					
HA-LFS25K1 HA-LFS25K14 ()	HA-LFS37K1M HA-LFS37K1M4	HA-LFS45K24	640	399	439	101.5	262
HA-LFS30K1 HA-LFS30K14	HA-LFS45K1M4	HA-LFS55K24	685	444	484	120.5	300

() () : mm

1.)
 2. 가
 3. 150mm
 4. M16 x 20
 5. 가
 6.
 7.

HC-UFS72(B), HC-UFS152(B)

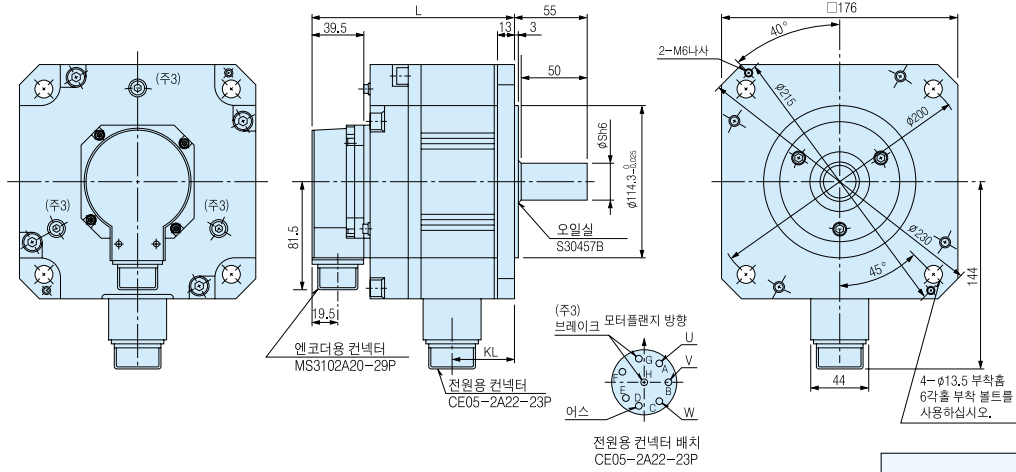

	L	KL	S
HC - UFS72(B)	110.5(144)	38	22
HC - UFS152(B)	120(153.5)	47.5	28

(: mm)

HC-UFS202(B)~HC-UFS502(B)

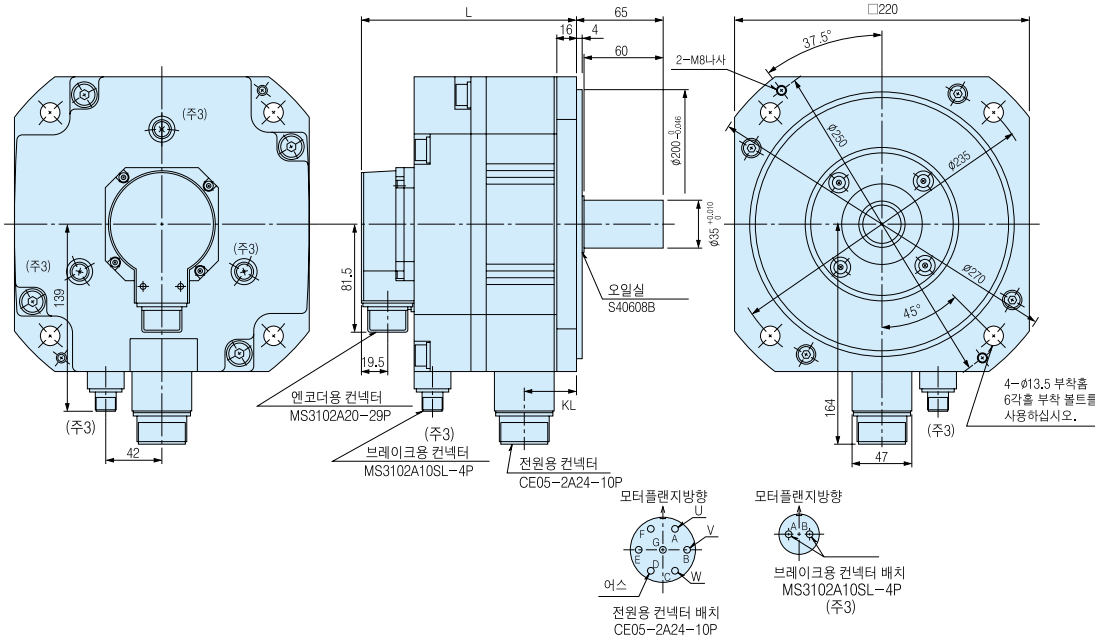

	L	KL
HC - UFS202(B)	118(161)	42.5
HC - UFS352(B)	142(185)	66.5
HC - UFS502(B)	166(209)	90.5

(: mm)

1. ()
2. ()
3. ()
4. 가

HC-UFS13(B)

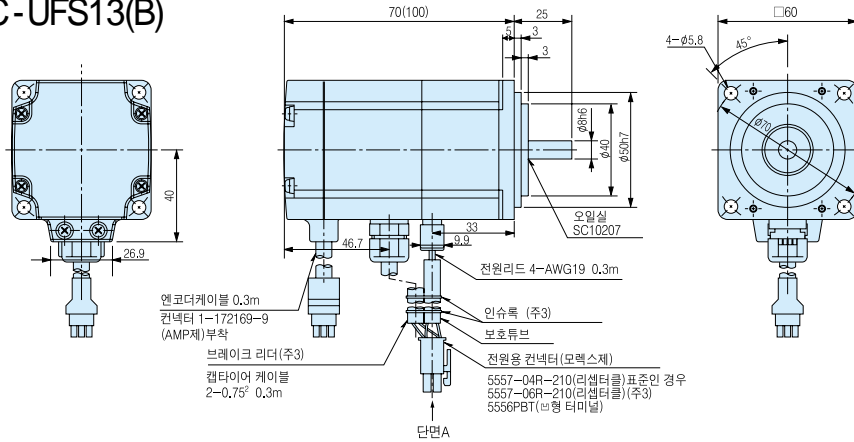

<표준인 경우>

전원용 컨넥터핀 배열	
핀번호	신호열
1	U상
2	V상
3	W상
4	어스

<브레이크를 부착한 경우>

전원용 컨넥터핀 배열	
핀번호	신호열
1	U상
2	V상
3	W상
4	어스
5	B1
6	B2

() : mm

HC-UFS23(B), HC-UFS43(B)

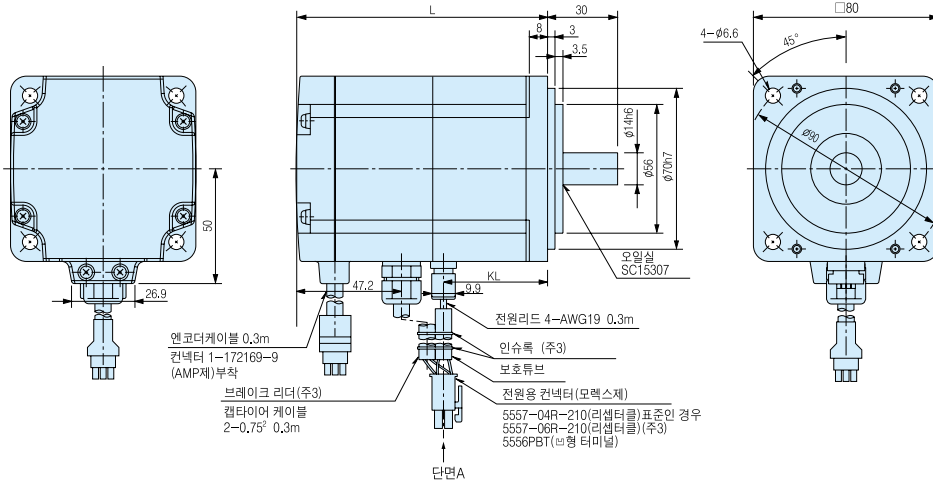

<표준인 경우>

전원용 컨넥터핀 배열	
핀번호	신호열
1	U상
2	V상
3	W상
4	어스

<브레이크를 부착한 경우>

전원용 컨넥터핀 배열	
핀번호	신호열
1	U상
2	V상
3	W상
4	어스
5	B1
6	B2

	L	KL
HC - UFS23(B)	77(111)	43.8
HC - UFS43(B)	92(126)	58.8

() : mm

HC-UFS73(B)

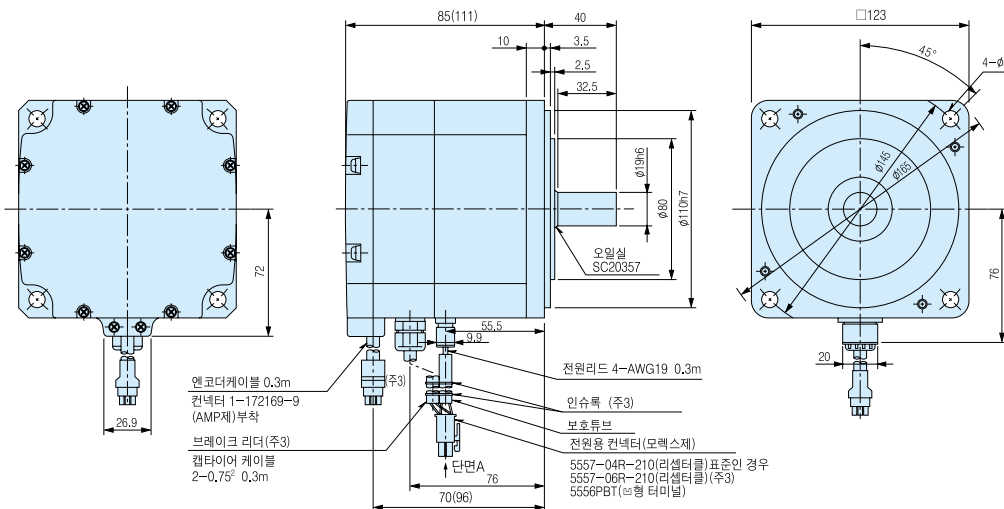

<표준인 경우>

전원용 컨넥터핀 배열	
핀번호	신호열
1	U상
2	V상
3	W상
4	어스

<브레이크를 부착한 경우>

전원용 컨넥터핀 배열	
핀번호	신호열
1	U상
2	V상
3	W상
4	어스
5	B1
6	B2

() : mm

1. ()
2. ()
3. ()
4. 가

A

B

CP

CL

MR - J2S - A	MR - J2S - 10A	50W, 100W	AC200~230V	AC230V		
	MR - J2S - 10A1		AC100~120V			
	MR - J2S - 20A	200W	AC200~230V	AC230V		
	MR - J2S - 20A1		AC100~120V			
	MR - J2S - 40A	400W	AC200~230V	AC230V		
	MR - J2S - 40A1		AC100~120V			
	MR - J2S - 60A	600W	AC200~230V	AC230V		
	MR - J2S - 70A	750W				
	MR - J2S - 70A - U005				HC - KFS46	
	MR - J2S - 70A - U006				HC - KFS410	
	MR - J2S - 100A	1kW	AC200~230V			
	MR - J2S - 200A	2kW				
	MR - J2S - 350A	3.5kW				
	MR - J2S - 500A	5kW				
	MR - J2S - 700A	7kW				
	MR - J2S - 11KA	11kW				
	MR - J2S - 15KA	15kW				
	MR - J2S - 22KA	22kW				
	MR - J2S - 30KA	30kW				
	MR - J2S - 37KA	37kW				
	MR - J2S - 60A4	600W			AC380~480V	
	MR - J2S - 100A4	1kW				
	MR - J2S - 200A4	2kW				
	MR - J2S - 350A4	3.5kW				
	MR - J2S - 500A4	5kW				
	MR - J2S - 700A4	7kW				
	MR - J2S - 11KA4	11kW				
	MR - J2S - 15KA4	15kW				
	MR - J2S - 22KA4	22kW				
	MR - J2S - 30KA4	30kW				
	MR - J2S - 37KA4	37kW				
	MR - J2S - 45KA4	45kW				
MR - J2S - 55KA4	55kW					
MR - J2S - B	MR - J2S - 10B	50W, 100W	AC200~230V	AC230V		
	MR - J2S - 10B1		AC100~120V			
	MR - J2S - 20B	200W	AC200~230V	AC230V		
	MR - J2S - 20B1		AC100~120V			
	MR - J2S - 40B	400W	AC200~230V	AC230V		
	MR - J2S - 40B1		AC100~120V			
	MR - J2S - 60B	600W	AC200~230V	AC230V		
	MR - J2S - 70B	750W				
	MR - J2S - 70B - U005				HC - KFS46	
	MR - J2S - 70B - U006				HC - KFS410	
	MR - J2S - 100B	1kW	AC200~230V			
	MR - J2S - 200B	2kW				
	MR - J2S - 350B	3.5kW				
	MR - J2S - 500B	5kW				
	MR - J2S - 700B	7kW				
	MR - J2S - 11KB	11kW				
	MR - J2S - 15KB	15kW				
	MR - J2S - 22KB	22kW				
	MR - J2S - 30KB	30kW				
	MR - J2S - 37KB	37kW				
	MR - J2S - 60B4	600W			AC380~480V	
	MR - J2S - 100B4	1kW				
	MR - J2S - 200B4	2kW				
	MR - J2S - 350B4	3.5kW				

⋮

MR - J2S - B	MR - J2S - 500B4	5kW	AC380~480V		
	MR - J2S - 700B4	7kW			
	MR - J2S - 11KB4	11kW			
	MR - J2S - 15KB4	15kW			
	MR - J2S - 22KB4	22kW			
	MR - J2S - 30KB4	30kW			
	MR - J2S - 37KB4	37kW			
	MR - J2S - 45KB4	45kW			
	MR - J2S - 55KB4	55kW			
MR - J2S - CP	MR - J2S - 10CP	50W, 100W	AC200~230V	AC230V	
	MR - J2S - 10CP1		AC100~120V		
	MR - J2S - 20CP	200W	AC200~230V	AC230V	
	MR - J2S - 20CP1		AC100~120V		
	MR - J2S - 40CP	400W	AC200~230V	AC230V	
	MR - J2S - 40CP1		AC100~120V		
	MR - J2S - 60CP	600W	AC200~230V	AC230V	
	MR - J2S - 70CP	750W			
	MR - J2S - 70CP - U005				HC - KFS46
	MR - J2S - 70CP - U006		HC - KFS410		
	MR - J2S - 100CP	1kW	AC200~230V		
	MR - J2S - 200CP	2kW			
	MR - J2S - 350CP	3.5kW			
	MR - J2S - 500CP	5kW			
	MR - J2S - 700CP	7kW			
MR - J2S - CP CC - Link	MR - J2S - 10CP - S084	50W, 100W	AC200~230V	AC230V	
	MR - J2S - 10CP1 - S084		AC100~120V		
	MR - J2S - 20CP - S084	200W	AC200~230V	AC230V	
	MR - J2S - 20CP1 - S084		AC100~120V		
	MR - J2S - 40CP - S084	400W	AC200~230V	AC230V	
	MR - J2S - 40CP1 - S084		AC100~120V		
	MR - J2S - 60CP - S084	600W	AC200~230V	AC230V	
	MR - J2S - 70CP - S084	750W			
	MR - J2S - 70CP - S084U005				HC - KFS46
	MR - J2S - 70CP - S084U006		HC - KFS410		
	MR - J2S - 100CP - S084	1kW	AC200~230V		
	MR - J2S - 200CP - S084	2kW			
	MR - J2S - 350CP - S084	3.5kW			
	MR - J2S - 500CP - S084	5kW			
	MR - J2S - 700CP - S084	7kW			
CC - Link	MR - J2S - T01				
MR - J2S - CL	MR - J2S - 10CL	50W, 100W	AC200~230V	AC230V	
	MR - J2S - 10CL1		AC100~120V		
	MR - J2S - 20CL	200W	AC200~230V	AC230V	
	MR - J2S - 20CL1		AC100~120V		
	MR - J2S - 40CL	400W	AC200~230V	AC230V	
	MR - J2S - 40CL1		AC100~120V		
	MR - J2S - 60CL	600W	AC200~230V	AC230V	
	MR - J2S - 70CL	750W			
	MR - J2S - 70CL - U005				HC - KFS46
	MR - J2S - 70CL - U006		HC - KFS410		
	MR - J2S - 100CL	1kW	AC200~230V		
	MR - J2S - 200CL	2kW			
	MR - J2S - 350CL	3.5kW			
	MR - J2S - 500CL	5kW			
	MR - J2S - 700CL	7kW			
	MR - HP30KA	30kW, 37kW	AC200~230V		
	MR - HP55KA4	30kW, 37kW, 45kW, 55kW	AC380~480V		

⋮

(1)	MR - JCCBL2M - H	2m		HC - KFS HC - MFS HC - UFS3000r/min		
	MR - JCCBL5M - H	5m				
	MR - JCCBL10M - H	10m				
	MR - JCCBL20M - H	20m				
	MR - JCCBL30M - H	30m				
	MR - JCCBL50M - H	50m				
	MR - JCCBL2M - L	2m				
	MR - JCCBL5M - L	5m				
	MR - JCCBL10M - L	10m				
	MR - JCCBL20M - L	20m				
	MR - JCCBL30M - L	30m				
	MR - JHSCBL2M - H	2m			IP65, IP67	HC - SFS HC - LFS HC - RFS HA - LFS HC - UFS2000r/min
	MR - JHSCBL5M - H	5m				
	MR - JHSCBL10M - H	10m				
	MR - JHSCBL20M - H	20m				
	MR - JHSCBL30M - H	30m				
	MR - JHSCBL50M - H	50m				
	MR - JHSCBL2M - L	2m				
	MR - JHSCBL5M - L	5m				
	MR - JHSCBL10M - L	10m				
	MR - JHSCBL20M - L	20m				
	MR - JHSCBL30M - L	30m				
	MR - ENCBL2M - H	2m				
	MR - ENCBL5M - H	5m				
	MR - ENCBL10M - H	10m				
	MR - ENCBL20M - H	20m				
	MR - ENCBL30M - H	30m				
	MR - ENCBL50M - H	50m				
MR - J2CNM	(CN2) × 1,	IP65, IP67 , EN	HC - KFS, MFS, UFS3000r/min			
MR - J2CNS	× 1		HC - SFS, HC - LFS, HC - RFS, HA - LFS,			
MR - ENCNS			HC - UFS2000r/min			
MR - PWCNK1		IP65, IP67 , EN	HC - KFS, MFS, UFS3000r/min			
MR - PWCNK2						
MR - PWCNS1			HC - SFS, LFS, UFS2000r/min 1.5kW , HC - RFS 2kW (3)			
MR - PWCNS2			HC - SFS, LFS, UFS2000r/min 2~5kW(2) HC - RFS 3.5~5kW, HA - LFS502			
MR - PWCNS3		IP65, IP67 , EN	HC - SFS702(4), HA - LFS702			
MR - BKCN		IP65, IP67 , EN	HC - SFS, LFS, UFS2000r/min 2kW , HA - LFS1000r/min 12kW , HA - LFS1500r/min 15kW , HA - LFS2000r/min 11~22kW (2)			
CN1 CN5	MR - J2CN1	1 2 : × 1, (CN1A) × 1, (CN1B) × 1 (CN5) × 1, (CN5A) × 1	(CN1A) × 1			
	MR - J2HBUS05M - A	0.5m	(CN1A)			
	MR - J2HBUS1M - A	1m				
	MR - J2HBUS5M - A	5m				
	MR - J2CN1 - A		× 1, (CN1A) × 1			
CN5 CC - Link (4) (5)	MR - J2HBUS05M	0.5m				
	MR - J2HBUS1M	1m				
	MR - J2HBUS5M	5m				

1. 가 가 가 :
 2. HC - SFS121 . :
 3. HC - SFS121 . :
 4. CN5 1m :
 5. CC - Link 0.5m :

	MR - J2CN3TM		
	MR - A - TM		(CN1B) × 1 (CN5B) × 1
	MR - CPCATCBL3M	3m	DOS/V (IBM PC/AT)
	MR - JRPCATCBL3M	3m (MR - J2S - CP(1) - S084)	
	MR - TB20		
	MR - J2TBL05M	0.5m	
	MR - J2TBL1M	1m	
CN4	MR - H3CBL1M	1m	(CN4)
CN1	MR - HP4CN1		(CN1) × 1
CON2	MR - J2CMP2		(CON2) × 1
HC - KFS < 750W A : A4 B : A3	HC - KFS053	50W	()
	HC - KFS13	100W	
	HC - KFS23	200W	
	HC - KFS43	400W	
	HC - KFS73	750W	
	HC - KFS053B	50W	
	HC - KFS13B	100W	
	HC - KFS23B	200W	
	HC - KFS43B	400W	
	HC - KFS73B	750W	
	HC - KFS053(B)G1 1/5	50W (1/5)	
	HC - KFS053(B)G1 1/12	50W (1/12)	
	HC - KFS053(B)G1 1/20	50W (1/20)	()
	HC - KFS13(B)G1 1/5	100W (1/5)	
	HC - KFS13(B)G1 1/12	100W (1/12)	
	HC - KFS13(B)G1 1/20	100W (1/20)	
	HC - KFS23(B)G1 1/5	200W (1/5)	
	HC - KFS23(B)G1 1/12	200W (1/12)	
	HC - KFS23(B)G1 1/20	200W (1/20)	
	HC - KFS43(B)G1 1/5	400W (1/5)	
	HC - KFS43(B)G1 1/12	400W (1/12)	
	HC - KFS43(B)G1 1/20	400W (1/20)	
	HC - KFS73(B)G1 1/5	750W (1/5)	
	HC - KFS73(B)G1 1/12	750W (1/12)	
	HC - KFS73(B)G1 1/20	750W (1/20)	()
	HC - KFS053(B)G2 1/5	50W (1/5)	
	HC - KFS053(B)G2 1/9	50W (1/9)	
	HC - KFS053(B)G2 1/20	50W (1/20)	
	HC - KFS053(B)G2 1/29	50W (1/29)	
	HC - KFS13(B)G2 1/5	100W (1/5)	
	HC - KFS13(B)G2 1/9	100W (1/9)	
	HC - KFS13(B)G2 1/20	100W (1/20)	
	HC - KFS13(B)G2 1/29	100W (1/29)	
	HC - KFS23(B)G2 1/5	200W (1/5)	
	HC - KFS23(B)G2 1/9	200W (1/9)	
	HC - KFS23(B)G2 1/20	200W (1/20)	
HC - KFS23(B)G2 1/29	200W (1/29)		
HC - KFS43(B)G2 1/5	400W (1/5)		
HC - KFS43(B)G2 1/9	400W (1/9)		
HC - KFS43(B)G2 1/20	400W (1/20)		
HC - KFS43(B)G2 1/29	400W (1/29)		
HC - KFS73(B)G2 1/5	750W (1/5)		
HC - KFS73(B)G2 1/9	750W (1/9)		
HC - KFS73(B)G2 1/20	750W (1/20)		
HC - KFS73(B)G2 1/29	750W (1/29)		

⋮

HC - KFS < 750W A : A4 B : A3	HC - KFS053(B)G5 1/5	50W (1/5)	()	
	HC - KFS053(B)G5 1/11	50W (1/11)		
	HC - KFS053(B)G5 1/21	50W (1/21)		
	HC - KFS053(B)G5 1/33	50W (1/33)		
	HC - KFS053(B)G5 1/45	50W (1/45)		
	HC - KFS13(B)G5 1/5	100W (1/5)		
	HC - KFS13(B)G5 1/11	100W (1/11)		
	HC - KFS13(B)G5 1/21	100W (1/21)		
	HC - KFS13(B)G5 1/33	100W (1/33)		
	HC - KFS13(B)G5 1/45	100W (1/45)		
	HC - KFS23(B)G5 1/5	200W (1/5)		
	HC - KFS23(B)G5 1/11	200W (1/11)		
	HC - KFS23(B)G5 1/21	200W (1/21)		
	HC - KFS23(B)G5 1/33	200W (1/33)		
	HC - KFS23(B)G5 1/45	200W (1/45)		
	HC - KFS43(B)G5 1/5	400W (1/5)		
	HC - KFS43(B)G5 1/11	400W (1/11)		
	HC - KFS43(B)G5 1/21	400W (1/21)		
	HC - KFS43(B)G5 1/33	400W (1/33)		
	HC - KFS43(B)G5 1/45	400W (1/45)		
	HC - KFS73(B)G5 1/5	750W (1/5)		
	HC - KFS73(B)G5 1/11	750W (1/11)		
	HC - KFS73(B)G5 1/21	750W (1/21)		
	HC - KFS73(B)G5 1/33	750W (1/33)		
	HC - KFS73(B)G5 1/45	750W (1/45)		
	HC - KFS053(B)G7 1/5	50W (1/5)		
	HC - KFS053(B)G7 1/11	50W (1/11)		
	HC - KFS053(B)G7 1/21	50W (1/21)		
	HC - KFS053(B)G7 1/33	50W (1/33)		
	HC - KFS053(B)G7 1/45	50W (1/45)		
	HC - KFS13(B)G7 1/5	100W (1/5)		
	HC - KFS13(B)G7 1/11	100W (1/11)		
	HC - KFS13(B)G7 1/21	100W (1/21)		
	HC - KFS13(B)G7 1/33	100W (1/33)		
	HC - KFS13(B)G7 1/45	100W (1/45)		
	HC - KFS23(B)G7 1/5	200W (1/5)		
	HC - KFS23(B)G7 1/11	200W (1/11)		
	HC - KFS23(B)G7 1/21	200W (1/21)		
	HC - KFS23(B)G7 1/33	200W (1/33)		
	HC - KFS23(B)G7 1/45	200W (1/45)		
	HC - KFS43(B)G7 1/5	400W (1/5)		
	HC - KFS43(B)G7 1/11	400W (1/11)		
	HC - KFS43(B)G7 1/21	400W (1/21)		
	HC - KFS43(B)G7 1/33	400W (1/33)		
	HC - KFS43(B)G7 1/45	400W (1/45)		
HC - KFS73(B)G7 1/5	750W (1/5)			
HC - KFS73(B)G7 1/11	750W (1/11)			
HC - KFS73(B)G7 1/21	750W (1/21)			
HC - KFS73(B)G7 1/33	750W (1/33)			
HC - KFS73(B)G7 1/45	750W (1/45)			
HC - KFS	HC - KFS46	400W	MR - J2S - 70 - U005	
	HC - KFS410		MR - J2S - 70 - U006	
HC - MFS	HC - MFS053	50W		
	HC - MFS13	100W		
	HC - MFS23	200W		
	HC - MFS43	400W		

⋮

HC - MFS	HC - MFS73	750W	()		
	HC - MFS053B	50W			
	HC - MFS13B	100W			
	HC - MFS23B	200W			
	HC - MFS43B	400W			
	HC - MFS73B	750W			
	HC - MFS053(B)G1 1/5	50W (1/5)	()		
	HC - MFS053(B)G1 1/12	50W (1/12)			
	HC - MFS053(B)G1 1/20	50W (1/20)			
	HC - MFS13(B)G1 1/5	100W (1/5)			
	HC - MFS13(B)G1 1/12	100W (1/12)			
	HC - MFS13(B)G1 1/20	100W (1/20)			
	HC - MFS23(B)G1 1/5	200W (1/5)			
	HC - MFS23(B)G1 1/12	200W (1/12)			
	HC - MFS23(B)G1 1/20	200W (1/20)			
	HC - MFS43(B)G1 1/5	400W (1/5)			
	HC - MFS43(B)G1 1/12	400W (1/12)			
	HC - MFS43(B)G1 1/20	400W (1/20)			
	HC - MFS73(B)G1 1/5	750W (1/5)			
	HC - MFS73(B)G1 1/12	750W (1/12)			
	HC - MFS73(B)G1 1/20	750W (1/20)			
	HC - MFS053(B)G2 1/5	50W (1/5)		()	
	HC - MFS053(B)G2 1/9	50W (1/9)			
	HC - MFS053(B)G2 1/20	50W (1/20)			
	HC - MFS053(B)G2 1/29	50W (1/29)			
	HC - MFS13(B)G2 1/5	100W (1/5)			
	HC - MFS13(B)G2 1/9	100W (1/9)			
	HC - MFS13(B)G2 1/20	100W (1/20)			
	HC - MFS13(B)G2 1/29	100W (1/29)			
	HC - MFS23(B)G2 1/5	200W (1/5)			
	HC - MFS23(B)G2 1/9	200W (1/9)			
	HC - MFS23(B)G2 1/20	200W (1/20)			
	HC - MFS23(B)G2 1/29	200W (1/29)			
	HC - MFS43(B)G2 1/5	400W (1/5)			
	HC - MFS43(B)G2 1/9	400W (1/9)			
	HC - MFS43(B)G2 1/20	400W (1/20)			
	HC - MFS43(B)G2 1/29	400W (1/29)			
	HC - MFS73(B)G2 1/5	750W (1/5)	()		
	HC - MFS73(B)G2 1/9	750W (1/9)			
	HC - MFS73(B)G2 1/20	750W (1/20)			
	HC - MFS73(B)G2 1/29	750W (1/29)			
	HC - MFS053(B)G5 1/5	50W (1/5)			
	HC - MFS053(B)G5 1/11	50W (1/11)			
	HC - MFS053(B)G5 1/21	50W (1/21)			
	HC - MFS053(B)G5 1/33	50W (1/33)			
	HC - MFS053(B)G5 1/45	50W (1/45)			
	HC - MFS13(B)G5 1/5	100W (1/5)			
	HC - MFS13(B)G5 1/11	100W (1/11)			
	HC - MFS13(B)G5 1/21	100W (1/21)			
	HC - MFS13(B)G5 1/33	100W (1/33)			
HC - MFS13(B)G5 1/45	100W (1/45)				
HC - MFS23(B)G5 1/5	200W (1/5)				
HC - MFS23(B)G5 1/11	200W (1/11)				

⋮

HC - MFS	HC - MFS23(B)G5 1/21	200W (1/21)	()		
	HC - MFS23(B)G5 1/33	200W (1/33)			
	HC - MFS23(B)G5 1/45	200W (1/45)			
	HC - MFS43(B)G5 1/5	400W (1/5)			
	HC - MFS43(B)G5 1/11	400W (1/11)			
	HC - MFS43(B)G5 1/21	400W (1/21)			
	HC - MFS43(B)G5 1/33	400W (1/33)			
	HC - MFS43(B)G5 1/45	400W (1/45)			
	HC - MFS73(B)G5 1/5	750W (1/5)			
	HC - MFS73(B)G5 1/11	750W (1/11)			
	HC - MFS73(B)G5 1/21	750W (1/21)			
	HC - MFS73(B)G5 1/33	750W (1/33)			
	HC - MFS73(B)G5 1/45	750W (1/45)			
	HC - MFS053(B)G7 1/5	50W (1/5)	()		
	HC - MFS053(B)G7 1/11	50W (1/11)			
	HC - MFS053(B)G7 1/21	50W (1/21)			
	HC - MFS053(B)G7 1/33	50W (1/33)			
	HC - MFS053(B)G7 1/45	50W (1/45)			
	HC - MFS13(B)G7 1/5	100W (1/5)			
	HC - MFS13(B)G7 1/11	100W (1/11)			
	HC - MFS13(B)G7 1/21	100W (1/21)			
	HC - MFS13(B)G7 1/33	100W (1/33)			
	HC - MFS13(B)G7 1/45	100W (1/45)			
	HC - MFS23(B)G7 1/5	200W (1/5)			
	HC - MFS23(B)G7 1/11	200W (1/11)			
	HC - MFS23(B)G7 1/21	200W (1/21)			
	HC - MFS23(B)G7 1/33	200W (1/33)			
	HC - MFS23(B)G7 1/45	200W (1/45)			
	HC - MFS43(B)G7 1/5	400W (1/5)			
	HC - MFS43(B)G7 1/11	400W (1/11)			
	HC - MFS43(B)G7 1/21	400W (1/21)			
	HC - MFS43(B)G7 1/33	400W (1/33)			
	HC - MFS43(B)G7 1/45	400W (1/45)			
	HC - MFS73(B)G7 1/5	750W (1/5)			
	HC - MFS73(B)G7 1/11	750W (1/11)			
	HC - MFS73(B)G7 1/21	750W (1/21)			
	HC - MFS73(B)G7 1/33	750W (1/33)			
	HC - MFS73(B)G7 1/45	750W (1/45)			
	HC - SFS1000r/min < A : A1 >	HC - SFS81	850W		
		HC - SFS121	1.2kW		
HC - SFS201		2kW			
HC - SFS301		3kW			
HC - SFS81B		850W			
HC - SFS121B		1.2kW			
HC - SFS201B		2kW			
HC - SFS301B		3kW			
HC - SFS2000r/min < 5.0kW, 7.0kW(200V) A : B0 B : B0 >	HC - SFS52	500W	200V		
	HC - SFS102	1kW			
	HC - SFS152	1.5kW			
	HC - SFS202	2kW			
	HC - SFS352	3.5kW	400V		
	HC - SFS502	5kW			
	HC - SFS702	7kW			
	HC - SFS524	500W			
HC - SFS1024	1kW				

⋮

MELSERVO J2 Super

HC - SFS2000r/min < 5.0kW, 7.0kW(200V) A : B0 B : B0	HC - SFS1524	1.5kW	400V	() G1 ... G1H ...
	HC - SFS2024	2kW		
	HC - SFS3524	3.5kW		
	HC - SFS5024	5kW		
	HC - SFS7024	7kW		
	HC - SFS52B	500W	200V	
	HC - SFS102B	1kW		
	HC - SFS152B	1.5kW		
	HC - SFS202B	2kW		
	HC - SFS352B	3.5kW		
	HC - SFS502B	5kW	400V	
	HC - SFS702B	7kW		
	HC - SFS524B	500W		
	HC - SFS1024B	1kW		
	HC - SFS1524B	1.5kW		
	HC - SFS2024B	2kW	200V	
	HC - SFS3524B	3.5kW		
	HC - SFS5024B	5kW		
	HC - SFS7024B	7kW		
	HC - SFS52(B)G1(H)1/6	500W (1/6)		
	HC - SFS52(B)G1(H)1/11	500W (1/11)		
	HC - SFS52(B)G1(H)1/17	500W (1/17)		
	HC - SFS52(B)G1(H)1/29	500W (1/29)		
	HC - SFS52(B)G1(H)1/35	500W (1/35)		
	HC - SFS52(B)G1(H)1/43	500W (1/43)		
	HC - SFS52(B)G1(H)1/59	500W (1/59)		
	HC - SFS102(B)G1(H)1/6	1kW (1/6)		
	HC - SFS102(B)G1(H)1/11	1kW (1/11)		
	HC - SFS102(B)G1(H)1/17	1kW (1/17)		
	HC - SFS102(B)G1(H)1/29	1kW (1/29)		
	HC - SFS102(B)G1(H)1/35	1kW (1/35)		
	HC - SFS102(B)G1(H)1/43	1kW (1/43)		
	HC - SFS102(B)G1(H)1/59	1kW (1/59)		
	HC - SFS152(B)G1(H)1/6	1.5kW (1/6)		
	HC - SFS152(B)G1(H)1/11	1.5kW (1/11)		
	HC - SFS152(B)G1(H)1/17	1.5kW (1/17)		
	HC - SFS152(B)G1(H)1/29	1.5kW (1/29)		
	HC - SFS152(B)G1(H)1/35	1.5kW (1/35)		
	HC - SFS152(B)G1(H)1/43	1.5kW (1/43)		
	HC - SFS152(B)G1(H)1/59	1.5kW (1/59)		
	HC - SFS202(B)G1(H)1/6	2kW (1/6)		
	HC - SFS202(B)G1(H)1/11	2kW (1/11)		
HC - SFS202(B)G1(H)1/17	2kW (1/17)			
HC - SFS202(B)G1(H)1/29	2kW (1/29)			
HC - SFS202(B)G1(H)1/35	2kW (1/35)			
HC - SFS202(B)G1(H)1/43	2kW (1/43)			
HC - SFS202(B)G1(H)1/59	2kW (1/59)			
HC - SFS352(B)G1(H)1/6	3.5kW (1/6)			
HC - SFS352(B)G1(H)1/11	3.5kW (1/11)			
HC - SFS352(B)G1(H)1/17	3.5kW (1/17)			
HC - SFS352(B)G1(H)1/29	3.5kW (1/29)			
HC - SFS352(B)G1(H)1/35	3.5kW (1/35)			

) G1(), G1H() 가 . :
:

HC - SFS2000r/min < 5.0kW, 7.0kW(200V) > A : B0 B : B0	HC - SFS352(B)G1(H)1/43	3.5kW (1/43)	200V	() G1 ... G1H ...
	HC - SFS352(B)G1(H)1/59	3.5kW (1/59)		
	HC - SFS502(B)G1(H)1/11	5kW (1/11)		
	HC - SFS502(B)G1(H)1/17	5kW (1/17)		
	HC - SFS502(B)G1(H)1/29	5kW (1/29)		
	HC - SFS502(B)G1(H)1/35	5kW (1/35)		
	HC - SFS502(B)G1(H)1/43	5kW (1/43)		
	HC - SFS702(B)G1(H)1/11	7kW (1/11)		
	HC - SFS702(B)G1(H)1/17	7kW (1/17)		
	HC - SFS702(B)G1(H)1/29	7kW (1/29)		
	HC - SFS702(B)G1(H)1/35	7kW (1/35)		
	HC - SFS702(B)G1(H)1/43	7kW (1/43)		
	HC - SFS524(B)G1(H)1/6	500W (1/6)	400V	
	HC - SFS524(B)G1(H)1/11	500W (1/11)		
	HC - SFS524(B)G1(H)1/17	500W (1/17)		
	HC - SFS524(B)G1(H)1/29	500W (1/29)		
	HC - SFS524(B)G1(H)1/35	500W (1/35)		
	HC - SFS524(B)G1(H)1/43	500W (1/43)		
	HC - SFS524(B)G1(H)1/59	500W (1/59)		
	HC - SFS1024(B)G1(H)1/6	1kW (1/6)		
	HC - SFS1024(B)G1(H)1/11	1kW (1/11)		
	HC - SFS1024(B)G1(H)1/17	1kW (1/17)		
	HC - SFS1024(B)G1(H)1/29	1kW (1/29)		
	HC - SFS1024(B)G1(H)1/35	1kW (1/35)		
	HC - SFS1024(B)G1(H)1/43	1kW (1/43)		
	HC - SFS1024(B)G1(H)1/59	1kW (1/59)		
	HC - SFS1524(B)G1(H)1/6	1.5kW (1/6)		
	HC - SFS1524(B)G1(H)1/11	1.5kW (1/11)		
	HC - SFS1524(B)G1(H)1/17	1.5kW (1/17)		
	HC - SFS1524(B)G1(H)1/29	1.5kW (1/29)		
	HC - SFS1524(B)G1(H)1/35	1.5kW (1/35)		
	HC - SFS1524(B)G1(H)1/43	1.5kW (1/43)		
	HC - SFS1524(B)G1(H)1/59	1.5kW (1/59)		
	HC - SFS2024(B)G1(H)1/6	2kW (1/6)		
	HC - SFS2024(B)G1(H)1/11	2kW (1/11)		
	HC - SFS2024(B)G1(H)1/17	2kW (1/17)		
	HC - SFS2024(B)G1(H)1/29	2kW (1/29)		
	HC - SFS2024(B)G1(H)1/35	2kW (1/35)		
	HC - SFS2024(B)G1(H)1/43	2kW (1/43)		
	HC - SFS2024(B)G1(H)1/59	2kW (1/59)		
	HC - SFS3524(B)G1(H)1/6	3.5kW (1/6)		
	HC - SFS3524(B)G1(H)1/11	3.5kW (1/11)		
	HC - SFS3524(B)G1(H)1/17	3.5kW (1/17)		
	HC - SFS3524(B)G1(H)1/29	3.5kW (1/29)		
	HC - SFS3524(B)G1(H)1/35	3.5kW (1/35)		
	HC - SFS3524(B)G1(H)1/43	3.5kW (1/43)		
	HC - SFS3524(B)G1(H)1/59	3.5kW (1/59)		
	HC - SFS5024(B)G1(H)1/11	5kW (1/11)		
	HC - SFS5024(B)G1(H)1/17	5kW (1/17)		
	HC - SFS5024(B)G1(H)1/29	5kW (1/29)		
HC - SFS5024(B)G1(H)1/35	5kW (1/35)			
HC - SFS5024(B)G1(H)1/43	5kW (1/43)			
HC - SFS7024(B)G1(H)1/11	7kW (1/11)			
HC - SFS7024(B)G1(H)1/17	7kW (1/17)			

) G1(), G1H() 가

:

MELSERVO J2 Super

HC - SFS2000r/min < 5.0kW, 7.0kW(200V) A : B0 B : B0	HC - SFS7024(B)G1(H)1/29	7kW (1/29)	400V	() G1... G1H...	
	HC - SFS7024(B)G1(H)1/35	7kW (1/35)			
	HC - SFS7024(B)G1(H)1/43	7kW (1/43)			
	HC - SFS52(B)G2 1/5	500W (1/5)	200V		
	HC - SFS52(B)G2 1/9	500W (1/9)			
	HC - SFS52(B)G2 1/20	500W (1/20)			
	HC - SFS52(B)G2 1/29	500W (1/29)			
	HC - SFS52(B)G2 1/45	500W (1/45)			
	HC - SFS102(B)G2 1/5	1kW (1/5)			
	HC - SFS102(B)G2 1/9	1kW (1/9)			
	HC - SFS102(B)G2 1/20	1kW (1/20)			
	HC - SFS102(B)G2 1/29	1kW (1/29)			
	HC - SFS102(B)G2 1/45	1kW (1/45)			
	HC - SFS152(B)G2 1/5	1.5kW (1/5)			
	HC - SFS152(B)G2 1/9	1.5kW (1/9)			
	HC - SFS152(B)G2 1/20	1.5kW (1/20)			
	HC - SFS152(B)G2 1/29	1.5kW (1/29)			
	HC - SFS152(B)G2 1/45	1.5kW (1/45)			
	HC - SFS202(B)G2 1/5	2kW (1/5)			
	HC - SFS202(B)G2 1/9	2kW (1/9)			
	HC - SFS202(B)G2 1/20	2kW (1/20)			
	HC - SFS202(B)G2 1/29	2kW (1/29)			
	HC - SFS202(B)G2 1/45	2kW (1/45)			
	HC - SFS352(B)G2 1/5	3.5kW (1/5)			
	HC - SFS352(B)G2 1/9	3.5kW (1/9)			
	HC - SFS352(B)G2 1/20	3.5kW (1/20)			
	HC - SFS502(B)G2 1/5	5kW (1/5)			
	HC - SFS502(B)G2 1/9	5kW (1/9)			
	HC - SFS702(B)G2 1/5	7kW (1/5)			
	HC - SFS524(B)G2 1/5	500W (1/5)			400V
	HC - SFS524(B)G2 1/9	500W (1/9)			
	HC - SFS524(B)G2 1/20	500W (1/20)			
	HC - SFS524(B)G2 1/29	500W (1/29)			
	HC - SFS524(B)G2 1/45	500W (1/45)			
	HC - SFS1024(B)G2 1/5	1kW (1/5)			
	HC - SFS1024(B)G2 1/9	1kW (1/9)			
	HC - SFS1024(B)G2 1/20	1kW (1/20)			
	HC - SFS1024(B)G2 1/29	1kW (1/29)			
	HC - SFS1024(B)G2 1/45	1kW (1/45)			
	HC - SFS1524(B)G2 1/5	1.5kW (1/5)			
HC - SFS1524(B)G2 1/9	1.5kW (1/9)				
HC - SFS1524(B)G2 1/20	1.5kW (1/20)				
HC - SFS1524(B)G2 1/29	1.5kW (1/29)				
HC - SFS1524(B)G2 1/45	1.5kW (1/45)				
HC - SFS2024(B)G2 1/5	2kW (1/5)				
HC - SFS2024(B)G2 1/9	2kW (1/9)				
HC - SFS2024(B)G2 1/20	2kW (1/20)				
HC - SFS2024(B)G2 1/29	2kW (1/29)				
HC - SFS2024(B)G2 1/45	2kW (1/45)				
HC - SFS3524(B)G2 1/5	3.5kW (1/5)				
HC - SFS3524(B)G2 1/9	3.5kW (1/9)				
HC - SFS3524(B)G2 1/20	3.5kW (1/20)				
HC - SFS5024(B)G2 1/5	5kW (1/5)				
HC - SFS5024(B)G2 1/9	5kW (1/9)				
HC - SFS7024(B)G2 1/5	7kW (1/5)				

) G1(), G1H() 가 . :
:

HC - SFS2000r/min < 5.0kW, 7.0kW(200V) > A : B0 B : B0	HC - SFS52(B)G5 1/5	500W (1/5)	200V	()
	HC - SFS52(B)G5 1/11	500W (1/11)		
	HC - SFS52(B)G5 1/21	500W (1/21)		
	HC - SFS52(B)G5 1/33	500W (1/33)		
	HC - SFS52(B)G5 1/45	500W (1/45)		
	HC - SFS102(B)G5 1/5	1kW (1/5)		
	HC - SFS102(B)G5 1/11	1kW (1/11)		
	HC - SFS102(B)G5 1/21	1kW (1/21)		
	HC - SFS102(B)G5 1/33	1kW (1/33)		
	HC - SFS102(B)G5 1/45	1kW (1/45)		
	HC - SFS152(B)G5 1/5	1.5kW (1/5)		
	HC - SFS152(B)G5 1/11	1.5kW (1/11)		
	HC - SFS152(B)G5 1/21	1.5kW (1/21)		
	HC - SFS152(B)G5 1/33	1.5kW (1/33)		
	HC - SFS152(B)G5 1/45	1.5kW (1/45)		
	HC - SFS202(B)G5 1/5	2kW (1/5)		
	HC - SFS202(B)G5 1/11	2kW (1/11)		
	HC - SFS202(B)G5 1/21	2kW (1/21)		
	HC - SFS202(B)G5 1/33	2kW (1/33)		
	HC - SFS202(B)G5 1/45	2kW (1/45)		
	HC - SFS352(B)G5 1/5	3.5kW (1/5)		
	HC - SFS352(B)G5 1/11	3.5kW (1/11)		
	HC - SFS352(B)G5 1/21	3.5kW (1/21)		
	HC - SFS502(B)G5 1/5	5kW (1/5)		
	HC - SFS502(B)G5 1/11	5kW (1/11)		
	HC - SFS702(B)G5 1/5	7kW (1/5)		
	HC - SFS524(B)G5 1/5	500W (1/5)	400V	
	HC - SFS524(B)G5 1/11	500W (1/11)		
	HC - SFS524(B)G5 1/21	500W (1/21)		
	HC - SFS524(B)G5 1/33	500W (1/33)		
	HC - SFS524(B)G5 1/45	500W (1/45)		
	HC - SFS1024(B)G5 1/5	1kW (1/5)		
	HC - SFS1024(B)G5 1/11	1kW (1/11)		
	HC - SFS1024(B)G5 1/21	1kW (1/21)		
	HC - SFS1024(B)G5 1/33	1kW (1/33)		
	HC - SFS1024(B)G5 1/45	1kW (1/45)		
	HC - SFS1524(B)G5 1/5	1.5kW (1/5)		
	HC - SFS1524(B)G5 1/11	1.5kW (1/11)		
	HC - SFS1524(B)G5 1/21	1.5kW (1/21)		
	HC - SFS1524(B)G5 1/33	1.5kW (1/33)		
	HC - SFS1524(B)G5 1/45	1.5kW (1/45)		
	HC - SFS2024(B)G5 1/5	2kW (1/5)		
	HC - SFS2024(B)G5 1/11	2kW (1/11)		
	HC - SFS2024(B)G5 1/21	2kW (1/21)		
	HC - SFS2024(B)G5 1/33	2kW (1/33)		
	HC - SFS2024(B)G5 1/45	2kW (1/45)		
	HC - SFS3524(B)G5 1/5	3.5kW (1/5)		
	HC - SFS3524(B)G5 1/11	3.5kW (1/11)		
	HC - SFS3524(B)G5 1/21	3.5kW (1/21)		
	HC - SFS5024(B)G5 1/5	5kW (1/5)		
HC - SFS5024(B)G5 1/11	5kW (1/11)			
HC - SFS7024(B)G5 1/5	7kW (1/5)			
HC - SFS52(B)G7 1/5	500W (1/5)	200V		
HC - SFS52(B)G7 1/11	500W (1/11)			
HC - SFS52(B)G7 1/21	500W (1/21)			
HC - SFS52(B)G7 1/33	500W (1/33)			
HC - SFS52(B)G7 1/45	500W (1/45)			

⋮

HC - SFS2000r/min < > 5.0kW, 7.0kW(200V) A : B0 B : B0	HC - SFS102(B)G7 1/5	1kW (1/5)	200V	()
	HC - SFS102(B)G7 1/11	1kW (1/11)		
	HC - SFS102(B)G7 1/21	1kW (1/21)		
	HC - SFS102(B)G7 1/33	1kW (1/33)		
	HC - SFS102(B)G7 1/45	1kW (1/45)		
	HC - SFS152(B)G7 1/5	1.5kW (1/5)		
	HC - SFS152(B)G7 1/11	1.5kW (1/11)		
	HC - SFS152(B)G7 1/21	1.5kW (1/21)		
	HC - SFS152(B)G7 1/33	1.5kW (1/33)		
	HC - SFS152(B)G7 1/45	1.5kW (1/45)		
	HC - SFS202(B)G7 1/5	2kW (1/5)		
	HC - SFS202(B)G7 1/11	2kW (1/11)		
	HC - SFS202(B)G7 1/21	2kW (1/21)		
	HC - SFS202(B)G7 1/33	2kW (1/33)		
	HC - SFS202(B)G7 1/45	2kW (1/45)		
	HC - SFS352(B)G7 1/5	3.5kW (1/5)		
	HC - SFS352(B)G7 1/11	3.5kW (1/11)		
	HC - SFS352(B)G7 1/21	3.5kW (1/21)		
	HC - SFS502(B)G7 1/5	5kW (1/5)		
	HC - SFS502(B)G7 1/11	5kW (1/11)		
	HC - SFS702(B)G7 1/5	7kW (1/5)		
	HC - SFS524(B)G7 1/5	500W (1/5)	400V	
	HC - SFS524(B)G7 1/11	500W (1/11)		
	HC - SFS524(B)G7 1/21	500W (1/21)		
	HC - SFS524(B)G7 1/33	500W (1/33)		
	HC - SFS524(B)G7 1/45	500W (1/45)		
	HC - SFS1024(B)G7 1/5	1kW (1/5)		
	HC - SFS1024(B)G7 1/11	1kW (1/11)		
	HC - SFS1024(B)G7 1/21	1kW (1/21)		
	HC - SFS1024(B)G7 1/33	1kW (1/33)		
	HC - SFS1024(B)G7 1/45	1kW (1/45)		
	HC - SFS1524(B)G7 1/5	1.5kW (1/5)		
	HC - SFS1524(B)G7 1/11	1.5kW (1/11)		
	HC - SFS1524(B)G7 1/21	1.5kW (1/21)		
	HC - SFS1524(B)G7 1/33	1.5kW (1/33)		
	HC - SFS1524(B)G7 1/45	1.5kW (1/45)		
	HC - SFS2024(B)G7 1/5	2kW (1/5)		
	HC - SFS2024(B)G7 1/11	2kW (1/11)		
	HC - SFS2024(B)G7 1/21	2kW (1/21)		
	HC - SFS2024(B)G7 1/33	2kW (1/33)		
HC - SFS2024(B)G7 1/45	2kW (1/45)			
HC - SFS3524(B)G7 1/5	3.5kW (1/5)			
HC - SFS3524(B)G7 1/11	3.5kW (1/11)			
HC - SFS3524(B)G7 1/21	3.5kW (1/21)			
HC - SFS5024(B)G7 1/5	5kW (1/5)			
HC - SFS5024(B)G7 1/11	5kW (1/11)			
HC - SFS7024(B)G7 1/5	7kW (1/5)			
HC - SFS3000r/min < > A : A1	HC - SFS53	500W		
	HC - SFS103	1kW		
	HC - SFS153	1.5kW		
	HC - SFS203	2kW		
	HC - SFS353	3.5kW		
	HC - SFS53B	500W		
	HC - SFS103B	1kW		
	HC - SFS153B	1.5kW		
	HC - SFS203B	2kW		
	HC - SFS353B	3.5kW		

⋮

HC - LFS2000r/min < > A : B3 B : B3 CP : A2	HC - LFS52	500W		
	HC - LFS102	1kW		
	HC - LFS152	1.5kW		
	HC - LFS202	2kW		
	HC - LFS302	3kW		
	HC - LFS52B	500W		
	HC - LFS102B	1kW		
	HC - LFS152B	1.5kW		
	HC - LFS202B	2kW		
	HC - LFS302B	3kW		
HC - RFS2000r/min < > 3.5kW, 5.0kW A : B0 B : B0	HC - RFS103	1kW	()	
	HC - RFS153	1.5kW		
	HC - RFS203	2kW		
	HC - RFS353	3.5kW		
	HC - RFS503	5kW		
	HC - RFS103B	1kW		
	HC - RFS153B	1.5kW		
	HC - RFS203B	2kW		
	HC - RFS353B	3.5kW		
	HC - RFS503B	5kW		
	HC - RFS103(B)G2 1/5	1kW (1/5)		
	HC - RFS103(B)G2 1/9	1kW (1/9)		
	HC - RFS103(B)G2 1/20	1kW (1/20)		
	HC - RFS103(B)G2 1/29	1kW (1/29)		
	HC - RFS103(B)G2 1/45	1kW (1/45)		
	HC - RFS153(B)G2 1/5	1.5kW (1/5)		
	HC - RFS153(B)G2 1/9	1.5kW (1/9)		
	HC - RFS153(B)G2 1/20	1.5kW (1/20)		
	HC - RFS153(B)G2 1/29	1.5kW (1/29)		
	HC - RFS153(B)G2 1/45	1.5kW (1/45)		
	HC - RFS203(B)G2 1/5	2kW (1/5)		
	HC - RFS203(B)G2 1/9	2kW (1/9)		
	HC - RFS203(B)G2 1/20	2kW (1/20)		
	HC - RFS203(B)G2 1/29	2kW (1/29)		
	HC - RFS203(B)G2 1/45	2kW (1/45)		
	HC - RFS353(B)G2 1/5	3.5kW (1/5)		
	HC - RFS353(B)G2 1/9	3.5kW (1/9)		
	HC - RFS353(B)G2 1/20	3.5kW (1/20)		
	HC - RFS353(B)G2 1/29	3.5kW (1/29)		
	HC - RFS353(B)G2 1/45	3.5kW (1/45)		
	HC - RFS503(B)G2 1/5	5kW (1/5)		
	HC - RFS503(B)G2 1/9	5kW (1/9)		
	HC - RFS503(B)G2 1/20	5kW (1/20)		
	HC - RFS103(B)G5 1/5	1kW (1/5)		
	HC - RFS103(B)G5 1/11	1kW (1/11)		
	HC - RFS103(B)G5 1/21	1kW (1/21)		
	HC - RFS103(B)G5 1/33	1kW (1/33)		
	HC - RFS103(B)G5 1/45	1kW (1/45)		
	HC - RFS153(B)G5 1/5	1.5kW (1/5)		
	HC - RFS153(B)G5 1/11	1.5kW (1/11)		
HC - RFS153(B)G5 1/21	1.5kW (1/21)			
HC - RFS153(B)G5 1/33	1.5kW (1/33)			
HC - RFS153(B)G5 1/45	1.5kW (1/45)			
HC - RFS203(B)G5 1/5	2kW (1/5)			
HC - RFS203(B)G5 1/11	2kW (1/11)			
HC - RFS203(B)G5 1/21	2kW (1/21)			
HC - RFS203(B)G5 1/33	2kW (1/33)			
HC - RFS203(B)G5 1/45	2kW (1/45)			

⋮

HC - RFS2000r/min < > 3.5kW, 5.0kW A : B0 B : B0	HC - RFS353(B)G5 1/5	3.5kW (1/5)	()		
	HC - RFS353(B)G5 1/11	3.5kW (1/11)			
	HC - RFS353(B)G5 1/21	3.5kW (1/21)			
	HC - RFS353(B)G5 1/33	3.5kW (1/33)			
	HC - RFS503(B)G5 1/5	5kW (1/5)			
	HC - RFS503(B)G5 1/11	5kW (1/11)			
	HC - RFS503(B)G5 1/21	5kW (1/21)			
	HC - RFS103(B)G7 1/5	1kW (1/5)		()	
	HC - RFS103(B)G7 1/11	1kW (1/11)			
	HC - RFS103(B)G7 1/21	1kW (1/21)			
	HC - RFS103(B)G7 1/33	1kW (1/33)			
	HC - RFS103(B)G7 1/45	1kW (1/45)			
	HC - RFS153(B)G7 1/5	1.5kW (1/5)			
	HC - RFS153(B)G7 1/11	1.5kW (1/11)			
	HC - RFS153(B)G7 1/21	1.5kW (1/21)			
	HC - RFS153(B)G7 1/33	1.5kW (1/33)			
	HC - RFS153(B)G7 1/45	1.5kW (1/45)			
	HC - RFS203(B)G7 1/5	2kW (1/5)			
	HC - RFS203(B)G7 1/11	2kW (1/11)			
	HC - RFS203(B)G7 1/21	2kW (1/21)			
	HC - RFS203(B)G7 1/33	2kW (1/33)			
	HC - RFS203(B)G7 1/45	2kW (1/45)			
	HC - RFS353(B)G7 1/5	3.5kW (1/5)			
	HC - RFS353(B)G7 1/11	3.5kW (1/11)			
	HC - RFS353(B)G7 1/21	3.5kW (1/21)			
	HC - RFS353(B)G7 1/33	3.5kW (1/33)			
	HC - RFS503(B)G7 1/5	5kW (1/5)			
	HC - RFS503(B)G7 1/11	5kW (1/11)			
HC - RFS503(B)G7 1/21	5kW (1/21)				
HA - LFS1000r/min < > 6kW(200V) A : B5 B : B4 25kW, 30kW(200V) A : A2 B : A5 37kW(200V) A : B1 B : B1 37kW(400V) A : B1 B : B1 A : A0 B : A3 < > 6kW(400V) : MR - J2S - 700 4 - U071 8kW(400V) : MR - J2S - 11K 4 - U061 12kW(400V) : MR - J2S - 11K 4 - U062 15kW(400V) : MR - J2S - 15K 4 - U063 20kW(400V) : MR - J2S - 22K 4 - U064 25kW(400V) : MR - J2S - 30K 4 - U065	HA - LFS601	6kW	200V		
	HA - LFS801	8kW			
	HA - LFS12K1	12kW			
	HA - LFS15K1	15kW			
	HA - LFS20K1	20kW			
	HA - LFS25K1	25kW			
	HA - LFS30K1	30kW			
	HA - LFS37K1	37kW			
	HA - LFS6014 (1)	6kW		400V	
	HA - LFS8014 (1)	8kW			
	HA - LFS12K14 (1)	12kW			
	HA - LFS15K14	15kW			
	HA - LFS20K14 (1)	20kW			
	HA - LFS25K14 (1)	25kW			
	HA - LFS30K14	30kW			
	HA - LFS37K14	37kW			
	HA - LFS601B	6kW	200V		
	HA - LFS801B	8kW			
	HA - LFS12K1B	12kW	400V		
	HA - LFS6014B (1)	6kW			
HA - LFS8014B (1)	8kW				
HA - LFS12K14B (1)	12kW				
HA - LFS1500r/min < > 7kW(200V) A : B6 B : A5 11kW, 15kW, 22kW, 30kW(200V) A : A0 B : A3 37kW(200V) A : A3 B : B0	HA - LFS701M (1)	7kW	200V		
	HA - LFS11K1M	11kW			
	HA - LFS15K1M	15kW			
	HA - LFS22K1M	22kW			
	HA - LFS30K1M	30kW			
	HA - LFS37K1M	37kW			

HA - LFS1500r/min < > 11kW(400V) A : A0 B : A4 22kW, 30kW(400V) A : A2 B : A5 45kW(400V) A : A1 B : A4 A : A0 B : A3 < > 7kW(400V) : MR-J2S-700 4-U073	HA - LFS701M4 (1)	7kW	400V		
	HA - LFS11K1M4	11kW			
	HA - LFS15K1M4	15kW			
	HA - LFS22K1M4	22kW			
	HA - LFS30K1M4	30kW			
	HA - LFS37K1M4	37kW			
	HA - LFS45K1M4	45kW	200V		
	HA - LFS50K1M4	50kW			
	HA - LFS701MB (1)	7kW			
	HA - LFS11K1MB	11kW	400V		
	HA - LFS15K1MB	15kW			
	HA - LFS701M4B (1)	7kW			
HA - LFS11K1M4B	11kW				
HA - LFS15K1M4B	15kW				
HA - LFS2000r/min < > A ,B : B0	HA - LFS502	5kW	200V		
	HA - LFS702	7kW			
HA - LFS2000r/min < > 15kW(400V) A : A3 B : A6 A : A0 B : A3	HA - LFS11K2	11kW	200V		
	HA - LFS15K2	15kW			
	HA - LFS22K2	22kW			
	HA - LFS30K2	30kW			
	HA - LFS37K2	37kW			
	HA - LFS11K24	11kW			
	HA - LFS15K24	15kW			
	HA - LFS22K24	22kW			
	HA - LFS30K24	30kW			
	HA - LFS37K24	37kW			
	HA - LFS45K24	45kW			
	HA - LFS55K24	55kW	200V		
	HA - LFS11K2B	11kW			
	HA - LFS15K2B	15kW			
	HA - LFS22K2B	22kW	400V		
	HA - LFS11K24B	11kW			
	HA - LFS15K24B	15kW			
	HA - LFS22K24B	22kW			
HC - UFS2000r/min < > 3.5kW, 5.0kW A : B0 B : B0	HC - UFS72	750W			
	HC - UFS152	1.5kW			
	HC - UFS202	2kW			
	HC - UFS352	3.5kW			
	HC - UFS502	5kW			
	HC - UFS72B	750W			
	HC - UFS152B	1.5kW			
	HC - UFS202B	2kW			
	HC - UFS352B	3.5kW			
	HC - UFS502B	5kW			
	HC - UFS3000r/min	HC - UFS13			
HC - UFS23		200W			
HC - UFS43		400W			
HC - UFS73		750W			
HC - UFS13B		100W			
HC - UFS23B		200W			
HC - UFS43B		400W			
HC - UFS73B		750W			
HC - UFS13(B) - S1		100W			
HC - UFS23(B) - S1		200W			
HC - UFS43(B) - S1		400W			
HC - UFS73(B) - S1	750W				
	MR - JACN15K	MR - J2S - 11K (4),MR - J2S - 15K (4)			

MELSERVO J2 Super

	MR - JACN22K	MR - J2S - 22K (4)	
	MR - ACNP55K	MR - HP30KA, MR - HP55KA4	
	MR - ACN30K	MR - J2S - 30K 4	
	MR - ACN55K	MR - J2S - 30K , 37K , 37K 4, 45K 4, 55K 4	
	MR - BAT		
	MR - HDP01	MR - J2S - CP MR - J2S - CL	
	MR - DP60	7 LED 6 , MR - J2S - CP MR - J2S - CL	
	MR - RB032	30W, 40	200V
	MR - RB12	100W, 40	
	MR - RB30	300W, 13	
	MR - RB31	300W, 6.7	
	MR - RB32	300W, 40	
	MR - RB50	500W, 13	
	MR - RB51	500W, 6.7	
	MR - RB65	500(800)W, 8	
	MR - RB66	850(1300)W, 5	
	MR - RB67	850(1300)W, 4	
	MR - RB139	1300W, 1.3	400V
	MR - RB137	3900W, 1.3 (3 1 . 1 3 .)	
	MR - RB1L - 4	100W, 270	
	MR - RB3M - 4	300W, 120	
	MR - RB3H - 4	300W, 80	
	MR - RB3G - 4	300W, 47	
	MR - RB34 - 4	300W, 26	
	MR - RB5H - 4	500W, 80	
	MR - RB5G - 4	500W, 47	
	MR - RB54 - 4	500W, 26	
MR - RB6B - 4	500(800)W, 20		
MR - RB60 - 4	850(1300)W, 12.5		
MR - RB6K - 4	850(1300)W, 10		
MR - RB136 - 4	1300W, 5		
MR - RB138 - 4	3900W, 5 (3 1 . 1 3 .)		
	DBU - 11K	MR - J2S - 11K	
	DBU - 15K	MR - J2S - 15K	
	DBU - 22K	MR - J2S - 22K	
	DBU - 37K	MR - J2S - 30K , 37K	
	DBU - 11K - 4	MR - J2S - 11K 4	
	DBU - 22K - 4	MR - J2S - 15K 4, MR - J2S - 22K 4	
	DBU - 55K - 4	MR - J2S - 30K 4, 37K 4, 45K 4, 55K 4	
	MR - DCL30K	MR - J2S - 30K	
	MR - DCL37K	MR - J2S - 37K	
	MR - DCL30K - 4	MR - J2S - 30K 4	
	MR - DCL37K - 4	MR - J2S - 37K 4	
	MR - DCL45K - 4	MR - J2S - 45K 4	
	MR - DCL55K - 4	MR - J2S - 55K 4	
MR Configurator (-)	MRZJW3 - SETUP161	- (1)	
	MR - J2LL	TE2 L1, L2 .1 10	

) 1. -SETUP111 MR - J2S - B , -SETUP121 5,7kW -SETUP141 MR - J2S - CP
 MR - J2S - 11KB - 37KB -SETUP151 E1
 MR - J2S - 11KA - 37KA MR - J2S - 11KA4 - 55KA4 -SETUP151 E2
 MR - J2S - 60A4 - 700A4 MR - J2S - 60B4 - 55KB4 -SETUP161
 MR - J2S - CP - S084 MR - J2S - CL -SETUP161

(MR-J2)

<MR-J2S- A>



		MR-J2S- A	MR-J2- A
/		MR-J2- A /MR-J2- A	-
		AC100V : 0.05~0.4kW AC200V : 0.05~37kW AC400V : 0.5~55kW	AC100V : 0.05~0.4kW AC200V : 0.05~3.5kW AC400V : -
		MR-J2- A () .RS-422 가	-
LED /		5 1 2 3 4 5 / 4	4 1 2 3 4 / 4
		RS-232C RS-422	RS-232C
		500kpps()	400kpps()

<MR-J2S- B>

		MR-J2S- B	MR-J2- B
/		MR-J2- B /MR-J2- B	-
		AC100V : 0.05~0.4kW AC200V : 0.05~37kW AC400V : 0.5~55kW	AC100V : - AC200V : 0.05~3.5kW AC400V : -
		MR-J2- B () . (ABZ) 가	-

<MR-J2S- CP>

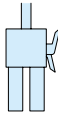
		MR-J2S- CP	MR-J2- C
/		MR-J2- C /MR-J2- C	-
		AC100V : 0.05~0.4kW AC200V : 0.05~7kW	AC100V : - AC200V : 0.05~3.5kW
		MR-J2- C ()	-
LED /		5 1 2 3 4 5 / 4	4 1 2 3 4 / 4
		MR-J2- C	-
		CC-Link	-

		HC- S, HA-LFS	HC-
/		ABS 17bit(131072 p/rev)	ABS 13bit(8192 p/rev), 14bit(16384 p/rev)
		 <HC-KFS, MFS, UFS 3000r/min> () 5557-04R-210(,) 5557-06R-210(,) 5556PBT(凹)	 <(HC-KF, MF, UF 3000r/min)> ,
		AC200V : 0.05~37kW AC400V : 0.5~55kW	AC200V : 0.05~3.5kW
		HC-KFS, MFS, SFS, RFS : G5, G7 가	-
		HC-KFS, MFS : IP55 (IP65) ()	HC-KF, MF : IP44 (IP65) ()

) IP65

50W

MR-J2S

(HC- S

HA-LFS

)

MR-J2

MR-J2

MELSERVO J2 Super

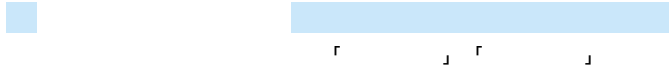

가
가



2004 1 가 가 (가)
가 가
가 가
(FR-BAL FR-BEL)

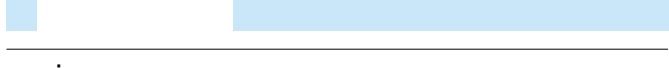

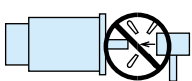
가 가
가 가
가 가

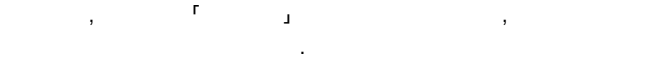

10mm
MR-J2S-30K (4) 20mm
100mm 120mm
1 40mm 120mm

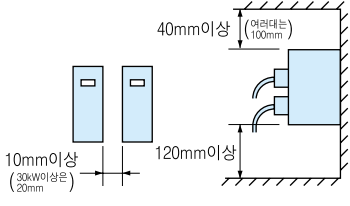

가 가
가 가

(100)

가가

가

가 가

3
1

가

(U, V, W) 가 가
(U, V, W) 가 가
(U, V, W) (U, V, W)

(LSP, LSN)
(SG)

MR-J2S-A No.0
MR-J2S-B
MR-J2S-CP 22kW MR-J2S-CL No.0(MR-J2S-A No.2(MR-J2S-B))

1 (MC) MC

7kW

11kW 가 가

K(-4) DBU-

OFF ON

가 가

(ts)

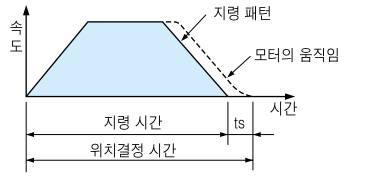

A series of horizontal dashed lines for writing.



● **상해 FA센터**

• MITSUBISHI ELECTRIC AUTOMATION(SHANGHAI) LTD.
80 Xin Chang Road, 4th Floor,
Shanghai Intelligence Fortune Leisure Plaza
Huang Pu district, Shanghai 200003, China
Tel : 86-21-6121-2460 Fax : 86-21-6121-2424

● **북경 FA센터**

• MITSUBISHI ELECTRIC AUTOMATION(SHANGHAI) LTD.
BEIJING OFFICE
Unit 917/918, 9/F Office Tower 1,
Henderson Center, 18 Jianguomennei Dajie,
Dongcheng District, Beijing 100005, China
Tel : 86-10-6518-8830 Fax : 86-10-6518-8030

● **천진 FA센터**

• MITSUBISHI ELECTRIC AUTOMATION(SHANGHAI) LTD.
TIANJIN OFFICE
B-2 801/802 Youyi Building,
No.50 Youyi Road, Hexi District,
Tianjin 300061, China
Tel : 86-22-2813-1015 Fax : 86-22-2813-1017

● **홍콩 FA센터**

• MITSUBISHI ELECTRIC AUTOMATION(HONG KONG) LTD. (FA DIVISION)
10th Floor, Manulife Tower, 169 Electric Road,
North Point, Hong Kong
Tel : 852-2887-8870 Fax : 852-2887-7984

● **대만 FA센터**

• SETSUYO ENTERPRISE CO., LTD.
6F No.105 Wu Kung 3rd RD, Wu-Ku Hsiang,
Taipei Hsien, Taiwan
Tel : 886-2-2299-2499 Fax : 886-2-2299-2509

● **한국 FA센터**

• MITSUBISHI ELECTRIC AUTOMATION KOREA CO., LTD.
1480-6 Gayang-dong, Gangseo-gu, Seoul 157-200, Korea
Tel : 82-2-3660-9607 Fax : 82-2-3663-0475

● **태국 FA센터**

• MITSUBISHI ELECTRIC AUTOMATION THAILAND CO., LTD.
Bang-Chan Industrial Estate No.111
Moo4, Serithai Road, T.kannayao A.kannayao
Bangkok 10230, Thailand

● **아세안 FA센터**

• MITSUBISHI ELECTRIC ASIA PTE, LTD.
307 Alexandra Road #05-01/02
Mitsubishi Electric Building, Singapore 159943
Tel : 65-6470-2480 Fax : 65-6476-7439

● **북미 FA센터**

• MITSUBISHI ELECTRIC AUTOMATION, INC.
500 Corporate Woods Parkway, Vernon Hills, IL 60061, USA
Tel : 1-847-478-2330 Fax : 1-847-478-2396

● **유럽 FA센터**

• MITSUBISHI ELECTRIC EUROPE B.V. GERMAN BRANCH
Gothaer Strasse 8 D-40880 Ratingen, GERMANY
Tel : 49-2102-486-2630 Fax : 49-2102-486-7170

● **영국 FA센터**

• MITSUBISHI ELECTRIC EUROPE B.V. UK BRANCH
(Customer Technology Centre)
Travellers Lane, Hatfield, Hertfordshire, AL10 8XB, U.K.
Tel : 44-1707-278843 Fax : 44-1707-278992



본 사: 157-200 서울특별시 강서구 가양동 1480-6
TEL. 02)3660-9515~19 FAX. 02)3664-8372/8335

부산영업소: 617-726 부산광역시 사상구 과법동 578
산업용품유통상가 업무동 206호
TEL. 051)319-3747 FAX. 051)319-3768

대구영업소: 702-845 대구광역시 북구 산격2동 1666
종합유통단지 전기조명관 업무동 603호
TEL. 053)604-6047 FAX. 053)604-6049

F.A 센터: 서울특별시 강서구 가양동 1480-6 2F
TEL. 02)3660-9607 FAX. 02)3663-0475

<http://www.mitsubishi-automation.co.kr>

