

# **mitsubishi**

**General-Purpose AC Servo**

# **MELSERVO-H Series**

**Positioning function built-in**

**MR-H□ACN**

**Servo Amplifier**

**Instruction Manual**

# ● Safety Instructions ●

(Always read these instructions before using the equipment.)

Do not attempt to install, operate, maintain or inspect the controller and servo motor until you have read through this Instruction Manual, Installation guide, Servo motor Instruction Manual and appended documents carefully and can use the equipment correctly. Do not use the controller and servo motor until you have a full knowledge of the equipment, safety information and instructions.

In this Instruction Manual, the safety instruction levels are classified into "WARNING" and "CAUTION".





Indicates that incorrect handling may cause hazardous conditions,, resulting in death or severe injury.





Indicates that incorrect handling may cause hazardous conditions,, resulting in medium or slight injury to personnel or may cause physical damage.

Note that the CAUTION level may lead to a serious consequence according to conditions. Please follow the instructions of both levels because they are important to personnel safety.

What must not be done and what must be done are indicated by the following diagrammatic symbols:

 : Indicates what must not be done. For example, "No Fire" is indicated by .

 : Indicates what must be done. For example, grounding is indicated by .

In this Instruction Manual, instructions at a lower level than the above, instructions for other functions, and so on are classified into "POINT".

After reading this installation guide, always keep it accessible to the operator.

1. To prevent electric shock, note the following:

 CAUTION

- Before wiring or inspection, switch power off and wait for more than 10 minutes. Then, confirm the voltage is safe with voltage tester. Otherwise, you may get an electric shock.
- Connect the controller and servo motor to ground.
- Any person who is involved in wiring and inspection should be fully competent to do the work.
- Do not attempt to wire the controller and servo motor until they have been installed. Otherwise, you may get an electric shock.
- Operate the switches with dry hand to prevent an electric shock.
- The cables should not be damaged, stressed loaded,, or pinched. Otherwise, you may get an electric shock.
- During power-on or operation, do not open the front cover. You may get an electric shock.
- Do not operate the controller with the front cover removed. High-voltage terminals and charging area are exposed and you may get an electric shock.
- Except for wiring or periodic inspection, do not remove the front cover even if the power is off. The controller is charged and you may get an electric shock.

2. To prevent fire, note the following:

 CAUTION

- Do not install the controller, servo motor and regenerative brake resistor on or near combustibles. Otherwise a fire may cause.
- When the controller has become faulty, switch off the main controller power side. Continuous flow of a large current may cause a fire.
- When a regenerative brake resistor is used, use an alarm signal to switch main power off. Otherwise, a regenerative brake transistor fault or the like may overheat the regenerative brake resistor, causing a fire.

3. To prevent injury, note the follow

 CAUTION

- Only the voltage specified in the Instruction Manual should be applied to each terminal,, Otherwise,, a burst,, damage,, etc. may occur.
- Connect the terminals correctly to prevent a burst,, damage,, etc.
- Ensure that polarity (+, -) is correct. Otherwise, a burst, damage, etc. may occur.
- During power-on or for some time after power-off, do not touch the controller fins, regenerative brake resistor, servo motor, etc. Their temperatures may be high and you may get burnt.

#### 4. Additional instructions

The following instructions should also be fully noted. Incorrect handling may cause a fault, injury, electric shock, etc.

##### (1) Transportation and installation

## ⚠ CAUTION

- Transport the products correctly according to their weights.
- Use the eye-bolt of the servo motor to only transport the servo motor and do not use it to transport in the condition to have installed a servo motor on the machine.
- Stacking in excess of the specified number of products is not allowed.
- Do not carry the motor by the cables, shaft or encoder.
- Do not hold the front cover to transport the controller. The controller may drop.
- Install the controller in a load-bearing place in accordance with the Instruction Manual.
- Do not climb or stand on servo equipment. Do not put heavy objects on equipment.
- The controller and servo motor must be installed in the specified direction.
- Leave specified clearances between the controller and control enclosure walls or other equipment.
- Do not install or operate the controller and servo motor which has been damaged or has any parts missing.
- Do not block the intake/exhaust port of the servo motor which has a cooling fan.
- Provide adequate protection to prevent screws and other conductive matter, oil and other combustible matter from entering the controller.
- Do not drop or strike controller or servo motor. Isolate from all impact loads.
- Use the controller and servo motor under the following environmental conditions:

Environment		Conditions		
		Controller	Servo Motor	
Ambient temperature	[°C]	0 to +55 (non-freezing)	0 to +40 (non-freezing)	
	[°F]	32 to 131 (non-freezing)	32 to 104 (non-freezing)	
Ambient humidity		90%RH or less (non-condensing)	80%RH or less (non-condensing)	
Storage temperature	[°C]	-20 to +65 (non-freezing)	-15 to +70 (non-freezing)	
	[°F]	-4 to 149 (non-freezing)	5 to 158 (non-freezing)	
Storage humidity		90%RH or less (non-condensing)		
Ambience		Indoors (no direct sunlight) Free from corrosive gas, flammable gas, oil mist, dust and dirt		
Altitude		Max. 1000m (3280 ft) above sea level		
Vibration	[m/s <sup>2</sup> ]	5.9 (0.6G) or less	HC-MF Series HA-FF Series HC-UF 13 to 73	X · Y : 49.5 {5G}
			HC-SF81 HC-SF52 to 152 HC-SF53 to 153 HC-UF 72 · 152	X · Y : 24.5 {2.5G}
			HC-SF121 · 201 HC-SF202 · 352 HC-SF203 · 353 HC-UF202	X : 24.5 {2.5G} Y : 49 {5G}
			HC-SF301	X : 24.5 {2.5G} Y : 29.4 {3G}
	[ft/s <sup>2</sup> ]		HC-MF Series HA-FF Series HC-UF 13 to 73	X · Y : 64
			HC-SF81 HC-SF52 to 152 HC-SF53 to 153 HC-UF 72 · 152	X : 32 Y : 80
			HC-SF121 · 201 HC-SF202 · 352 HC-SF203 · 353 HC-UF202	X : 64 Y : 161
			HC-SF301	X : 38 Y : 96

## ⚠ CAUTION

- Securely attach the servo motor to the machine. If attach insecurely, the servo motor may come off during operation.
- The servo motor with reduction gear must be installed in the specified direction to prevent oil leakage.
- For safety of personnel, always cover rotating and moving parts.
- Never hit the servo motor or shaft, especially when coupling the servo motor to the machine. The encoder may become faulty.
- Do not subject the servo motor shaft to more than the permissible load. Otherwise, the shaft may break.
- When the equipment has been stored for an extended period of time, consult Mitsubishi.

### (2) Wiring

## ⚠ CAUTION

- Wire the equipment correctly and securely. Otherwise, the servo motor may misoperate..
- Do not install a power capacitor, surge absorber or radio noise filter (FR-BIF option) between the servo motor and controller.
- Connect the output terminals (U, V, W) correctly. Otherwise, the servo motor will operate improperly.
- Do not connect AC power directly to the servo motor. Otherwise, a fault may occur.
- The surge absorbing diode installed on the DC output signal relay must be wired in the specified direction. Otherwise, the emergency stop and other protective circuits may not operate.

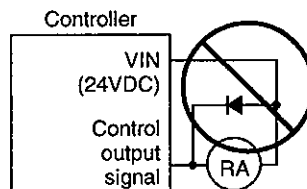

### (3) Test run adjustment

## ⚠ CAUTION

- Before operation, check the parameter settings. Improper settings may cause some machines to perform unexpected operation.
- The parameter settings must not be changed excessively. Operation will be insatiable.

#### (4) Usage

### ⚠ CAUTION

- Provide an external emergency stop circuit to ensure that operation can be stopped and power switched off immediately.
- Any person who is involved in disassembly and repair should be fully competent to do the work.
- The STOP key of the parameter unit is only valid for test run. Provide an emergency stop key independently of the STOP key.
- Before resetting an alarm, make sure that the run signal is off to prevent an accident. A sudden restart is made if an alarm is reset with the run signal on.
- Do not modify the equipment.
- Use a noise filter, etc. to minimize the influence of electromagnetic interference, which may be caused by electronic equipment used near the controller.
- Use the controller with the specified servo motor.
- The electromagnetic brake on the servo motor is designed to hold the motor shaft and should not be used for ordinary braking.
- For such reasons as service life and mechanical structure (e.g. where a ballscrew and the servo motor are coupled via a timing belt), the electromagnetic brake may not hold the motor shaft. To ensure safety, install a stopper on the machine side.

#### (5) Corrective actions

### ⚠ CAUTION

- When it is assumed that a hazardous condition may take place at the occur due to a power failure or a product fault, use a servo motor with electromagnetic brake or an external brake mechanism for the purpose of prevention.
- Configure the electromagnetic brake circuit so that it is activated not only by the controller signals but also by an external emergency stop signal.

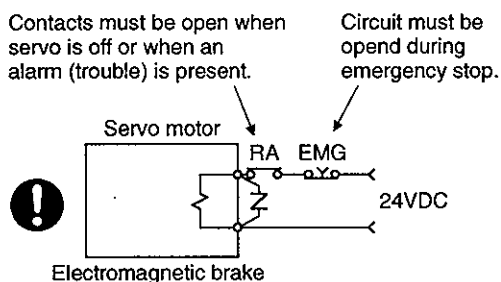

- When any alarm has occurred, eliminate its cause, ensure safety, and deactivate the alarm before restarting operation.
- When power is restored after an instantaneous power failure, keep away from the machine because the machine may be restarted suddenly (design the machine so that it is secured against hazard if restarted).

(6) Maintenance, inspection and parts replacement

 CAUTION

- With age, the electrolytic capacitor will deteriorate. To prevent a secondary accident due to a fault, it is recommended to replace the electrolytic capacitor every 10 years when used in general environment. Please consult our sales representative.

(7) Disposal

 CAUTION

- Dispose of the product as general industrial waste.

(8) General instruction

- To illustrate details, the equipment in the diagrams of this Instruction Manual may have been drawn without covers and safety guards. When the equipment is operated, the covers and safety guards must be installed as specified. Operation must be performed in accordance with this Instruction Manual.

## **COMPLIANCE WITH EC DIRECTIVES**

Use the controller and servo motor compliant with the EN Standard.

When EMC tests are run on a machine/device into which the servo amplifier has been installed, it must conform to the electromagnetic compatibility (immunity/emission) standards after it has satisfied the operating environment/electrical equipment specifications.

For the other EMC Directive guidelines on the servo amplifier, refer to the Chapter 9 and "EMC INSTALLATION GUIDELINES"(IB(NA)67303).

## **CONFORMANCE WITH UL/C-UL STANDARD**

Use the controller and servo motor compliant with the UL/C-UL Standard.

Also refer to Chapter 15 and take proper steps.



## CONTENTS

<b>1. FUNCTIONS AND CONFIGURATION</b>	<b>1- 1 to 1- 9</b>
1.1 Introduction	1- 1
1.1.1 Function block diagram	1- 1
1.1.2 Positioning system	1- 3
1.1.3 Roll feeding system	1- 4
1.2 Model Name Make-Up	1- 5
1.3 Combination with Servo Motor	1- 6
1.4 Parts Identification	1- 7
1.5 Controller and Its Auxiliary Equipment	1- 8
<b>2. INSTALLATION</b>	<b>2- 1 to 2- 3</b>
2.1 Environmental conditions	2- 1
2.2 Installation Direction and Clearances	2- 2
2.3 Keep out foreign materials	2- 2
2.4 Cable Stress	2- 3
<b>3. POSITIONING SYSTEM</b>	<b>3- 1 to 3-68</b>
3.1 Positioning System Specifications	3- 1
3.2 Standard Connection Examples	3- 2
3.2.1 Standard configuration (without the MR-H-D01 option card)	3- 3
3.2.2 Extension configuration 1 (with the MR-H-D01 option card)	3- 4
3.2.3 Extension configuration 2 (with the MR-H-D01 option card)	3- 6
3.2.4 Extension configuration 3 (with the MR-H-D01 option card)	3- 8
3.3 I/O Connectors	3-11
3.3.1 Connector signal layouts	3-11
3.3.2 Signal explanations	3-12
3.3.3 Control input/output signals	3-17
3.4 Operation	3-25
3.4.1 When Switching Power On for the First Time	3-25
3.4.2 Startup	3-26
3.4.3 Manual operation mode	3-30
3.4.4 Automatic operation mode	3-33
3.4.5 Manual zeroing mode	3-45
3.4.6 Automatic zeroing	3-53
3.5 Absolute position detection system	3-54
3.6 Point Table Data Setting Procedures	3-58
<b>4. ROLL FEEDING SYSTEM</b>	<b>4- 1 to 4-44</b>
4.1 Roll Feeding System Specifications	4- 1
4.2 Standard Connection Example	4- 2
4.2.1 Standard configuration (without the MR-H-D01 option card)	4- 3
4.2.2 Extension configuration 1 (with the MR-H-D01 option card)	4- 4
4.2.3 Extension configuration 2 (with the MR-H-D01 option card)	4- 6

4.3 I/O Connectors	4-9
4.3.1 Connector signal layouts	4-9
4.3.2 Signal explanations	4-10
4.3.3 Control input/output signals	4-14
4.4 Operation	4-22
4.4.1 When Switching Power On for the First Time	4-22
4.4.2 Startup	4-23
4.4.3 Manual operation remote mode	4-26
4.4.4 Manual Operation Mode	4-29
4.4.5 Automatic Operation Mode	4-30
4.5 Point Table Date Setting Procedures	4-38

<b>5. SIGNALS AND WIRINGS</b>	<b>5- 1 to 5-21</b>
-------------------------------	---------------------

5.1 Internal Connection Diagram of Servo Amplifier	5-2
5.2 Interfaces	5-3
5.2.1 Common line	5-3
5.2.2 Detailed description of the interfaces	5-4
5.3 Power Line Circuit	5-8
5.3.1 Connection example	5-8
5.3.2 Terminal	5-9
5.3.3 Power-on sequence	5-10
5.4 Connection of Controller and Servo Motor	5-11
5.4.1 Connection instructions	5-11
5.4.2 Connection diagram	5-11
5.4.3 Details of the servo motor side	5-13
5.4.4 Servo motor fan (HA-LH11K2 to HA-LH22K2)	5-17
5.5 Servo Motor with Electromagnetic Brake	5-17
5.5.1 Wiring instructions	5-17
5.5.2 Operation of electromagnetic brake	5-18
5.6 Grounding	5-20
5.7 Alarm Occurrence Timing Chart	5-21

<b>6. PARAMETERS</b>	<b>6- 1 to 6-25</b>
----------------------	---------------------

6.1 Parameter List	6-1
6.1.1 Parameter write inhibit	6-1
6.1.2 Lists	6-2
6.2 Detailed Explanation	6-21
6.2.1 Electronic gear	6-21
6.2.2 Changing the status display screen	6-22
6.2.3 Analog output	6-23
6.2.4 Changing the stopping pattern at the forward/reverse stroke end	6-24
6.2.5 Rough match output	6-24
6.2.6 Low acoustic noise mode	6-25

<b>7. PARAMETER UNIT AND DISPLAY SECTION</b>	<b>7- 1 to 7-18</b>
--	---------------------

7.1 Parameter Unit Keys	7-1
-------------------------	-----

7.2 Operation of the Parameter Unit	7- 2
7.3 Status Display	7-10
7.4 Alarm/Diagnosis	7-12
7.5 Servo Amplifier Display	7-14
7.5.1 Display examples	7-14
7.5.2 Selection of display data	7-15
7.6 Test Operation Mode	7-16
7.6.1 Jog operation	7-16
7.6.2 Positioning operation	7-17
7.6.3 1-step feed operation	7-18
7.6.4 Motorless operation	7-18
7.6.5 DO forced output	7-18

## 8. RS-232C COMMUNICATION FUNCTIONS

8-1 to 8-34

8.1 Configuration	8- 1
8.2 Communication Specifications	8- 2
8.3 Protocol	8- 2
8.4 Character Codes	8- 4
8.5 Error Codes	8- 4
8.6 Checksum	8- 5
8.7 Time-Out Operation	8- 5
8.8 Retry Operation	8- 5
8.9 Initialization	8- 6
8.10 Communication Procedure Example	8- 6
8.11 Command and Data No. List	8- 7
8.11.1 Read commands	8- 7
8.11.2 Write commands	8-12
8.12 Detailed Explanations of Commands	8-15
8.12.1 Data processing	8-15
8.12.2 Status display	8-17
8.12.3 Parameters	8-18
8.12.4 External I/O signal status (DIO diagnosis)	8-20
8.12.5 External output signal ON/OFF (DO forced output)	8-21
8.12.6 External input signal ON/OFF	8-22
8.12.7 Disable/enable of external I/O signals (DIO)	8-23
8.12.8 Test operation mode	8-24
8.12.9 Alarm history	8-27
8.12.10 Current alarm	8-28
8.12.11 Position block	8-30
8.12.12 Speed block	8-32
8.12.13 Selection between Japanese and English	8-34

## 9. COMPLIANCE WITH THE EUROPEAN EC DIRECTIVES AND UL/C-UL STANDARD

9- 1 to 9-24

9.1 Compliance With EC Directives	9- 1
9.1.1 What are EC directives?	9- 1
9.1.2 For compliance	9- 1
9.1.3 Standard connection examples	9- 5

9.2 Conformance With UL/C-UL Standard .....	9-19
9.2.1 Controller and servo motor used .....	9-19
9.2.2 Installation .....	9-19
9.2.3 Power supply .....	9-19
9.2.4 Wires .....	9-19
9.2.5 Crimping terminals and crimping tools .....	9-20
9.2.6 Fuses .....	9-20
9.2.7 Terminal block tightening torque .....	9-21
9.2.8 Standard connection example .....	9-21
9.3 Signals .....	9-22
9.3.1 Main circuit terminal block .....	9-22
9.3.2 Interfaces .....	9-23

<b>10. ADJUSTMENT</b>	<b>10- 1 to 10-10</b>
-----------------------	-----------------------

10.1 What Is Gain Adjustment? .....	10- 1
10.1.1 Difference between servo amplifier and other drives .....	10- 1
10.1.2 Basics of the servo system .....	10- 2
10.2 Gain adjustment .....	10- 3
10.2.1 Parameters required for gain adjustment .....	10- 3
10.2.2 Block diagram .....	10- 3
10.2.3 What is auto tuning? .....	10- 4
10.3 Gain Adjustment by Auto Tuning .....	10- 5
10.3.1 Adjustment method .....	10- 5
10.3.2 Valid conditions .....	10- 5
10.4 Manual Gain Adjustment .....	10- 6
10.4.1 When machine rigidity is low .....	10- 6
10.4.2 When the machine vibrates due to machine resonance frequency .....	10- 7
10.4.3 Load inertia moment is 20 or more times .....	10- 8
10.4.4 When shortening the settling time .....	10- 9
10.4.5 When the same gain is used for two or more axes .....	10-10

<b>11. INSPECTION</b>	<b>11- 1 to 11-2</b>
-----------------------	----------------------

11.1 Inspection .....	11- 1
11.2 Life .....	11- 1

<b>12. TROUBLESHOOTING</b>	<b>12-1 to 12-11</b>
----------------------------	----------------------

12.1 Trouble at Start-Up .....	12- 1
12.2 When Alarm or Warning Has Occurred .....	12- 2
12.2.1 Alarms and Warning list .....	12- 2
12.2.2 Remedies for alarms .....	12- 3
12.2.3 Remedies for warnings .....	12- 9
12.2.4 RS-232C communication error .....	12-10
12.3 Clearing the Alarm History .....	12-11

<b>13. SPECIFICATIONS</b>	<b>13- 1 to 13- 9</b>
---------------------------	-----------------------

13.1 Standard specifications .....	13- 1
13.2 Outline Dimensional Drawings .....	13- 2
13.2.1 Controllers .....	13- 2
13.2.2 Connectors .....	13- 7

<b>14. CHARACTERISTICS</b>	<b>14- 1 to 14- 8</b>
----------------------------	-----------------------

14.1 Overload Protection Characteristics .....	14- 1
14.2 Power Supply Equipment Capacity and Generated Loss .....	14- 3
14.3 Dynamic Brake Characteristics .....	14- 5
14.4 Encoder Cable Flexing Life .....	14- 8

<b>15. OPTIONS AND AUXILIARY EQUIPMENT</b>	<b>15- 1 to 15- 56</b>
--	------------------------

15.1 Options .....	15- 1
15.1.1 Parameter unit .....	15- 1
15.1.2 Regenerative brake options .....	15- 3
15.1.3 Brake unit .....	15- 11
15.1.4 Power return converter .....	15- 14
15.1.5 External dynamic brake .....	15- 16
15.1.6 Cables and connectors .....	15- 19
15.1.7 Junction terminal block (MR-TB50) .....	15- 29
15.1.8 Servo Configuration Software .....	15- 31
15.1.9 Heat sink outside mounting attachment (MR-ACN) .....	15- 32
15.1.10 Large setting/display unit (MR-PRU02) .....	15- 34
15.1.11 External Digital display (MR-DP60) .....	15- 36
15.1.12 Manual Pulse Generator (MR-HDP01) .....	15- 38
15.1.13 Battery (MR-BAT, A6BAT) .....	15- 39
15.1.14 6-Digit Digital Switch (MR-DS60) .....	15- 40
15.1.15 MR-H-D01 option card .....	15- 42
15.1.16 Battery (MR-BAT, A6BAT) .....	15- 43
15.2 Auxiliary Equipment .....	15- 44
15.2.1 Recommended wires .....	15- 44
15.2.2 No-fuse breakers, magnetic contactors .....	15- 46
15.2.3 Power factor improving reactors .....	15- 47
15.2.4 Relays .....	15- 47
15.2.5 Surge absorbers .....	15- 48
15.2.6 Noise reduction techniques .....	15- 49
15.2.7 Leakage current breaker .....	15- 54
15.2.8 Setting potentiometers for analog inputs .....	15- 56

<b>Appendix</b>	<b>App- 1 to App- 3</b>
-----------------	-------------------------

POINT TABLE DATA RECORDING FORMS .....	App- 1
--	--------

# Optional Servo Motor Instruction Manual CONTENTS

The rough table of contents of the optional MELSERVO Servo Motor Instruction Manual is introduced here for your reference. Note that the contents of the Servo Motor Instruction Manual are not included in the Controller Instruction Manual.

1. INTRODUCTION

2. INSTALLATION

3. CONNECTORS USED FOR SERVO MOTOR WIRING

4. INSPECTION

5. SPECIFICATIONS

6. CHARACTERISTICS

7. OUTLINE DIMENSION DRAWINGS

### About the Manuals

This Instruction Manual and the MELSERVO Servo Motor Instruction Manual are required if you use the Single-axis amplifier built-in controller MR-H-ACN for the first time. Always purchase them and use the MR-H-ACN safely.

#### Relevant manuals

Manual Name	Manual No.
MELSERVO-H Series TO USE THE AC SERVO SAFETY	IB(NA)67367
MELSERVO Servo Motor Instruction Manual	SH(NA)3181
EMC Installation Guidelines	IB(NA)67310

# 1. FUNCTIONS AND CONFIGURATION

---

## 1. FUNCTIONS AND CONFIGURATION

### 1.1 Introduction

The MR-H-ACN single-axis amplifier built-in controller is the MR-H-AN general-purpose AC servo amplifier having a single-axis positioning function. The function performs high-duty, repetitive positioning operation by merely setting the position data (target position), motor speed, acceleration and deceleration time constants, etc. in the point tables (position blocks, speed blocks) as if you were setting the parameter values. It is optimum when you wish to make up a simple positioning system without programs or to simplify the system.

A servo motor equipped with absolute position encoder is available. By simply adding a battery to the controller, you can configure up an absolute position detection system, making zeroing unnecessary at power-on, alarm occurrence or the like.

#### 1.1.1 Function block diagram

The function block diagram of the MR-H-ACN is shown on the next page.



# 1. FUNCTIONS AND CONFIGURATION

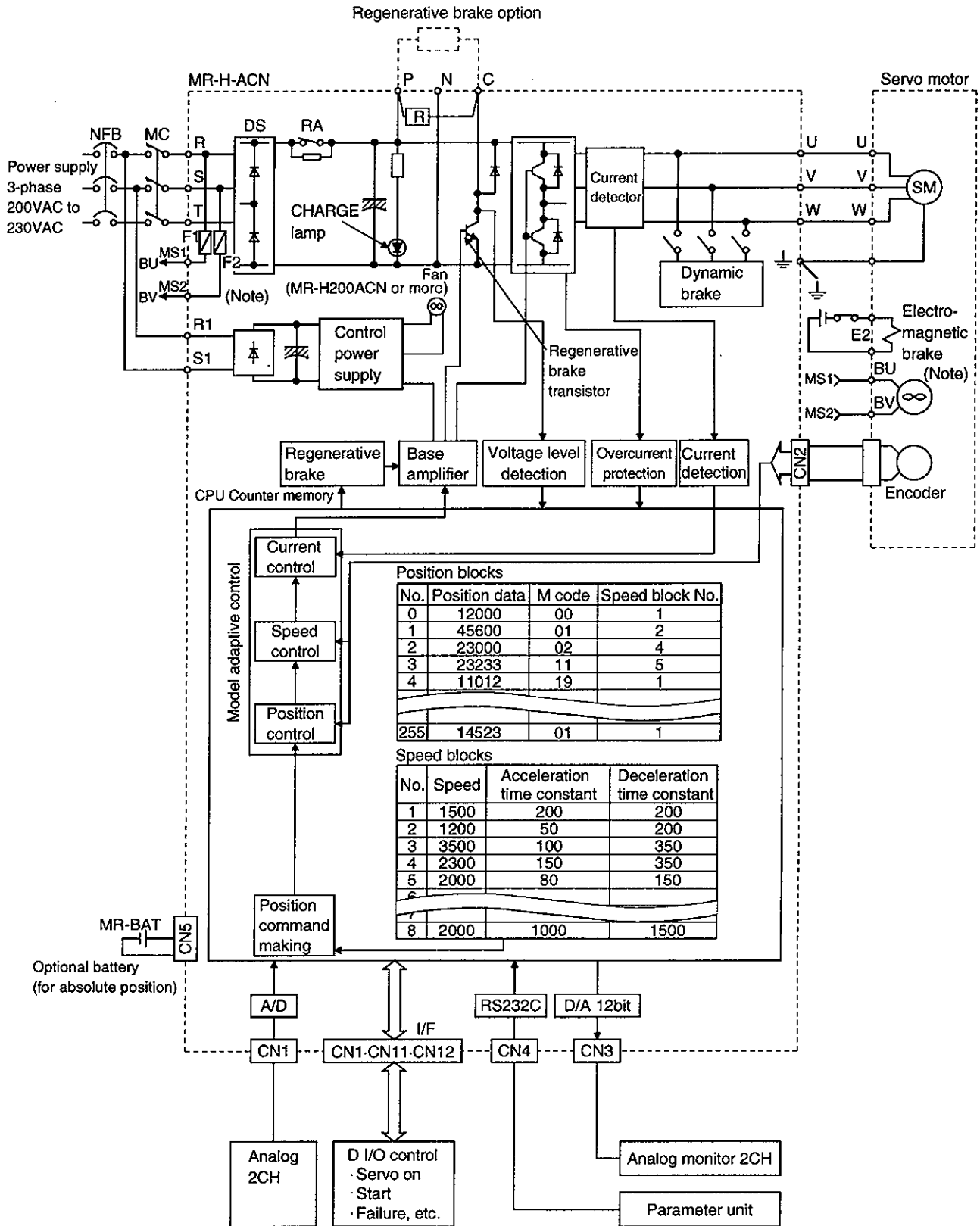

Note: For 11kW or more.

# 1. FUNCTIONS AND CONFIGURATION

## 1.1.2 Positioning system

### (1) Main functions

- (a) Positioning for up to 256 positions using point table numbers. (8 positions as standard, 256 positions when the option card is used)
- (b) By using the MR-H-D01 option card, the speed is set externally as desired from among eight speeds.
- (c) Easily compatible with an absolute position system.
- (d) Position data can also be specified externally in six BCD digits. (MR-H-D01 option card used)
- (e) Four zeroing methods

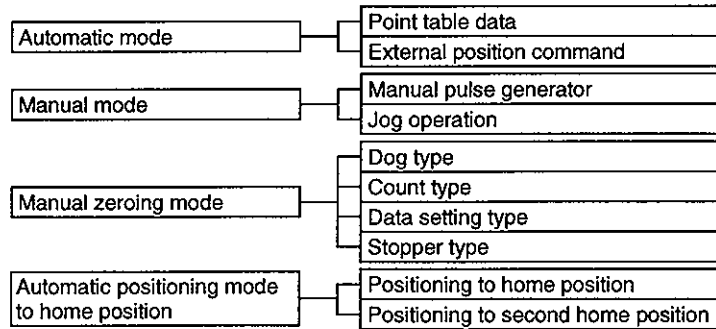

### (2) Configuration example

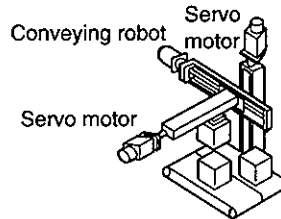

Point table

Position Block

Position Block No.	Position Data	M Code	Speed Block No.
0	120000	00	1
1	485690	11	3
2	120000	19	8
3	986723	55	2
⋮	⋮	⋮	⋮
7(255)	120000	01	1

Speed Block

Speed Block No.	Speed	Acceleration Time	Deceleration Time
1	500.0	220	220
2	1200.0	46	50
3	1750.0	65	80
4	1892.0	66	76
5	48.3	23	23
6	3000.0	72	72
7	123.4	125	298
8	2396.9	99	333

# 1. FUNCTIONS AND CONFIGURATION

## 1.1.3 Roll feeding system

### (1) Main functions

- (a) Two different feed distances can be set externally as desired.
- (b) Speeds can be specified externally as desired from among two speeds as standard or from among eight speeds when the option card is used.
- (c) The feed distance can also be specified externally in six BCD digits. (MR-H-D01 option card used)

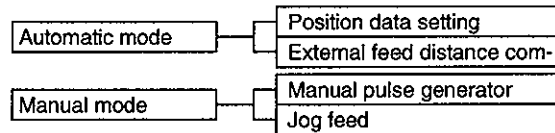

### (2) Configuration example

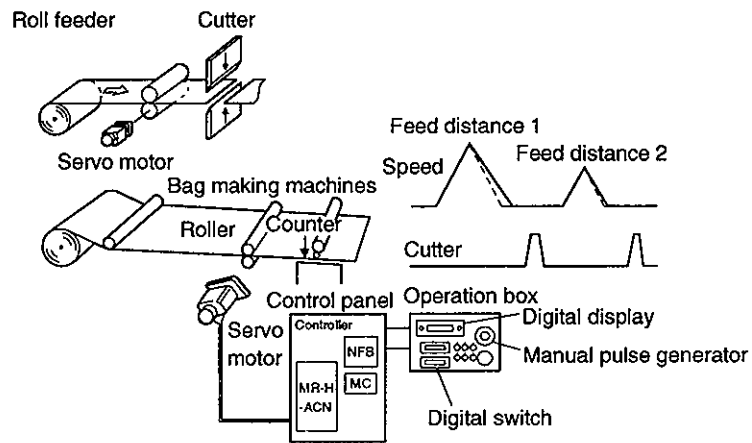

# 1. FUNCTIONS AND CONFIGURATION

## 1.2 Model Name Make-Up

### (1) Name plate

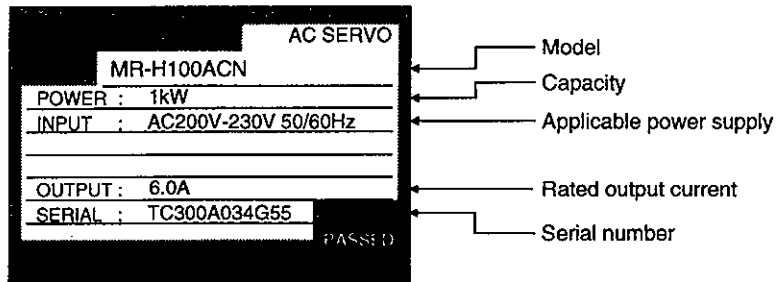

### (2) Model

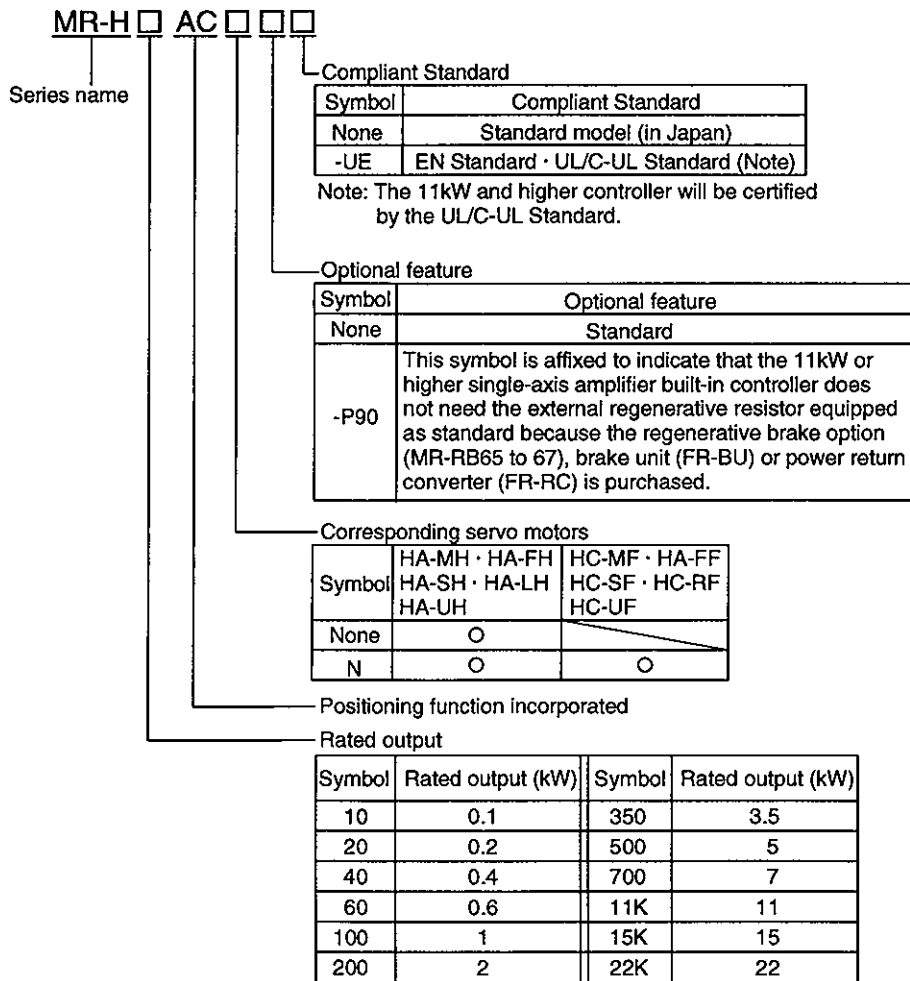

# 1. FUNCTIONS AND CONFIGURATION

## 1.3 Combination with Servo Motor

The following table lists combinations of controller and servo motors. The same combinations apply to the models with electromagnetic brakes, the models with reduction gears, the EN Standard-compliant models and the UL/C-UL Standard-compliant models. For combination with the HA-MH, HA-FH, HA-SH and HA-UH series servo motors, refer to parameter No. 1 in Section 6.1.2 (2).

Controller	Servo Motor								
	HC-MF□	HA-FF□	(Note 2) HC-SF□			HC-RF□	(Note 1) HC-UF□		HA-LH□
			1000r/min	2000r/min	3000r/min		2000r/min	3000r/min	
MR-H10ACN		053 · 13						13	
MR-H20ACN	053 · 13	23							
MR-H40ACN	23	33 · 43						23	
MR-H60ACN	43	63		52	53			43	52
MR-H100ACN	73		81	102	103		72	73	
MR-H200ACN			121 · 201	152 · 202	153 · 203	103 · 153	152		102 · 152
MR-H350ACN			301	352	353	203	202		202
MR-H500ACN				502		353 · 503	352 · 502		302 · 502
MR-H700ACN				702					702
MR-H11KACN									11K2
MR-H15KACN									15K2
MR-H22KACN									22K2

Note 1: The HC-UF73·HC-SF203·HC-SF353 may not be connected depending on the production timing of the servo amplifier. Please contact us.

# 1. FUNCTIONS AND CONFIGURATION

## 1.4 Parts Identification

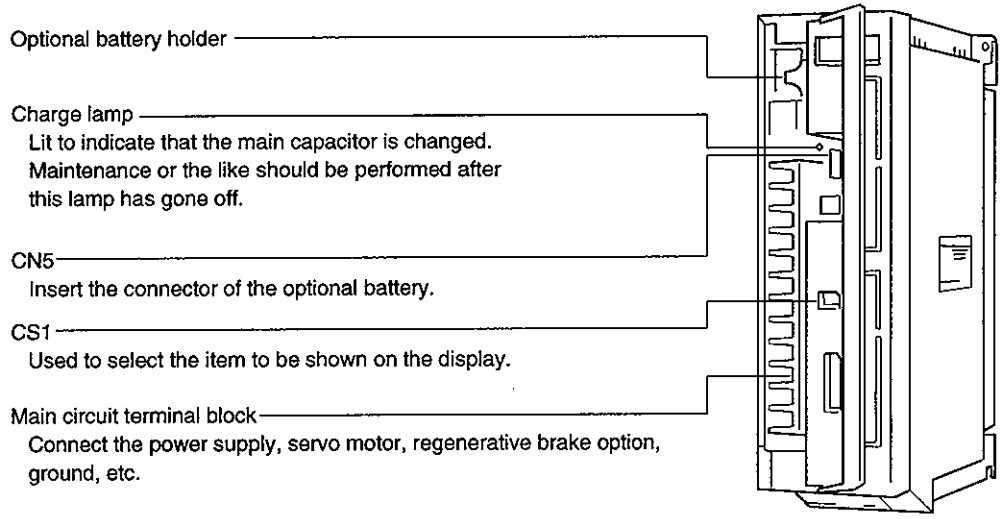
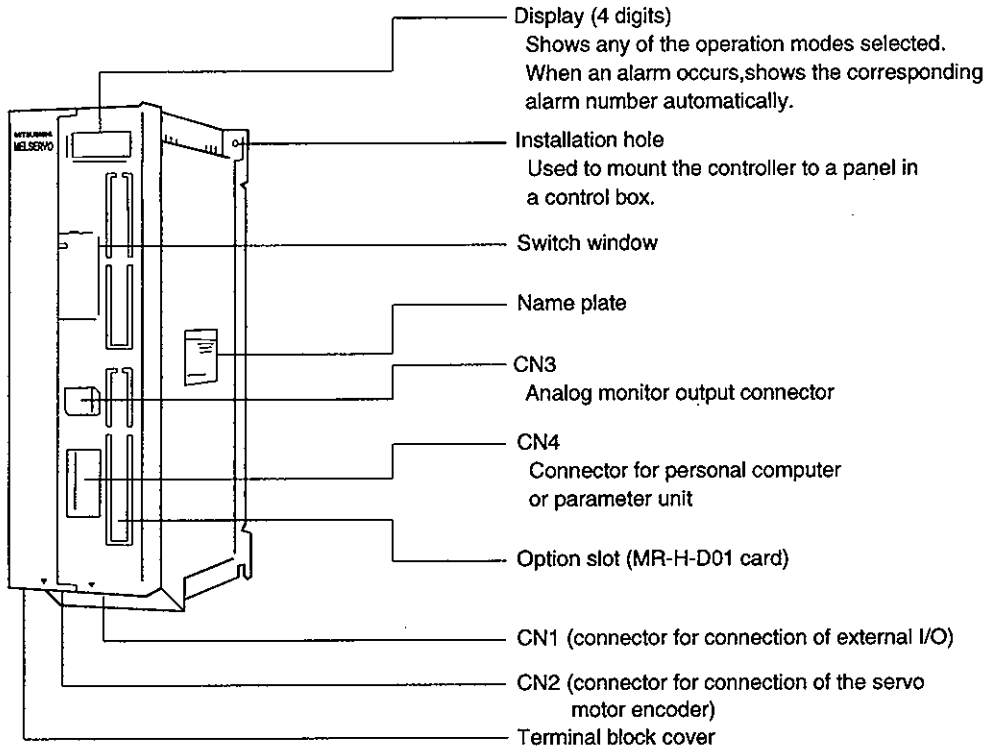

# 1. FUNCTIONS AND CONFIGURATION

## 1.5 Controller and Its Auxiliary Equipment

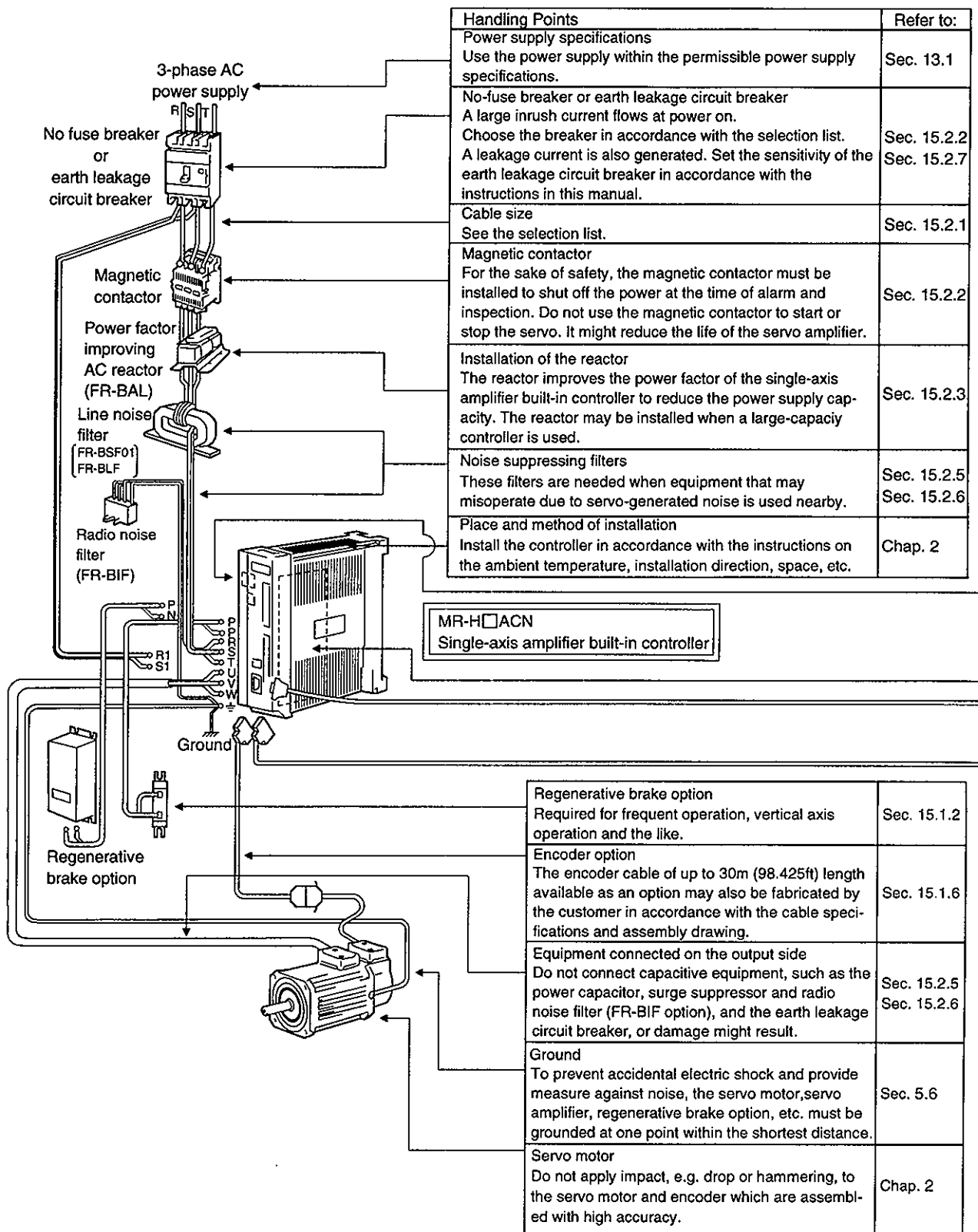

# 1. FUNCTIONS AND CONFIGURATION

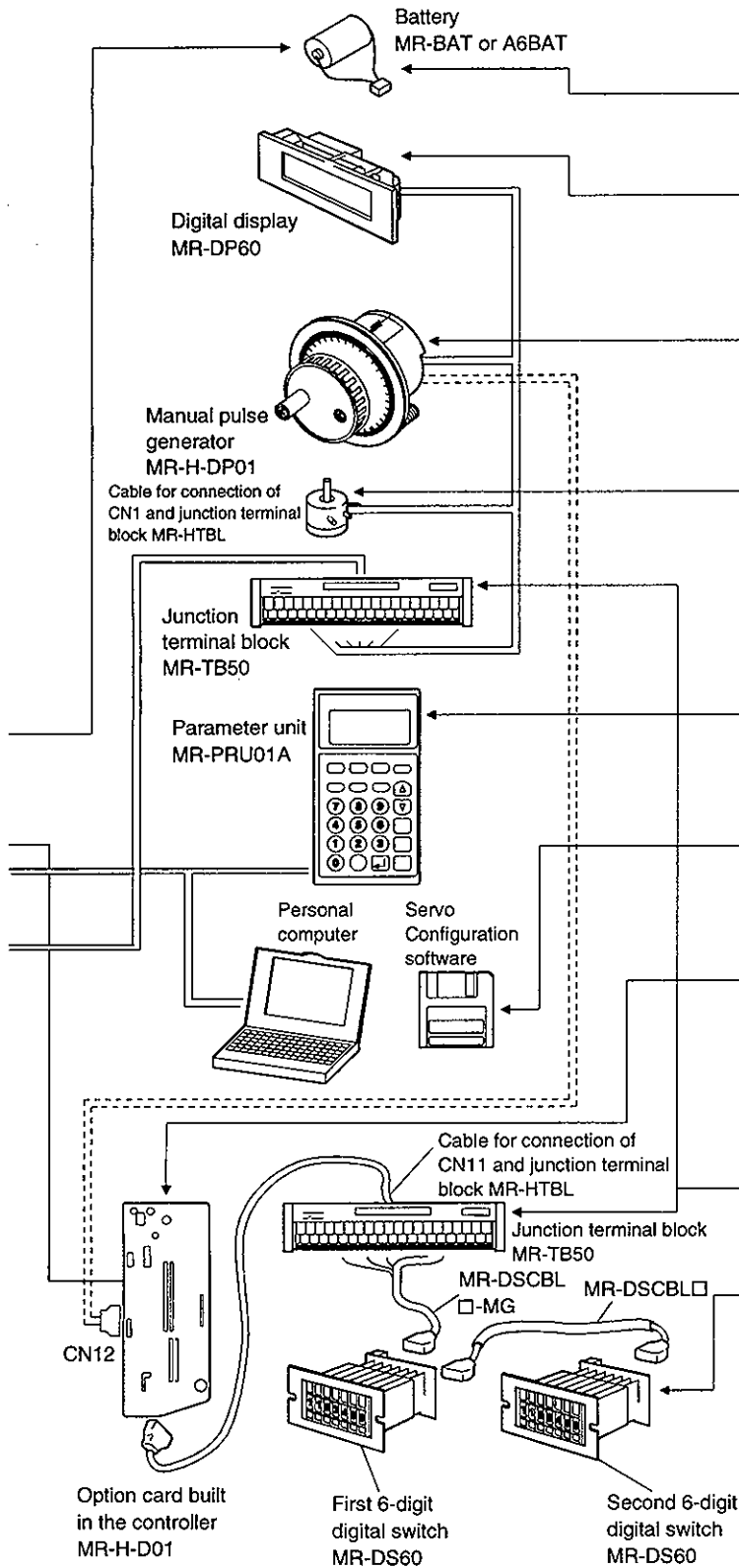

Handling Points	Refer to:
<b>Battery</b> By only fitting the battery to the controller used with a servo motor provided with an absolute position encoder, positioning can be performed easily.	Sec. 3.5
<b>Digital display</b> · The signed 6-digit display uses seven-segment LEDs to provide clear display information to remote locations. · Any of 14 different display data, such as the current position(absolute position) and machine deceleration can be selected according to applications.	Sec.15.1.11
<b>Manual pulse generator</b> · The manual pulse generator enables the manual feeding of a shifter, rotary table, etc. · Any of three different command pulse magnification, ×1, ×10, and ×100, can be selected by parameter setting.	Sec.15.1.12
<b>Volume</b> · The specified feedrate can be limited at the rate of 0 through 200%. · The specified torque can be limited at the rate of 0 through 100%.	Sec. 15.2.8
<b>Parameter unit</b> · The liquid crystal screen of 13 characters wide by 4 lines long and the 35 keys allow position data to be edited, operation to be taught, various parameters to be set, the operating status such as the current position and machine speed to be monitored, an alarm to be diagnosed, the display language to be selected between Japanese and English, test run to be performed, parameters to be copied	Chap. 7 Sec. 15.1.1
<b>Personal computer, Servo Configuration software</b> Using the Servo Configuration software allows parameter setting, status display monitoring, etc. to be made on a personal computer.	Chap. 8 Sec. 15.1.8
<b>Option card</b> · Addition of the MR-H-D01 option card provides extra I/O signals. · Extra I/O signals(CN11) can be provided to match functions, such as the positioning system and roll feeding system. · Extra pulse train inputs(CN12) allow the manual pulse generator to be connected and 5V power to be supplied.	Sec. 15.1.15
<b>Junction terminal block</b> · Makes soldering in the external connector unnecessary.	Sec.14.1.7
The signed 6-digit digital switch allows: · Position data to be specified; and · Feed distance to be set. (MR-H-D01 is required)	Sec.15.1.14



## 2. INSTALLATION

### 2. INSTALLATION



#### CAUTION

- Stacking in excess of the limited number of products is not allowed.
- Install the equipment to incombustibles. Installing them directly or close to combustibles will led to a fire.
- Install the equipment in a load-bearing place in accordance with this Instruction Manual.
- Do not get on or put heavy load on the equipment to prevent injury.
- Use the equipment within the specified environmental condition range.
- Provide an adequate protection to prevent screws, metallic detritus and other conductive matter or oil and other combustible matter from entering the controller.
- Do not block the intake/exhaust ports of the controller. Otherwise, a fault may occur.
- Do not subject the controller to drop impact or shock loads as they are precision equipment.
- Do not install or operate a faulty controller.
- When the product has been stored for an extended period of time, consult Mitsubishi.

#### 2.1 Environmental conditions

Environment	Conditions
Ambient temperature	0 to +55 [°C] (non-freezing)
	32 to +131 [°F] (non-freezing)
Ambient humidity	90%RH or less (non-condensing)
Storage temperature	-20 to +65 [°C] (non-freezing)
	-4 to +149 [°F] (non-freezing)
Storage humidity	90%RH or less (non-condensing)
Ambient	Indoors (no direct sunlight) Free from corrosive gas, flammable gas, oil mist, dust and dirt
Altitude	Max. 1000m (3280 ft) above sea level
Vibration	5.9 [m/s <sup>2</sup> ] {0.6G} or less
	19.4 [ft/s <sup>2</sup> ] or less

## 2. INSTALLATION

### 2.2 Installation Direction and Clearances



#### CAUTION

- Do not hold the front cover to transport the controller. The controller may drop.
- The equipment must be installed in the specified direction. Otherwise, a fault may occur.
- Leave specified clearances between the controller and control box inside walls or other equipment.

#### (1) Installation of one controller

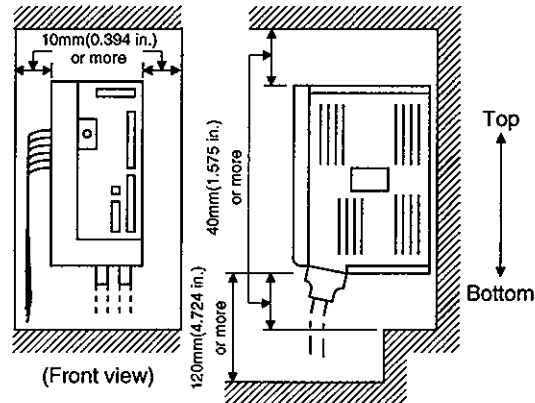

#### (2) Installation of two or more controllers

Leave a large clearance between the top of the controller and the internal surface of the control box, and install a fan to prevent the internal temperature of the control box from exceeding the environmental conditions.

Reserve an at least 10mm (0.394 in.) clearance between the controllers. For the MR-H10ACN to MR-H60ACN, reserve an at least 15mm (0.591 in.) clearance as a wiring space.

#### (3) Others

When using heat generating equipment such as the regenerative brake option, install them with full consideration of heat generation so that the controller is not affected.

Install the controller on a perpendicular wall in the correct vertical direction.

### 2.3 Keep out foreign materials

- (1) When installing the unit in a control box, prevent drill chips and wire fragments from entering the controller.
- (2) Prevent oil, water, metallic dust, etc. from entering the controller through openings in the control box or a fan installed on the ceiling.
- (3) When installing the control box in a place where there are toxic gas, dirt and dust, provide positive pressure in the control box by forcing in clean air to prevent such materials from entering the control box.

## 2. INSTALLATION

---

### 2.4 Cable Stress

- (1) The way of clamping the cable must be fully examined so that flexing stress and cable's own weight stress are not applied to the cable connection.
- (2) In any application where the servo motor moves, the cables should be free from excessive stress. When the servo motor moves, e.g. the encoder cable and servo motor wiring are contained in a cable bearer, run the cables so that their flexing portions fall within the flex life range of the encoder cable. Fix the encoder cable and power cable of the servo motor.
- (3) Avoid any probability that the cable sheath might be cut by sharp chips, rubbed by a machine corner or stamped by workers or vehicles.
- (4) For installation on a machine where the servo motor will move, the flexing radius should be made as large as possible. Refer to section 12.4 for the flexing life.

### 3. POSITIONING SYSTEM

#### 3 POSITIONING SYSTEM

##### 3.1 Positioning System Specifications

Item		Specifications	
Command system	Point table number input	Operational specifications	Position block number is specified for positioning.
		Position command input	<ul style="list-style-type: none"> <li>The contact input allows positions to be selected from those in 8 position blocks as standard or from those in 256 position blocks when the option card (MR-H-D01) is used.</li> <li>Feed length setting range for 1 position: <math>\pm 1\mu\text{m}</math> to <math>\pm 999.999\text{m}</math></li> </ul>
		Speed command input	Speeds and acceleration/deceleration times are selected from those in 8 speed blocks.
		System	Absolute command (signed)/incremental command
	Position data input Option card (MR-H-D01) used	Operational specifications	Digital switch or contact data input is used for positioning.
		Position command input	<ul style="list-style-type: none"> <li>Signed 6-digit BCD digital switch (MR-SD60) or contact input</li> <li>Feed length input setting range: <math>\pm 1\mu\text{m}</math> to <math>\pm 999.999\text{m}</math></li> </ul>
		Speed command input	Using the contact input, speed and acceleration/deceleration time are selected from those in 8 speed blocks.
		System	Absolute command (signed)/incremental command
Operation mode	Automatic mode		Positioning operation is performed once under the speed/position commands
	Manual mode	Jog	Jog operation is performed by the parameter unit or contact input under the speed command.
		Manual pulse generator (MR-HDP01)	Manual pulse generator (MR-HDP01) is used for manual feed. <ul style="list-style-type: none"> <li>Input pulse specifications: 2-phase pulse train with <math>90^\circ</math> phase difference (A phase, B phase) <math>\cdots \cdots</math> multiplied by 4</li> <li>Input pulse form: open collector input</li> <li>Max. input pulse frequency: open collector input 200kpps</li> <li>Command pulse magnification: any of <math>\times 1</math>, <math>\times 10</math> and <math>\times 100</math> is selected using the internal parameter. The option card (MR-H-D01) may be used to select the above externally.</li> </ul>
	(Note) Manual zeroing mode	Dog type	Marking pulse given past the proximity dog is used for zeroing. <ul style="list-style-type: none"> <li>Zero address can be set.</li> <li>Zero shift can be performed.</li> <li>Zeroing direction can be selected.</li> <li>Zeroing can be started automatically after a return from the limit.</li> <li>Zeroing can be started automatically after a return from the dog.</li> </ul>
		Count type	Detector pulses counted after contact with the proximity dog are used for zeroing. <ul style="list-style-type: none"> <li>Zero address can be set.</li> <li>Zero shift can be performed.</li> <li>Zeroing direction can be selected.</li> <li>Zeroing can be started automatically after a return from the limit.</li> <li>Zeroing can be started automatically after a return from the dog.</li> </ul>
		Data setting type	Dog is not used for zeroing. <ul style="list-style-type: none"> <li>Any position can be set as a home position by manual operation, etc.</li> <li>Zero address can be set.</li> </ul>
		Stopper type	Dog is not used for zeroing. <ul style="list-style-type: none"> <li>Stop position can be set as a mechanical home position.</li> <li>Zero address can be set.</li> </ul>
	Automatic positioning to home position		<ul style="list-style-type: none"> <li>High-speed automatic return to a defined home position.</li> <li>A second home position can be set.</li> </ul>

Note: Similar function is also available for home position setting in absolute position detection system.

### 3. POSITIONING SYSTEM

Item	Specifications
Functions of positioning control	<ul style="list-style-type: none"> <li>• Absolute position detection</li> <li>• Teaching function: Teaching can be performed by the parameter unit.</li> <li>• M code output: 0 to 3 as standard, 0 to 99 when the option card (MR-H-D01) is used</li> <li>• Acceleration/deceleration method setting (S-shaped acceleration/deceleration, separate settings for acceleration and deceleration)</li> <li>• Backlash compensation</li> <li>• Alarm code is output using the option card (MR-H-D01)</li> <li>• Prevention of overtravel by the external limit switch</li> </ul>

#### 3.2 Standard Connection Examples



**WARNING**

- Any person who is involved in wiring should be fully competent to do the work.
- Before starting wiring, make sure that the charge lamp is off more than 10 minutes after power-off, and then confirm that the voltage across terminals P-N is safe with a tester or similar device. Otherwise, you may get an electric shock.
- Do not attempt to wire the controller and servo motor until they have been installed. Otherwise, you may get an electric shock.
- The cables should not be damaged, stressed excessively, loaded heavily, or pinched. Otherwise, you may get an electric shock.



**CAUTION**

- Wire the equipment correctly and securely. Otherwise, the servo motor may misoperate, resulting in injury.
- Connect cables to correct terminals to prevent a burst, fault, etc.
- Ensure that polarity (+, -) is correct. Otherwise, a burst, fault, etc. may occur.
- The surge absorbing diode installed to the DC relay designed for control output should be fitted in the specified direction. Otherwise, the signal is not output due to a fault, disabling the emergency stop and other protective circuits.

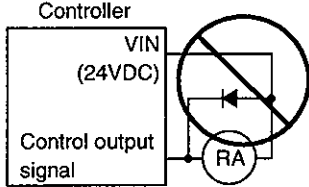

- Use a noise filter, etc. to minimize the influence of electromagnetic interference, which may be given to electronic equipment used near the controller.
- Do not install a power capacitor, surge suppressor or radio noise filter (FR-BIF option) with the power line of the controller.
- When using the regenerative brake resistor, switch power off with the alarm signal. Otherwise, a transistor fault or the like may overheat the regenerative brake resistor, causing a fire.
- Do not modify the equipment.

### 3. POSITIONING SYSTEM

#### 3.2.1 Standard configuration (without the MR-H-D01 option card)

Positioning operation according to 8-position point table

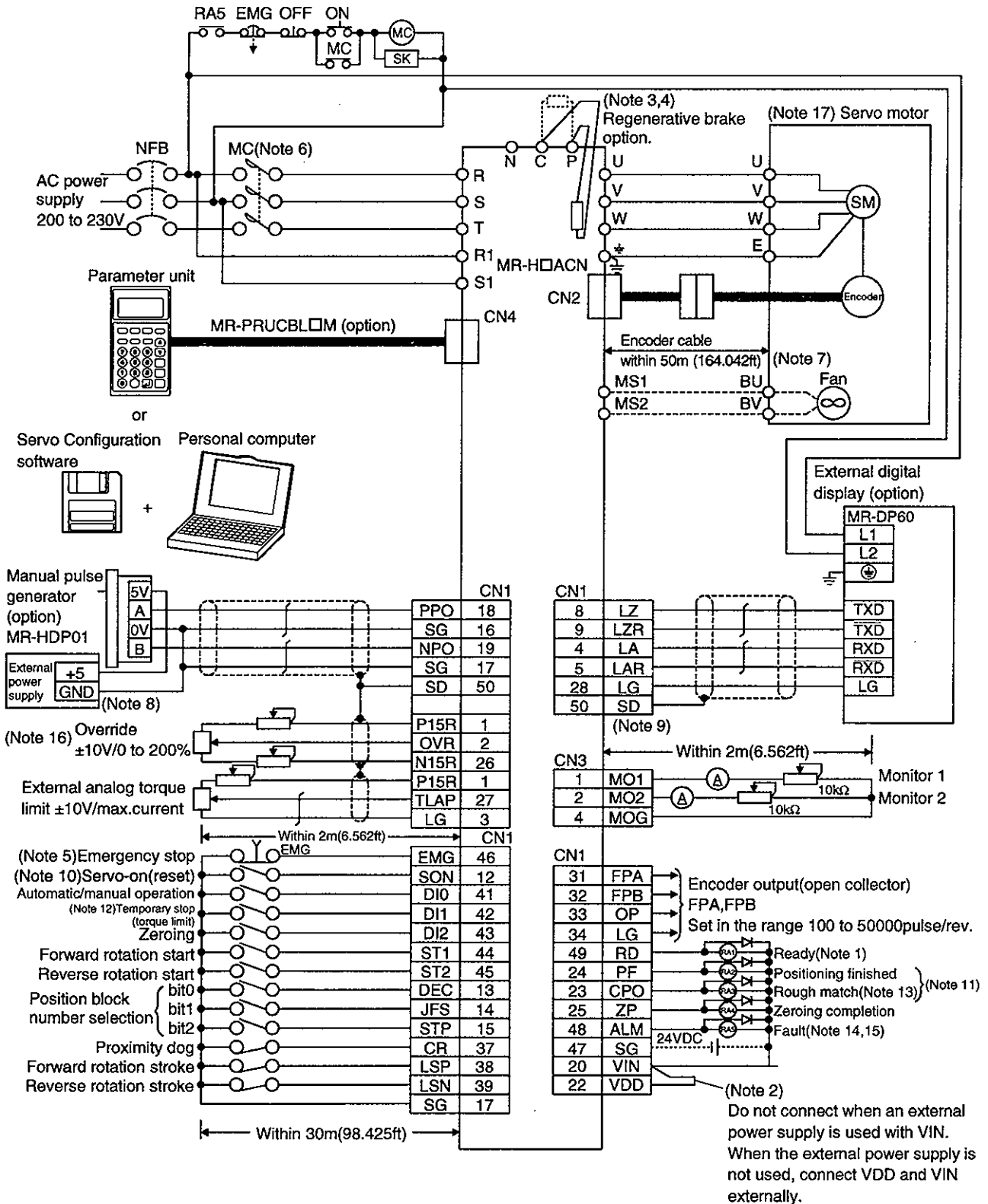

For notes, refer to page 3-10.

### 3. POSITIONING SYSTEM

#### 3.2.2 Extension configuration 1 (with the MR-H-D01 option card)

Positioning operation according to 256-position point table  
Set 1□□3 in parameter No.65.

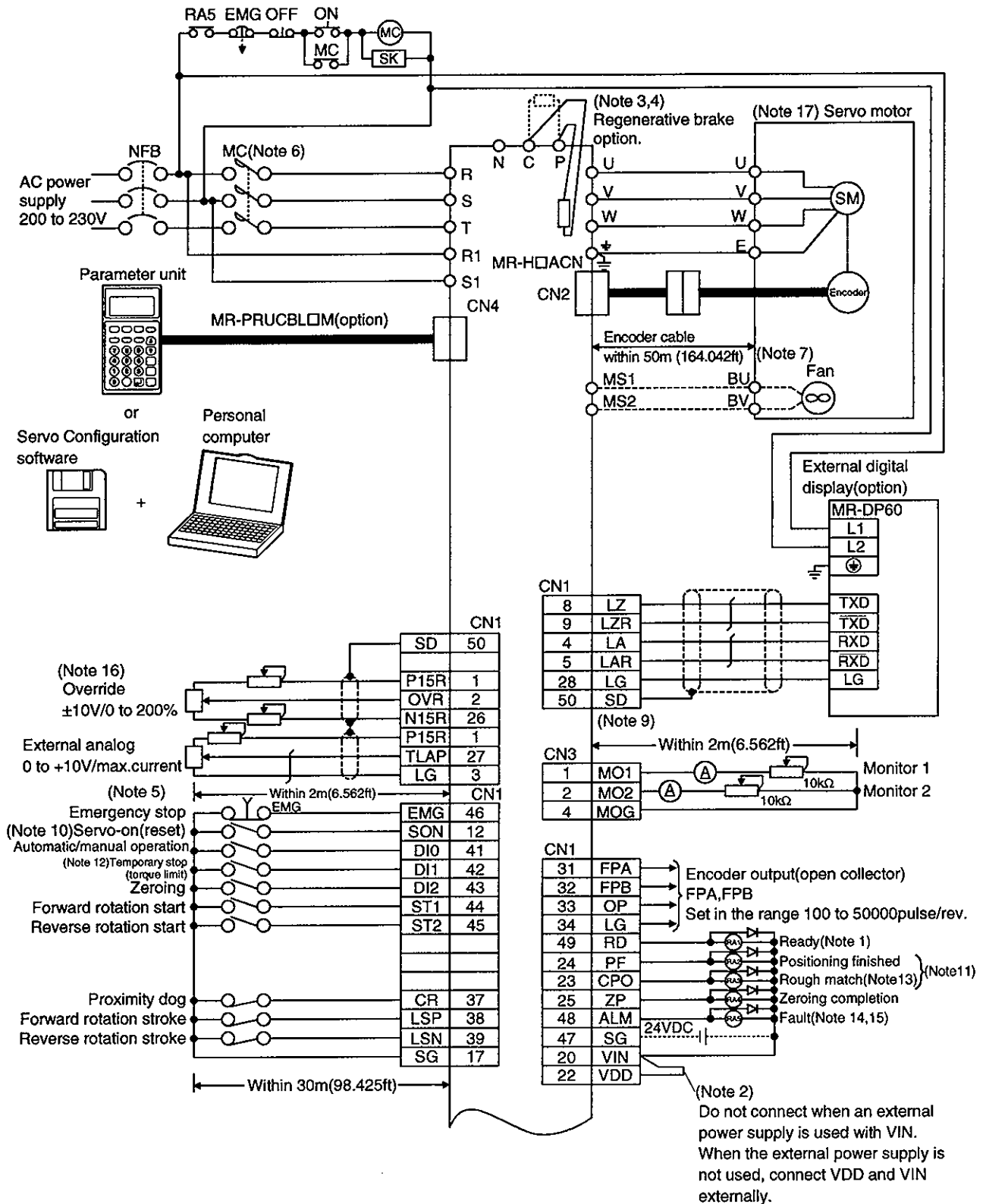
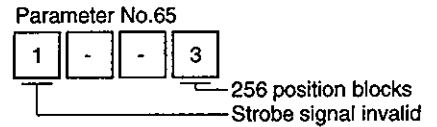

### 3. POSITIONING SYSTEM

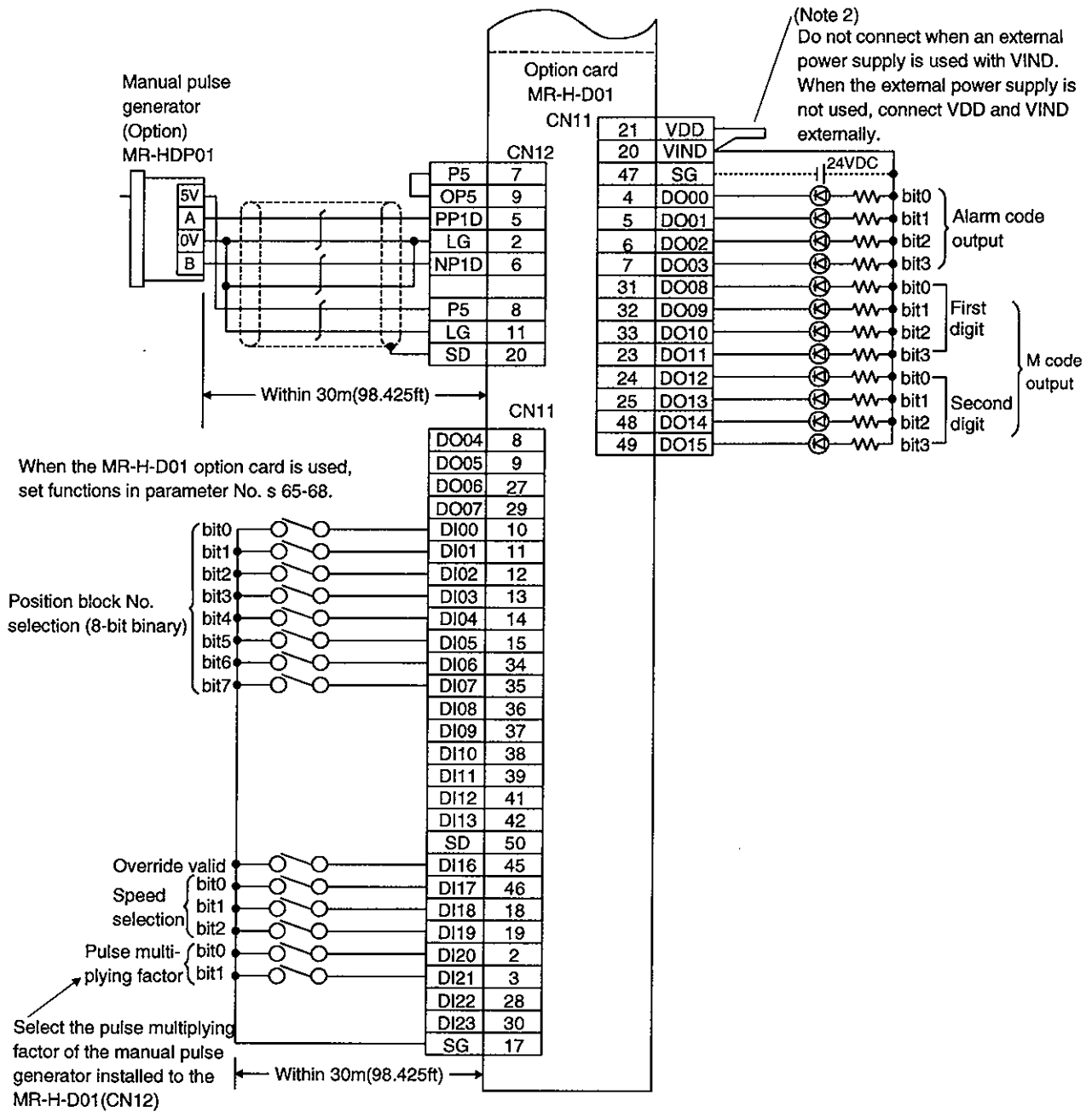

For notes, refer to page 3-10.



### 3. POSITIONING SYSTEM

#### 3.2.3 Extension configuration 2 (with the MR-H-D01 option card)

Positioning operation under digital switch (MR-DS60) position data command

The digital switch used must be optional MR-DS60.

Set 1□□1 in parameter No.65.

Parameter No.65



BCD3 digits×2 input  
Digital switch is used  
Strobe signal invalid

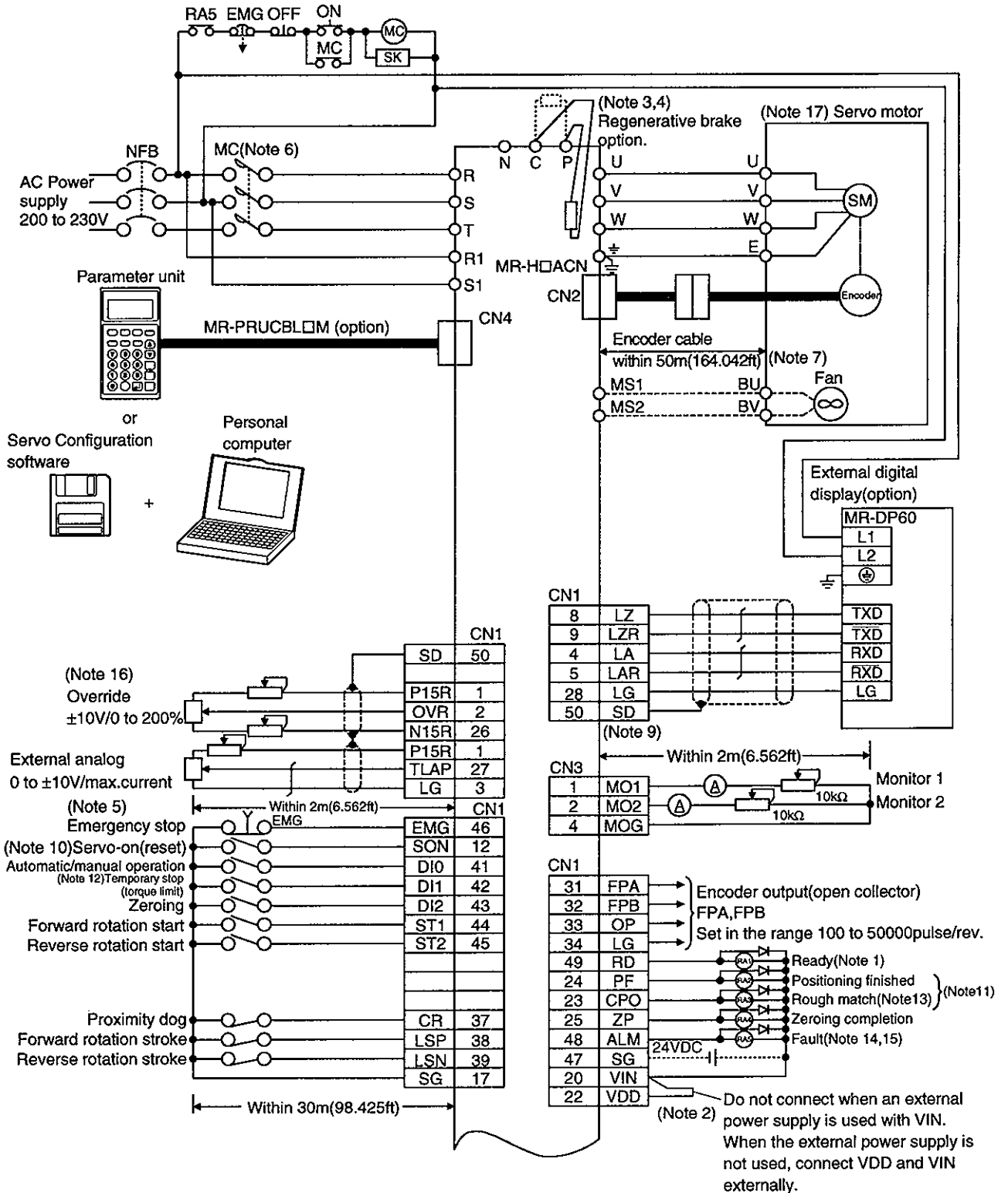

### 3. POSITIONING SYSTEM

When using the MR-H-D01 option card, set functions in parameters No. 65 to 68.

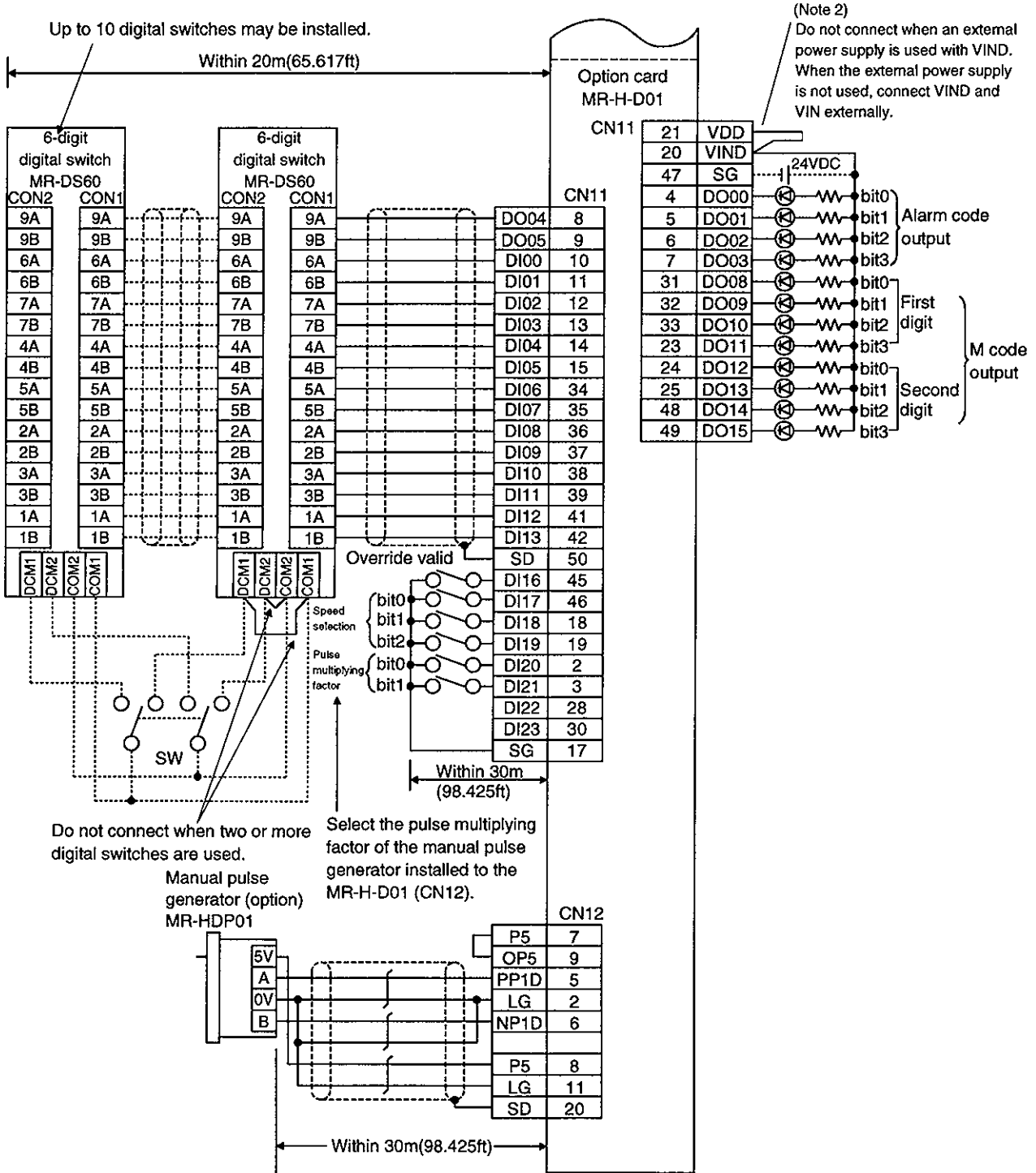

For notes, refer to page 3-10.

### 3. POSITIONING SYSTEM

#### 3.2.4 Extension configuration 3 (with the MR-H-D01 option card)

Positioning operation under programmable controller position data command

The wiring example shown in this section assumes that Mitsubishi's A1S series programmable controller are used.

When the programmable control are used, set 0□□1 in parameter No.65.

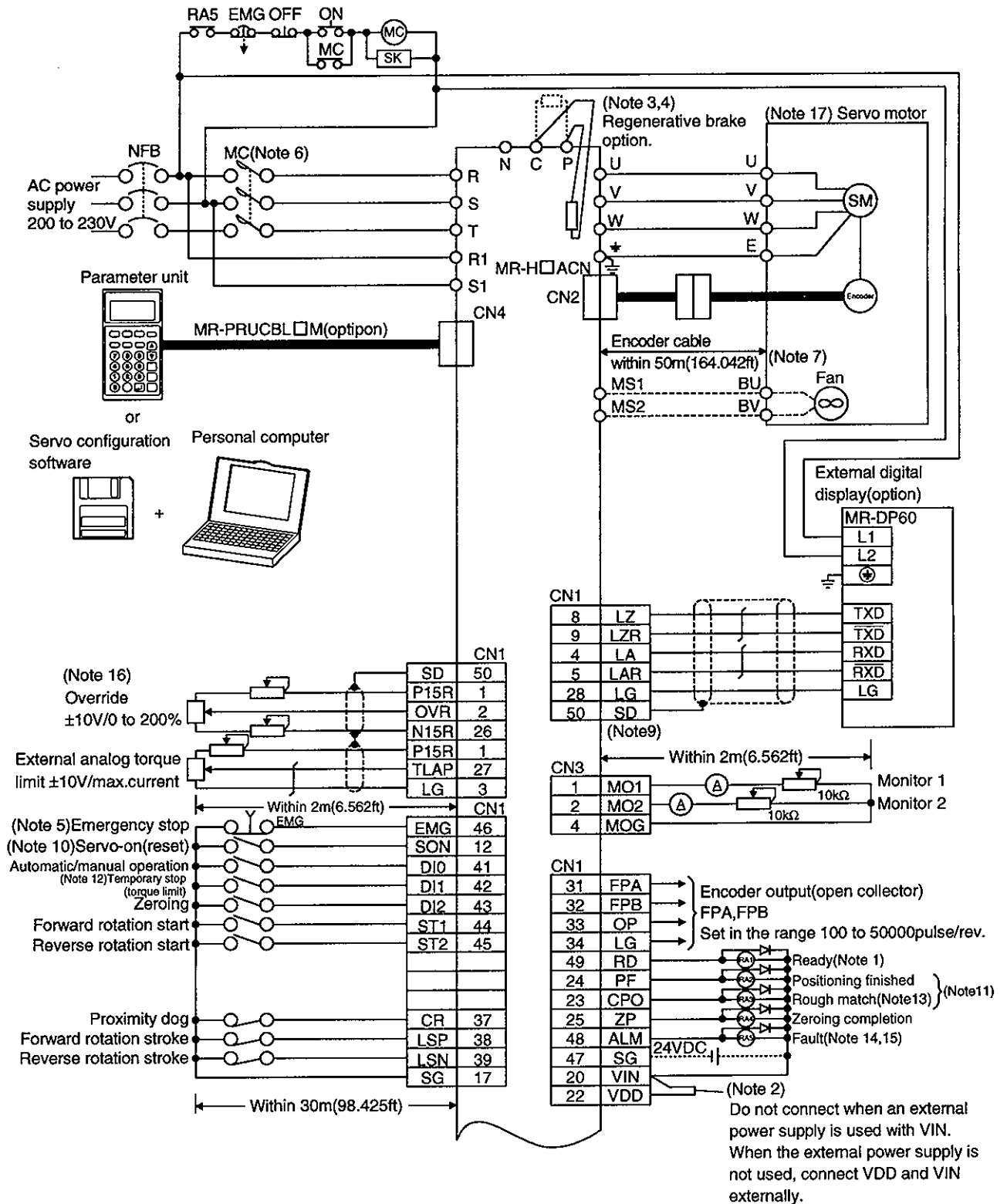
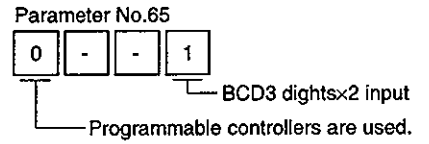

### 3. POSITIONING SYSTEM

When using the MR-H-D01 option card, set functions in parameters No. 65 to 68.

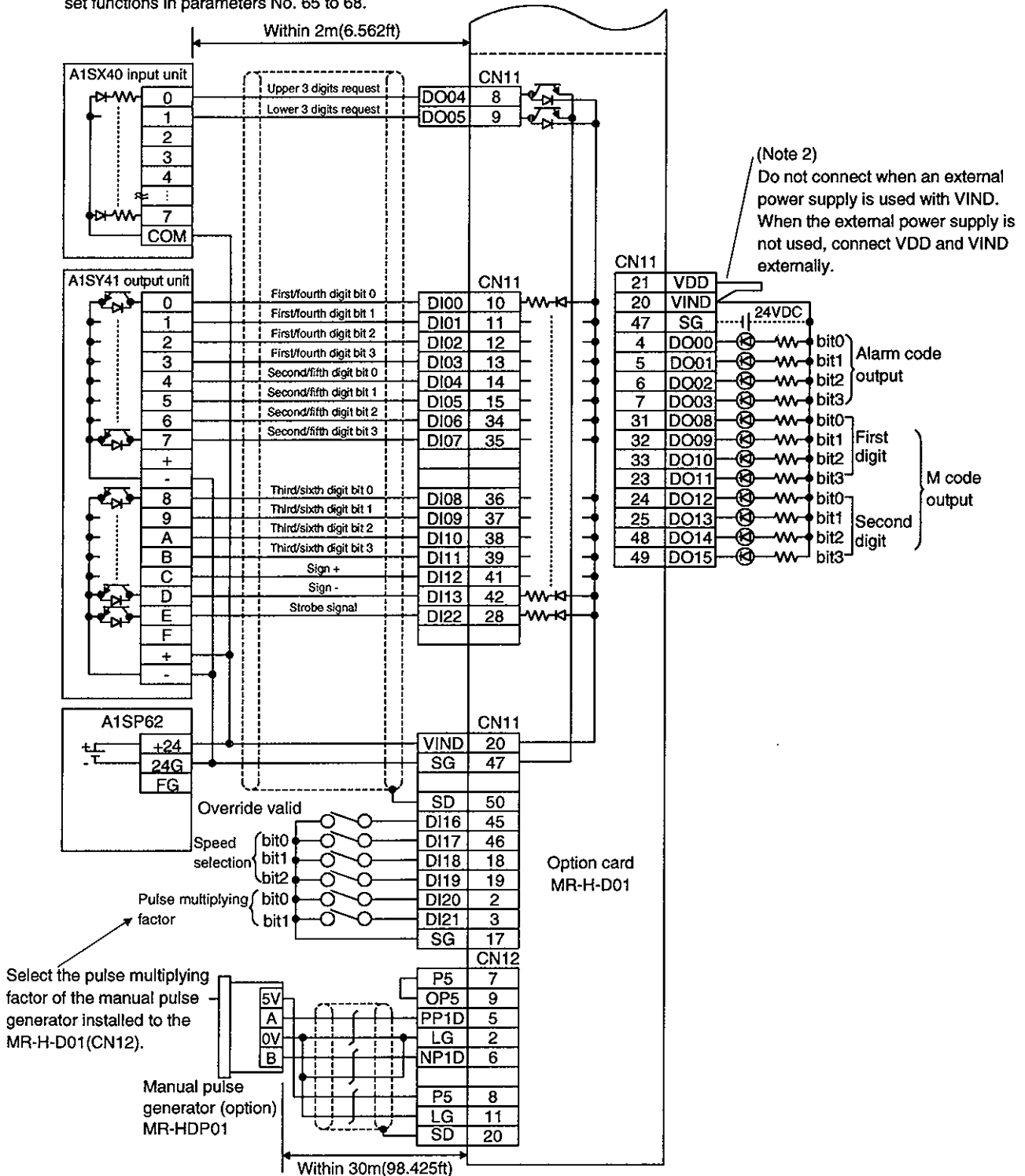

For notes, refer to page 3-10.

### 3. POSITIONING SYSTEM

---

- Note:
1. Connect the diode in the correct orientation. If the diode is reversed, a fault will occur and signals not output, and the emergency stop and other protective circuits may be disabled.
  2. The sum total of currents flowing in the external relays should be 200mA max. If 200mA is exceeded, supply external power to the interface.
  3. The controller of 11kW or more dose not contain the regenerative brake resistor. Connect the supplied external regenerative brake resistor.
  4. Connect the regenerative brake option across terminals P-C after disconnecting the leads of the built-in regenerative brake resistor from P-C.
  5. The emergency stop switch must be installed.
  6. Make up a power circuit which will switch off the magnetic contactor after detection of alarm occurrence.
  7. For the HA-LH series servo motors of 11kW or more, supply power to the fan terminals. For 11kW or more, connect the fan terminals to the MS1 and MS terminals of the controller. Refer to Section 5.4.4 for connection with the servo motor.
  8. When the MR-H-D01 option card is used, power can be supplied from the MR-H-D01.
  9. Change the setting of parameter No.52 to □□□0 to use LA, LAR, LB, LBR, LZ and LZR as encoder pulse outputs.
  10. Change the setting of parameter No.41 to □□□1 to use SON as a reset signal.
  11. Change the setting of parameter No.44 to □□□1 to use PF and CPO as an M code.
  12. Change the setting of parameter No.41 to □0□□ to use DI1 as a torque limit signal.
  13. Change the setting of parameter No.3 to □□1□ to use CPO as an electromagnetic brake interlock or the setting of parameter No.44 to □1□□ to use CPO as a torque limit-in-progress.
  14. Change the setting of parameter No.44 to □□1□ to use ALM as an pre-alarm output.
  15. The trouble (ALM) signal is on under normal conditions.
  16. The upper limit of the overriding speed is the permissible speed.
  17. The connection method changes with the servo motor series. Refer to Section 5.4.

### 3. POSITIONING SYSTEM

#### 3.3 I/O Connectors

##### 3.3.1 Connector signal layouts

**POINT**

- The signal layouts of the connectors are views from the wiring section of the cable connectors.

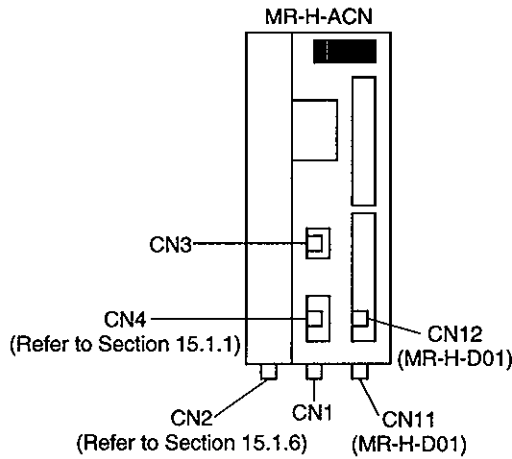

**CN2 (for encoder signals)**  
Model PCR-S20FS (Honda Tsushin make)

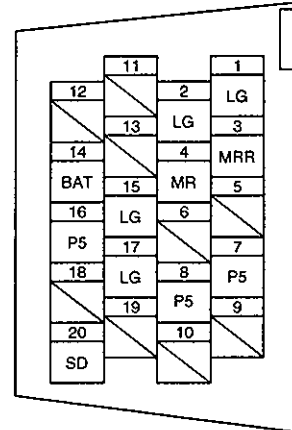

**CN1**  
Model PCR-S50FS (Honda Tsushin make)

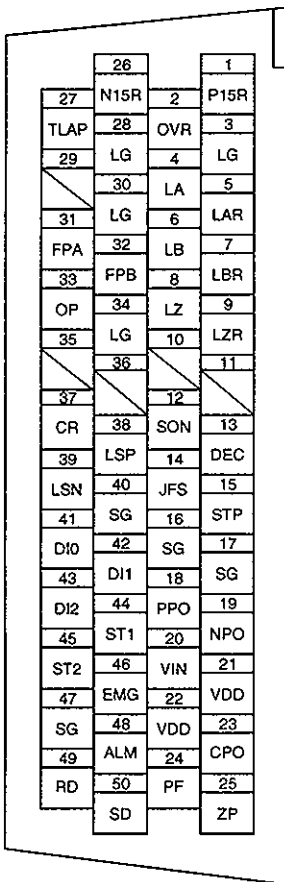

**CN11 (MR-H-D01 option card)**  
Model PCR-S50FS (Honda Tsushin make)

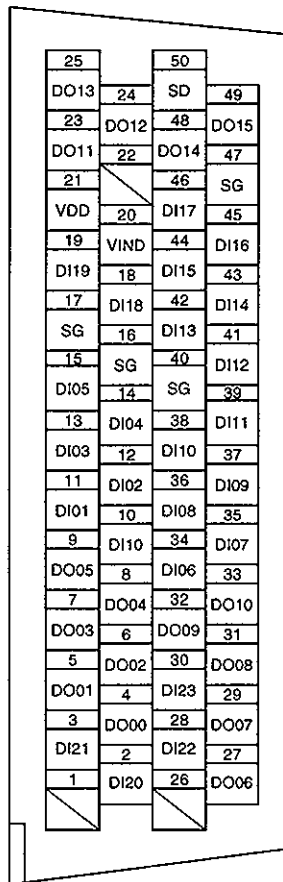

**CN12 (MR-H-D01 option card)**  
Model PCR-S20FS (Honda Tsushin make)

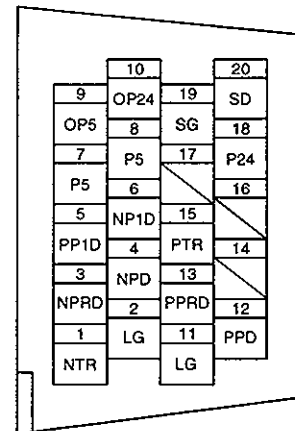

**CN3**  
Model 171822-4 (AMP make)

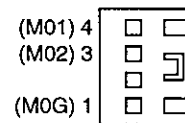

### 3. POSITIONING SYSTEM

#### 3.3.2 Signal explanations

Refer to Section 5.2.2 for the I/O interfaces (symbols in the I/O column in the table).

##### (1) CN1

Signal Name	Pin Code	Pin No.	Function/Application	I/O Category
Digital I/F power supply input	VIN	20	Driver power supply input terminal for digital interface Input 24VDC±10% for input interface. When using an external power supply, connect a 24VDC power supply of 200mA or more to this terminal. When using the internal power supply (VDD) as the interface power supply, always connect VDD.	
Driver power supply	VDD	21,22	+24V±10% is output across VDD-SG. Connect with VIN when using this power supply for the digital interface. Permissible current: 200mA	
Open collector power input	OPC	11	When using a manual pulse generator, supply 24VDC to this terminal.	
24V common	SG	16,17 40,47	Common terminals for VDD and VIN. Isolated from LG.	
DC power supply	P15R	1	+15VDC is output across P15R-LG. Use as a power supply for OVR/TLAP. Permissible current: 30mA	
	P15N	26	-15VDC is output across P15N-LG. Use as a power supply for OVR/TLAP. Permissible current: 30mA	
Control common	LG	3,28 30,34	Common terminals for OVR, TLAP, LA, LAR, LB, LBR, LZ, LZR, FPA, FPB and OP.	
Shield	SD	50	Connect the servo amplifier end of the shield cable.	
Servo on	SON	12	Operation-ready signal input terminal. Short SON-SG to switch the base circuit on, making the servo amplifier ready to operate. Open them to shut off the base circuit, coasting the servo motor.	DI-1
Reset			Alarm reset signal input terminal. When using the reset signal, set □□□1 in parameter No. 41. At this time, the servo on signal is "automatically turned on internally". Short SON-SG for longer than 20ms to reset the alarm. While SON-SG are shorted, the base circuit is shut off. However, regenerative alarm (AL 30), overload 1 (AL 50) and overload 2 (AL 51) cannot be reset until the regenerative brake resistor and power transistor temperatures reduce. The following alarms can be reset.	DI-1

Display	Name	Display	Name
AL10	Undervoltage	AL45	Main circuit device overheat
AL24	Ground fault	AL46	Servo motor overheat
AL31	Overspeed	AL52	Error excessive
AL32	Overcurrent	AL73	Auxiliary pulse frequency alarm
AL33	Overvoltage	AL75	Option memory alarm 2
AL35	Command pulse frequency alarm	AL8E	RS-232C alarm
AL42	Feedback alarm	AL8F	RS-422 alarm

### 3. POSITIONING SYSTEM

Signal Name	Pin Code	Pin No.	Function/Application	I/O Category																																				
Forward rotation start	ST1	44	<p>Forward rotation start signal input terminal in incremental command system. In the automatic operation mode, short ST1-SG to start rotation in the forward rotation direction. In the zeroing mode, short ST1-SG to start zeroing. In the jog operation mode, short ST1-SG to perform rotation in the forward rotation direction while they are shorted. Note: Forward rotation is in address increasing direction.</p> <p>Forward rotation start signal input terminal in absolute command system. In the automatic operation mode, short ST1-SG to make a start. In the zeroing mode, short ST1-SG to start zeroing. In the jog operation mode, short ST1-SG to perform rotation in the forward rotation direction while they are shorted. Note: Forward rotation is in address increasing direction.</p>	DI-1																																				
Reverse rotation start	ST2	45	<p>Reverse rotation start signal input terminal. In the automatic operation mode, short ST2-SG to start rotation in the reverse rotation direction. (Incremental command only) In the jog operation mode, short ST2-SG to perform rotation in the reverse rotation direction while they are shorted. Note: Reverse rotation is in address decreasing direction.</p>	DI-1																																				
Automatic/manual selection	DI0	41	<p>Automatic/manual mode selection signal input terminal. Short DI0-SG to choose the automatic operation mode or open them to choose the manual operation mode.</p>	DI-1																																				
Zeroing	DI2	43	Zeroing signal input terminal	DI-1																																				
Temporary stop	DI1	42	<p>Temporary stop signal input terminal When DI1-SG are open, short them to stop operation. Short the open start signal again to resume operation from where it had stopped. Reserve the pulse width of 5ms or longer.</p>	DI-1																																				
Torque limit			<p>Torque limit signal input terminal. When using the torque limit signal, set □0□□ in parameter No. 41. At this time, the temporary stop signal is made invalid. Short DI1-SG to limit the generated torque according to the voltage of the torque limit command (TLP). Open DI1-SG to make the parameter No. 40 setting valid.</p>	DI-1																																				
Position block number selection 1	DEC	13	<p>No. selection signal input terminals. The position block No.s chosen by the combinations of DEC, JFS and STP are listed below:</p> <table border="1" style="margin-left: auto; margin-right: auto;"> <thead> <tr> <th>STP</th> <th>JFS</th> <th>DEC</th> <th>Selected Position Block No.</th> </tr> </thead> <tbody> <tr><td>0</td><td>0</td><td>0</td><td>No.0</td></tr> <tr><td>0</td><td>0</td><td>1</td><td>No.1</td></tr> <tr><td>0</td><td>1</td><td>0</td><td>No.2</td></tr> <tr><td>0</td><td>1</td><td>1</td><td>No.3</td></tr> <tr><td>1</td><td>0</td><td>0</td><td>No.4</td></tr> <tr><td>1</td><td>0</td><td>1</td><td>No.5</td></tr> <tr><td>1</td><td>1</td><td>0</td><td>No.6</td></tr> <tr><td>1</td><td>1</td><td>1</td><td>No.7</td></tr> </tbody> </table> <p>Note: 0. Any terminal-SG OFF (open) 1. Any terminal-SG ON (short)</p>	STP	JFS	DEC	Selected Position Block No.	0	0	0	No.0	0	0	1	No.1	0	1	0	No.2	0	1	1	No.3	1	0	0	No.4	1	0	1	No.5	1	1	0	No.6	1	1	1	No.7	DI-1
STP	JFS	DEC		Selected Position Block No.																																				
0	0	0		No.0																																				
0	0	1		No.1																																				
0	1	0	No.2																																					
0	1	1	No.3																																					
1	0	0	No.4																																					
1	0	1	No.5																																					
1	1	0	No.6																																					
1	1	1	No.7																																					
Position block number selection 2	JFS	14																																						
Position block selection number 3	STP	15																																						



### 3. POSITIONING SYSTEM

Signal Name	Pin Code	Pin No.	Function/Application	I/O Category																								
Proximity dog	CR	37	<p>Proximity dog signal input terminal for manual zeroing. Short CR-SG to detect the proximity dog. The polarity of dog detection can be changed with the parameter.</p> <table border="1"> <thead> <tr> <th>Parameter No. 9</th> <th>Polarity of Proximity Dog Detection</th> </tr> </thead> <tbody> <tr> <td><input type="checkbox"/>0<input type="checkbox"/></td> <td>CR-SG open</td> </tr> <tr> <td><input type="checkbox"/>1<input type="checkbox"/> (initial value)</td> <td>CR-SG shorted</td> </tr> </tbody> </table>	Parameter No. 9	Polarity of Proximity Dog Detection	<input type="checkbox"/> 0 <input type="checkbox"/>	CR-SG open	<input type="checkbox"/> 1 <input type="checkbox"/> (initial value)	CR-SG shorted	DI-1																		
Parameter No. 9	Polarity of Proximity Dog Detection																											
<input type="checkbox"/> 0 <input type="checkbox"/>	CR-SG open																											
<input type="checkbox"/> 1 <input type="checkbox"/> (initial value)	CR-SG shorted																											
Forward rotation stroke end	LSP	38	<p>Stroke end signal input terminals. To start operation, short LSP-SG and/or LSN-SG. Open them to bring the motor to a sudden stop and make it servo-locked. When these signals are not used, choose "automatically turned on internally" in parameter No. 42.</p>	DI-1																								
Reverse rotation stroke end	LSN	39	<table border="1"> <thead> <tr> <th colspan="2">(Note) External Input Signals</th> <th colspan="2">Operation</th> </tr> <tr> <th>LSP</th> <th>LSN</th> <th>CCW direction</th> <th>CW direction</th> </tr> </thead> <tbody> <tr> <td>1</td> <td>1</td> <td>○</td> <td>○</td> </tr> <tr> <td>0</td> <td>1</td> <td><del>○</del></td> <td>○</td> </tr> <tr> <td>1</td> <td>0</td> <td>○</td> <td><del>○</del></td> </tr> <tr> <td>0</td> <td>0</td> <td><del>○</del></td> <td><del>○</del></td> </tr> </tbody> </table> <p>Note: 0. LSP/LSN-SG off (open) 1. LSP/LSN-SG on (short)</p>	(Note) External Input Signals		Operation		LSP	LSN	CCW direction	CW direction	1	1	○	○	0	1	<del>○</del>	○	1	0	○	<del>○</del>	0	0	<del>○</del>	<del>○</del>	DI-1
(Note) External Input Signals		Operation																										
LSP	LSN	CCW direction	CW direction																									
1	1	○	○																									
0	1	<del>○</del>	○																									
1	0	○	<del>○</del>																									
0	0	<del>○</del>	<del>○</del>																									
Manual pulse generator signal	PPO	18	Connect the manual pulse generator (MR-HDP01).	DI-2																								
	NPO	19	Refer to Section 15.1.12 for details.																									
Emergency stop	EMG	46	<p>Emergency stop signal input terminal Opening EMG-SG puts the motor in an emergency stop status, in which the servo is switched off, the dynamic brake is operated, and the motor comes to a sudden stop. Short EMG-SG in the emergency stop status to exit from the emergency stop status.</p>	DI-1																								
Trouble	ALM	48	<p>Trouble signal output terminal. ALM-SG are disconnected when the protective circuit is activated to shut off the base circuit at power-off or power-on. They are connected in a normal status at power-on</p>	DO-1																								
Rough match	CPO	23	<p>Rough match signal output terminal. CPO-SG are connected when the command remaining distance is less than the rough match output range set in the parameter. Not output while the base circuit is on.</p>	DO-1																								
Limiting torque			<p>Limiting torque signal output terminal. When using the limiting torque signal, make it valid in parameter No. 44. At this time, the rough match/electromagnetic brake interlock signal is made invalid. CPO-SG are connected when the internally or externally set torque limit value is reached.</p>	DO-1																								
Electromagnetic brake inter lock			<p>Electromagnetic brake interlock output signal terminal. When using the electromagnetic brake interlock signal, make it valid in parameter No. 3. At this time, the rough match/limiting torque signal is made invalid. The electromagnetic brake interlock signal is output. CPO-SG are disconnected at servo off or alarm.</p>	DO-1																								
In position	PF	24	<p>In-position signal output terminal. PF-SG are connected when the droop pulse value is less than the in-position range set in the parameter. Not output while the base circuit is off.</p>	DO-1																								

### 3. POSITIONING SYSTEM

Signal Name	Pin Code	Pin No.	Function/Application	I/O Category														
Zeroing completion	ZP	25	ZP-SG are connected on completion of zeroing. In the absolute position system, ZP-SG are connected when operation is made ready, but are disconnected if: 1) SON-SG are opened; 2) EMG-SG are opened; 3) SON-SG are shorted when SON has been changed into the reset signal; 4) Alarm occurs; 5) Limit switch is opened;	DO-1														
Ready	RD	49	Ready output terminal. After servo on, RD-SG are connected in a trouble-free ready status.	DO-1														
M code bit0	PF	24	When using these signals, make them valid in parameter No. 44. M code is output in 2-bit binary.	DO-1														
M code bit1	CPO	23	<table border="1" style="margin-left: auto; margin-right: auto;"> <thead> <tr> <th rowspan="2">M Code</th> <th colspan="2">(Note) Output Signals</th> </tr> <tr> <th>CPO</th> <th>PF</th> </tr> </thead> <tbody> <tr> <td>0</td> <td>0</td> <td>0</td> </tr> <tr> <td>1</td> <td>0</td> <td>1</td> </tr> <tr> <td>2</td> <td>1</td> <td>0</td> </tr> </tbody> </table> <p>Note: 0. CPO/PF-SG OFF (disconnected) 1. CPO/PF-SG ON (connected)</p>	M Code	(Note) Output Signals		CPO	PF	0	0	0	1	0	1	2	1	0	DO-1
M Code	(Note) Output Signals																	
	CPO	PF																
0	0	0																
1	0	1																
2	1	0																
Encoder pulse (open collector)	FPA FPB	31 32	In CCW rotation of the servo motor, FPA leads FPB by $\pi/2$ . Pulses are output in the range 100 to 5000 pulses/rev according to the parameter No. 39 setting.	DO-2														
Encoder Z-phase pulse (differential line driver)	OP	33	Z-phase pulse signal output terminal. Output the zero-point signal of the servo motor encoder. OP-SG are connected in the zero-point position. The minimum pulse width is approx 1.77ms.	DO-2														
External digital display signal	LA LAR LZ LZR	4 5 8 9	External digital display signal output terminal. When using the MR-DP60 external digital display, connect it to this terminal.	DO-2														
Encoder pulse (differential line driver)	LA LAR LB LBR	4 5 6 7	When using the encoder output signal (differential line driver system), make it valid in parameter No. 52.	DO-2														
Override	OVR	2	Apply -10 to +10V across OVR-LG to limit the servo motor speed. 0[%] for -10[V], 100[%] for 0[V], 200[%] for 10[V].	Analog input														
External analog torque limit	TLAP	27	Apply 0 to +10V across TLAP-LG to limit the servo motor-generated torque. Zero torque for 0[V], max. torque for 10[V].	Analog input														

### 3. POSITIONING SYSTEM

#### (2) CN11 (MR-H-D01)

Pin Code	Pin No.	Functions and Applications		I/O (Note)
		256-position point data command	Position data command	
D004	8		Position data common 1 terminal (sign. 6th digit, 5th digit, 4th digit)	
D005	9		Position data common 2 terminal (3rd digit, 2nd digit, 1st digit)	
DI00	10	Position block number input terminal, 8-bit binary bit 0	Position data input terminal (1st digit, 4th digit, 4-bit binary bit 0)	DI-1
DI01	11	Position block number input terminal, 8-bit binary bit 1	Position data input terminal (1st digit, 4th digit, 4-bit binary bit 1)	DI-1
DI02	12	Position block number input terminal, 8-bit binary bit 2	Position data input terminal (1st digit, 4th digit, 4-bit binary bit 2)	DI-1
DI03	13	Position block number input terminal, 8-bit binary bit 3	Position data input terminal (1st digit, 4th digit, 4-bit binary bit 3)	DI-1
DI04	14	Position block number input terminal, 8-bit binary bit 4	Position data input terminal (2nd digit, 5th digit, 4-bit binary bit 0)	DI-1
DI05	15	Position block number input terminal, 8-bit binary bit 5	Position data input terminal (2nd digit, 5th digit, 4-bit binary bit 1)	DI-1
DI06	34	Position block number input terminal, 8-bit binary bit 6	Position data input terminal (2nd digit, 5th digit, 4-bit binary bit 2)	DI-1
DI07	35	Position block number input terminal, 8-bit binary bit 7	Position data input terminal (2nd digit, 5th digit, 4-bit binary bit 3)	DI-1
DI08	36		Position data input terminal (3rd digit, 6th digit, 4-bit binary bit 0)	DI-1
DI09	37		Position data input terminal (3rd digit, 6th digit, 4-bit binary bit 1)	DI-1
DI10	38		Position data input terminal (3rd digit, 6th digit, 4-bit binary bit 2)	DI-1
DI11	39		Position data input terminal (3rd digit, 6th digit, 4-bit binary bit 3)	DI-1
DI12	41		Position data input terminal (sign +)	DI-1
DI13	42		Position data input terminal (sign -)	DI-1
DI16	45	Override selection input terminal		DI-1
DI17	46	Speed selection input terminal, 3-bit binary bit 0		DI-1
DI18	18	Speed selection input terminal, 3-bit binary bit 1		DI-1
DI19	19	Speed selection input terminal, 3-bit binary bit 2		DI-1
DI20	2	Manual pulse generator magnification selection input terminal, 2-bit binary bit 0		DI-1
DI21	3	Manual pulse generator magnification selection input terminal, 2-bit binary bit 1		DI-1
DI22	28		Strobe input terminal (not required when the 6-digit digital switch is used)	DI-1
DO00	4	Alarm code output terminal, 4-bit binary bit 0		DO-2
DO01	5	Alarm code output terminal, 4-bit binary bit 1		DO-2
DO02	6	Alarm code output terminal, 4-bit binary bit 2		DO-2
DO03	7	Alarm code output terminal, 4-bit binary bit 3		DO-2
DO08	31	M code output terminal, 1st digit, 4-bit binary bit 0		DO-2
DO09	32	M code output terminal, 1st digit, 4-bit binary bit 1		DO-2
DO10	33	M code output terminal, 1st digit, 4-bit binary bit 2		DO-2
DO11	23	M code output terminal, 1st digit, 4-bit binary bit 3		DO-2
DO12	24	M code output terminal, 2nd digit, 4-bit binary bit 0		DO-2
DO13	25	M code output terminal, 2nd digit, 4-bit binary bit 1		DO-2
DO14	48	M code output terminal, 2nd digit, 4-bit binary bit 2		DO-2
DO15	49	M code output terminal, 2nd digit, 4-bit binary bit 3		DO-2
VDD	21	24VDC output terminal		
VIND	20	Connect with VDD or connect an external power supply		
SG	16,17 40,47	24VDC common terminal	Common terminal for 24VDC except position data	
SD	50	Shielding terminal		

### 3. POSITIONING SYSTEM



#### (3) CN12 (Connector for connection of MR-H-D01/manual pulse generator)









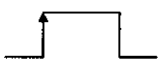
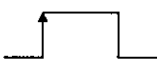

Pin Code	Pin No.	Functions and Applications		I/O (Note)
		256-position point data command	Position data command	
PP1D	5	Open collector forward rotation pulse input terminal		DI-2
PN1D	6	Open collector reverse rotation pulse input terminal		DI-2
P5	7,8	5VDC output terminal		
OP5	9	Connect with P5 or connect an external power supply		
LG	2,11	5VDC common terminal		
SD	20	Shielding terminal		

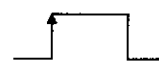
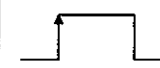
#### 3.3.3 Control input/output signals

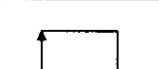
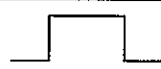
##### (1) Start signals and operation mode select signals

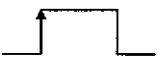
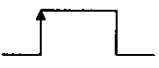
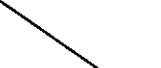
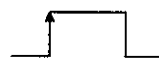
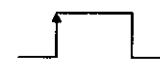
The start signals change as indicated below depending on the operation mode selection conditions.

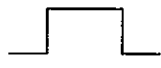
Indicates that the signal is made valid when it is switched from off to on, and  is invalid if switched on during operation. Indicates that the signal is valid while it is on, and  is made invalid when switched off.

Signal		Operation mode		Automatic Operation		Manual Operation	Manual Zeroing	Automatic Positioning to Home Position
		Automatic/Manual Operation	DI0	Absolute command	Incremental command			
CN1	Automatic/Manual Operation	DI0	ON	ON	OFF	OFF	ON	ON
	Zeroing	DI2	OFF	OFF	OFF	ON	ON	ON
	Forward rotation start	ST1			 (Forward rotation JOG)		 (First zeroing)	
	Reverse rotation start	ST2			 (Reverse rotation JOG)		 (Second zeroing)	
	Temporary stop	DI1						
Manual pulse generator								

Note: If you turn on-off DI0/DI2 during operation in the automatic operation mode, the operation mode cannot be changed. The operation mode is switched to the one specified by DI0 and DI2 after completion of positioning to the target position.

### 3. POSITIONING SYSTEM

#### (2) Start and stop signals

- 1) Make up the sequence so that the start signal is switched on after the main circuit has been set up. The start signal is invalid if it is switched on before the main circuit is set up. Normally interlock is provided between the start signal and ready signal (RD).
- 2) The controller is started when the start signal is switched from off to on. The internal processing of the controller delays 3ms maximum. The other signal delays 10ms maximum.

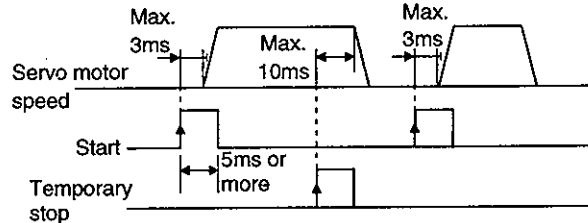

- 3) When using the programmable controller, set the ON time of the start/stop signal to 5ms or longer to prevent a malfunction.
- 4) The start signal (ST1/ST2) is not accepted during operation. The next operation must be started after the rough match signal has been output with the rough match output range set to zero, or after the in-position signal has been output.

#### (3) Proximity dog (CR)

Used for dog type and count type manual zeroing as a proximity dog detection signal. Keep this signal on during operation and switch it off when the proximity dog is detected.

#### (4) Zeroing completion (ZP)

Switched on after completion of manual zeroing performed with power on.

After that, kept on independently of the zeroing method. Use the zeroing completion signal (ZP) when making a zeroing request signal for interlock, for example.

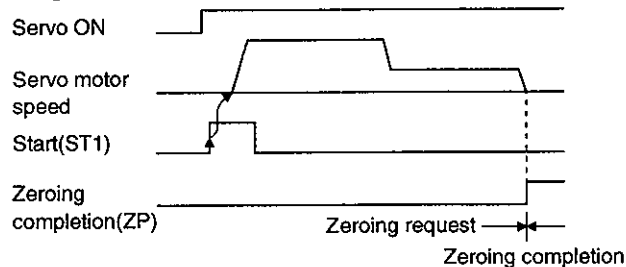

#### (5) Positioning completion signal (PF)

Switched on when the droop of the deviation counter falls within the present positioning completion range (parameter No.16). When operation is performed at low speed, the low droop may keep the PF signal on if the positioning completion range (parameter No.16) setting is large.

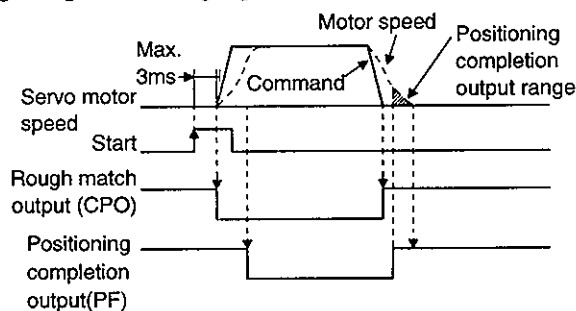

#### (6) Rough match (CPO)

Switched on when the command remaining distance is less than the rough match output range (parameter No. 17). Refer to the timing chart in (5) of this section.

### 3. POSITIONING SYSTEM

#### (7) Override (OVR)

The override (OVR) may be used to change the servo motor speed. The following table lists the signals and parameter related to the override:

Item	Name	Remarks
Analog input signal	Override (OVR)	
Contact input signal	Override selection (DI16)	MR-H-D01 option card used
Parameter	No.24 function selection 5	<input type="checkbox"/> <input type="checkbox"/> <input type="checkbox"/> 1 : Override used
	No.47 override offset	-9999 to 9999mV

To use override, make it available by setting 1 in parameter No. 24.

#### (a) Override (OVR)

By applying a voltage (-10 to +10V) to the override (OVR) terminal, change values can be set from outside consecutively. The following graph shows the relationship between the input voltage and the ratio of actual speed to preset speed.

Refer to the following diagram when using the 15V power output (P15R/N15R) of the controller:

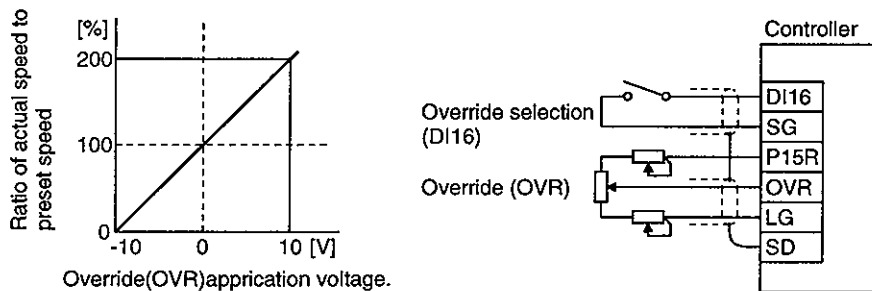

#### (b) Override selection (DI16)

Used to make the override (OVR) valid or invalid. The MR-H-D01 option card is required to use this signal. Set 1 in parameter No. 66 to make override selection valid.

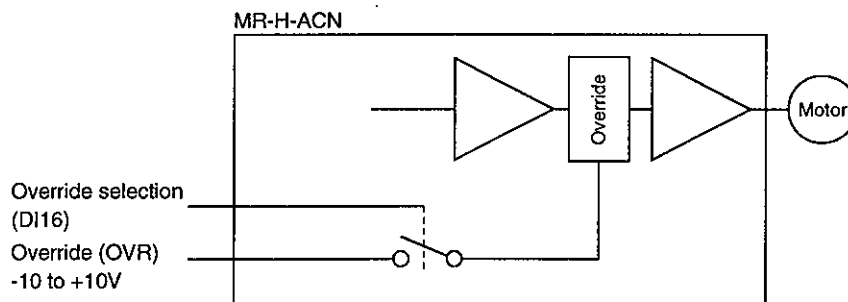

Using the override selection (DI16), choose a change value as follows:

Across DI16-SG	Speed Change Value
Open	No change
Short	Override (OVR) setting is made valid.

#### (c) Override offset (parameter No.47)

Using parameter No.47, the offset voltage can be set relative to the input voltage for the override (OVR). The setting is between -9999 to 9999mV.

### 3. POSITIONING SYSTEM

#### (8) Torque limit

The following table lists the signals and parameters related to the torque limit:

Item	Name	Remarks
Analog input signal	External torque limit (TLAP)	
Contact input signals	Torque limit selection (DI1)	Set □0□□ (initial value) in parameter No. 41.
Contact output signal	Limiting torque (CPO)	
Parameters	No.40 internal torque limit	0 to 100%
	No.54 internal torque limit 2	0 to 100%
	No.48 torque limit offset	-9999 to 9999mV
	No.41 input signal selection	Selection of torque limit value to be used

The torque limit is available in two types: internal torque limit set in parameters and external torque limit using analog input signal. This function limits generated torque on the assumption that the maximum torque of the servo motor is 100%.

#### (a) Internal torque limits (parameter No.40,54)

Use parameter No.40 and 54 to set the internal torque limit values. The following graph shows the generated torque relative to the setting.

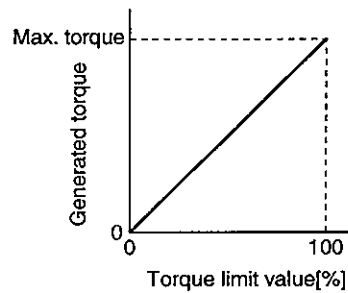

#### (b) External torque limit (TLAP)

By applying a voltage (0 to +10V) to the external torque limit (TLAP) terminal, limit values can be set from outside consecutively. The following graph shows the relationship between input voltage and limit value.

Depending on the controller, the limit value has about 5% variations to the input voltage.

As this may not cause torque to be limited sufficiently at less than 0.05V, use this function at the voltage of 0.05V or more.

Refer to the following diagram when using the 15V power output (P15R) of the controller:

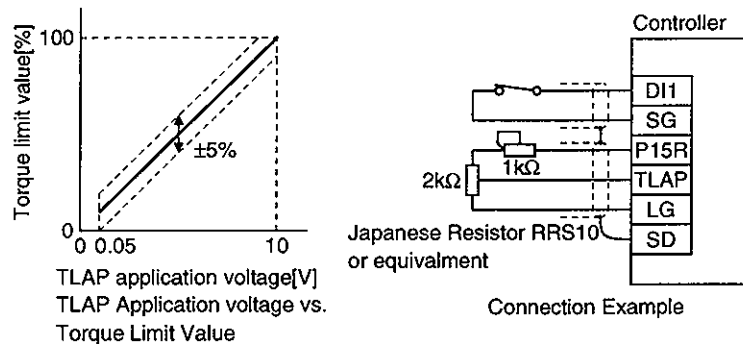

### 3. POSITIONING SYSTEM

(c) Torque limit selection (DI1)

To use torque limit selection (DI1), set □0□□ in parameter No. 41.

This input signal can be used to choose the torque limit value made valid. When not using torque limit selection (DI1), set □1□□ (initial value) in parameter No. 41. At this time, the internal torque limit (parameter No. 40) setting is always made valid.

1) When □0□□ is set in parameter No. 41

Switched between external torque limit (TLAP) and internal torque limit (parameter No. 40).

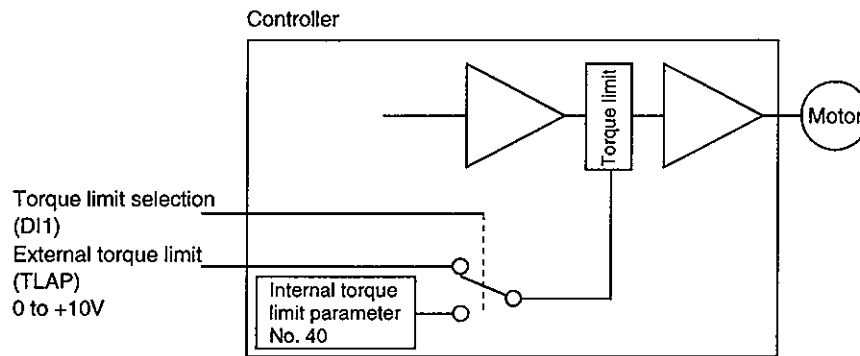

Using the internal torque limit selection (DI1), choose the limit value as follows. When DI1-SG are shorted, the smaller value of the external torque limit and internal torque limit is chosen:

Across DI1-SG	Torque Limit Value
Open	External torque limit (TLAP) if External torque limit (TLAP) < internal torque limit
	Internal torque limit if External torque limit (TLAP) > internal torque limit
Short	Internal torque limit



### 3. POSITIONING SYSTEM

2) When  $\square\square 1\square$  is set in parameter No. 41

Switched between internal torque limit (parameter No. 40) and internal torque limit 2 (parameter No. 54).

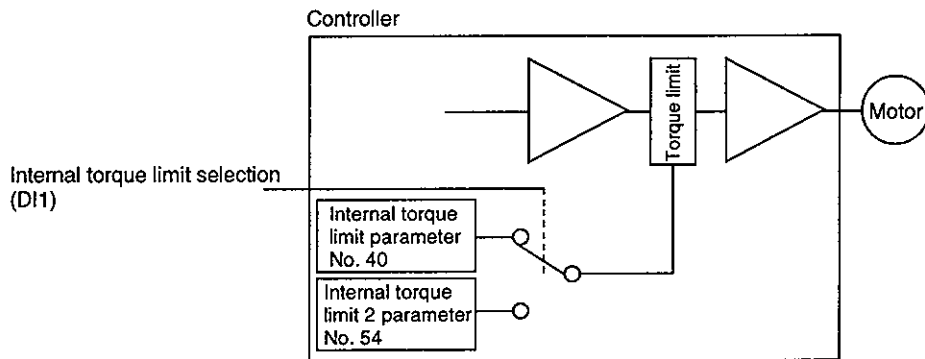

Using the internal torque limit selection (DI1), choose the limit value as follows. When DI1-SG are shorted, the smaller value of the internal torque limit and internal torque limit 2 is chosen:

Across DI1-SG	Torque Limit Value
Open	Internal torque limit
Short	Internal torque limit if internal torque limit < internal torque limit 2
	Internal torque limit 2 if internal torque limit > internal torque limit 2

(9) Stroke ends (LSP,LSN)

During operation, use limit switches or the like with LSP and LSN to connect with SG. On a machine which dose not have stroke ends, connect LSP and LSN with SG. If they are not connected, the servo motor will not rotate. Disconnection of LSP or LSN from SG during rotation of the servo motor (LSP during CCW rotation, LSN during CW rotation) causes the servo motor to be brought to a sudden stop and servo-locked. At this time, the deviation counter is cleared.

(10) M code output

1) Standard (0 to 2)

When  $\square\square\square 1$  is set in parameter No.44, the M code is output in 2-bit binary from CPO and PF.

M code	CPO	PF
0	0	0
1	0	1
2	1	0

Note: 0. CPO/PF-SG OFF

1. CPO/PF-SG ON

### 3. POSITIONING SYSTEM

2) When option card (MR-H-D01) is used (00 to 99)

When  is set in parameter No.67, the 1st digit of M code is output from DO08, DO09, DO10 and DO11 of the MR-H-D01, and the 2nd digit from DO12, DO13, DO14, and DO15, in 4-bit binary.

M code	1st digit	DO11	DO10	DO09	DO08
	2nd digit	DO15	DO14	DO13	DO12
0	0	0	0	0	0
1	0	0	0	0	1
2	0	0	0	1	0
3	0	0	0	1	1
4	0	0	1	0	0
5	0	0	1	0	1
6	0	0	1	1	0
7	0	0	1	1	1
8	1	1	0	0	0
9	1	1	0	0	1

Note: 0. Any terminal-SG OFF (Open)

1. Any terminal-SG ON (Short)

For the M code output timing, refer to the timing chart in Section 3.4.3.

(11) Manual pulse generator pulse magnification selection (DI20,DI21)

Use the MR-H-D01 option card.

Set  in parameter No.65 to make this signal valid

Select the pulse magnification across DI20, DI21-SG as indicated in the following table.

Pulse Magnification	(Note) Input signal	
	DI21	DI20
1 time	0	0
10 times	0	1
100 times	1	0

Note: 0. DI21/DI20-SG OFF (Open)

1. DI21/DI20-SG ON (Short)

(12) Alarm code output (DO00,DO01,DO02,DO03)

Use the option card (MR-H-D01).

Set 1 in parameter No.67 to make this signal valid. The alarm type is output in 4-bit code. For more information, refer to Section 12.2.1

### 3. POSITIONING SYSTEM

#### (13) Strobe signal (DI22)

Use the MR-H-D01 option card.

When the programmable controller is used, this signal controls the read timing of position data. Position data is read in two parts separately:

lower 3 digits; and upper 3 digits + sign. Hence, the strobe signal must be switched on twice.

Provide position data and switch the strobe signal on with a delay of 5ms or more. Keep the strobe signal on for 5ms or more and keep the data unchanged during this period. The relationship between the position data and start signal (ST1, ST2) should be as shown in the following timing chart. Two or more pieces of position data cannot be read. After one piece of position data has been read, switch on the start signal.

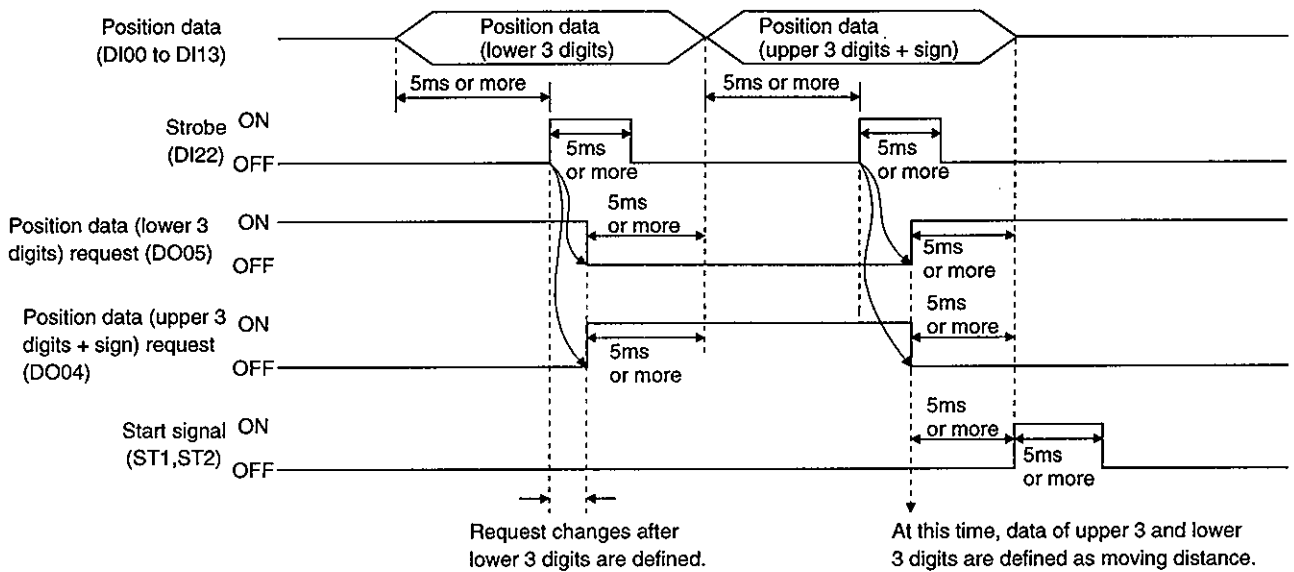

#### (14) External speed setting (DI17, DI18, DI19)

The MR-H-D01 option card is used. Set 1 in parameter No. 65. Position block data need not be used to specify the speed block No., and the DI17, DI18, DI19 external input signal (3-bit binary) can be used to choose the speed block No.

Speed block No.	(Note) Input Signal		
	DI19	DI18	DI17
	bit2 (MSB)	bit1	bit0 (LSB)
1	0	0	0
2	0	0	1
3	0	1	0
4	0	1	1
5	1	0	0
6	1	0	1
7	1	1	0
8	1	1	1

Note: 0. Any terminal-SG OFF (Open)

1. Any terminal-SG ON (Short)

### 3. POSITIONING SYSTEM

---

#### 3.4 Operation

##### 3.4.1 When Switching Power On for the First Time

###### (1) Pre-operation checks

Before starting operation, check the following:

###### (a) Wiring

- 1) A correct power supply is connected to the power input terminals (R, S, T) of the controller.
- 2) The servo motor power supply terminals (U, V, W) of the controller match in phase with the power input terminals (U, V, W) of the servo motor.
- 3) The servo motor power supply terminals (U, V, W) of the controller are not shorted to the power input terminals (R, S, T).
- 4) The controller and servo motor are grounded securely.
- 5) When using the regenerative brake option, twisted cables are used and the lead of the built-in regenerative brake resistor has been removed.
- 6) When stroke end limit switches are used, the signals across LSP-SG and LSN-SG are on during operation.
- 7) 24VDC or higher voltages are not applied to the pins of connectors CN1.
- 8) SD and SG of connectors CN1 are not shorted.
- 9) The wiring cables are free from excessive force.

###### (b) Environment

Signal cables and power cables are not shorted by wire offcuts, metallic dust or the like.

###### (c) Machine

- 1) The screws in the servo motor installation part and shaft-to-machine connection are tight.
- 2) The servo motor and the machine connected with the servo motor can be operated.

### 3. POSITIONING SYSTEM

#### 3.4.2 Startup

#### ⚠ WARNING

- Do not operate the switches with wet hands. You may get an electric shock.
- Do not operate the controller with the front cover removed. High-voltage terminals and charging area are exposed and you may get an electric shock.
- During power-on or operation, do not open the front cover. You may get an electric shock.

#### ⚠ CAUTION

- Before starting operation, check the parameters. Some machines may perform unexpected operation.
- During power-on or soon after power-off, do not touch the servo amplifier heat sink, regenerative brake resistor, servo motor, etc. as they may be at high temperatures. You may get burnt.

Connect the servo motor with a machine after confirming that the servo motor operates properly alone. For startup reference, a single machine structure will be described. Refer to this section and start up the machine safely.

#### (1) Machine conditions

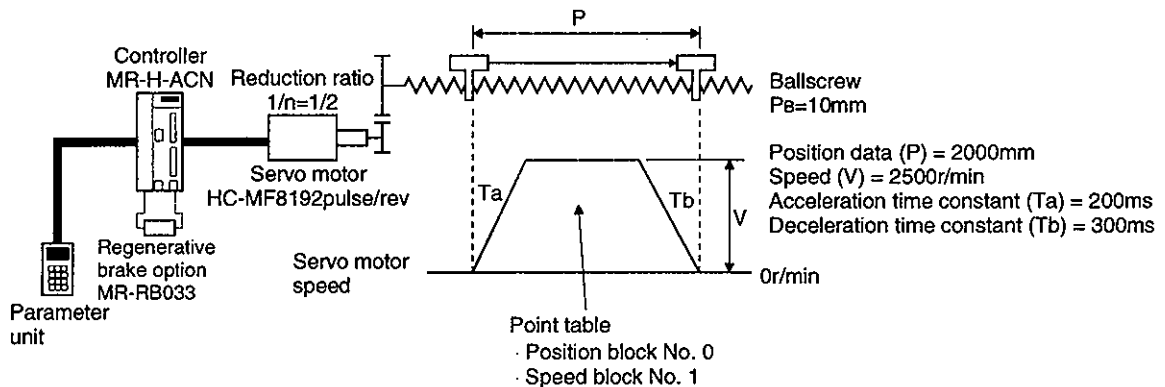

- 1) Absolute position detection system used
- 2) Command resolution: 10μm
- 3) Command system: Absolute value command system
- 4) Electronic gear calculation

$$\frac{\text{CMX (pulse)}}{\text{CDV (}\mu\text{m)}} = \frac{8192}{\frac{1}{n} \cdot P_B \cdot 1000} = \frac{8192}{\frac{1}{2} \cdot 10 \cdot 1000} = \frac{8192}{5000} \dots\dots\dots (3.1)$$

CMX=8192  
CDV=5000

- 5) Position block No.1 is used to execute automatic operation once.

### 3. POSITIONING SYSTEM

#### (2) Startup procedure

##### (a) Power on

- 1) Switch off the servo on (SON) signal.
- 2) When main circuit power/control circuit power is switched on, "Position" appears on the parameter unit display.

##### (b) Test operation 1

Using jog operation in the "test operation mode" of the parameter unit, make sure that the servo motor operates. (Refer to Section 7.2.)

##### (c) Parameter setting

Set the parameters according to the structure and specifications of the machine. Refer to Chapter 6 for the parameter definitions and to Sections 7.2 for the setting method.

Parameter	Name	Setting	Description
No.0	Motor series		Setting is not needed because of HA-FF series servo motor.
No.1	Motor type		Setting is not needed because of HA-FF series servo motor.
No.2	Feed system	<input type="checkbox"/> 3 <input type="checkbox"/> 2	<ul style="list-style-type: none"> <li>— Absolute command system.</li> <li>— MR-RB033 regenerative brake option is used.</li> </ul>
No.3	Function selection 1	1 <input type="checkbox"/> <input type="checkbox"/> 0	<ul style="list-style-type: none"> <li>— Linear acceleration/deceleration system.</li> <li>— Used in absolute position detection system.</li> </ul>
No.4	Function selection 2	<input type="checkbox"/> 001	<ul style="list-style-type: none"> <li>— As command resolution is 10<math>\mu</math>m, feed length multiplying factor of 10 times is chosen.</li> <li>— Position data unit [mm] is selected.</li> <li>— Digital display, automatic decimal point setting selection.</li> </ul>
No.5	Electronic gear numerator (CMX)	8192	From calculation result of formula (3.1)
No.6	Electronic gear denominator (CDV)	5000	From calculation result of formula (3.1)

After setting the above parameters, switch power off once. Then switch power on again to make the set parameter values valid.

##### (d) Position block setting

Set the position block according to the operation pattern. Refer to Section 3.4.4. for the position block details and to Section 3.6 for the setting method.

Setting of position block No.0

Position Data [ $\times 10^{\text{SM}}$ $\mu$ m]	M code	Speed Block No.
2000.00	00	1

Setting of speed block No.1

Servo Motor Speed [r/min]	Acceleration Time Constant [ms]	Deceleration Time Constant [ms]
2500	1000	1000

### 3. POSITIONING SYSTEM

(e) Servo on

Switch the servo on in the following procedure:

- 1) Switch on main circuit/control power.
- 2) Switch on the servo on signal (SON) (short SON-SG).

When placed in the servo-on status, the servo amplifier is ready to operate and the servo motor is locked.

(f) Zeroing

Before starting positioning operation, always make home position return. Refer to Section 3.4 for zeroing types. A parameter setting example for dog type zeroing is given here.

Parameter	Name	Setting	Description
No.9	Zeroing type	<input type="checkbox"/> 000	<ul style="list-style-type: none"> <li>— Dog type zeroing is selected.</li> <li>— Zeroing is started in address incremented direction.</li> <li>— Proximity dog signal is valid when DOG-SG are opened.</li> </ul>
No.11	Zeroing speed	1000	Motion is made up to proximity dog at 1000r/min.
No.12	Creep speed	10	Motion is made up to home position at 10r/min.
No.13	Zero shift distance	0	No zero shift
No.10	Zeroing position data		Zero address is entered automatically after zeroing.
No.14	Moving distance after proximity dog		Not used in dog type zeroing.

After setting the above parameters, switch power off once. Then switch power on again to make the set parameter values valid.

Set the input signals as listed below and switch on the forward rotation start (ST1) to execute zeroing.

Device Name	Symbol	ON/OFF	Description
Automatic/manual selection	DI0	OFF	Zeroing mode is selected.
Zeroing	DI2	ON	
Temporary stop	DI1	OFF	
Servo-on	SON	ON	Servo-on status is reached.

(g) Automatic operation

Set the input signals as listed below and switch on the forward rotation start (ST1) to execute automatic operation in accordance with point table No.0.

Device Name	Symbol	ON/OFF	Description
Automatic/manual selection	DI0	ON	Automatic operation mode is selected.
Servo-on	SON	ON	Servo-on status is reached.
Forward rotation stroke end	LSP	ON	Forward rotation side limit switch is turned on.
Reverse rotation stroke end	LSN	ON	Reverse rotation side limit switch is turned on.
Position block number selection 1	DEC	OFF	Position block No.0 is selected.
Position block number selection 2	JFS	OFF	
Position block number selection 3	STP	OFF	

### 3. POSITIONING SYSTEM

---

(h) Stop

In any of the following statuses, the controller interrupts and stops the operation of the servo motor:

1) Servo-on (SON) OFF

The base circuit is shut off and the servo motor coasts.

2) Alarm occurrence

When an alarm occurs, the base circuit is shut off and the dynamic brake is operated to bring the servo motor to a sudden stop.

3) Emergency stop (EMG) OFF

The base circuit is shut off and the dynamic brake is operated to bring the servo motor to a sudden stop. Alarm ALE6 occurs.

4) Forward/reverse rotation stroke end (LSP/LSN) OFF

The servo motor is brought to a sudden stop and servo-locked.



### 3. POSITIONING SYSTEM

#### 3.4.3 Manual operation mode

For manual operation, set the operation mode selection signals (DI0, DI2) as listed below:

Operation Mode Selection Signal	ON/OFF
DI0	OFF
DI2	OFF

##### (1) Jog operation

Set the jog speed.

Parameter No.	Setting
8	0 to max. speed (r/min)

Turn on the signal (ST1, ST2) to start jog operation. At this time, the rotation direction is as indicated below. The acceleration/deceleration time constants used are those of speed block No. 1.

Start Signal	Parameter No. 2			
	□□0□	□□1□	□□2□	□□3□
ST1	CCW (address increase)	CW (address increase)	CCW (address decrease)	CW (address decrease)
ST2	CW (address decrease)	CCW (address decrease)	CW (address increase)	CCW (address increase)

The timing chart is as follows:

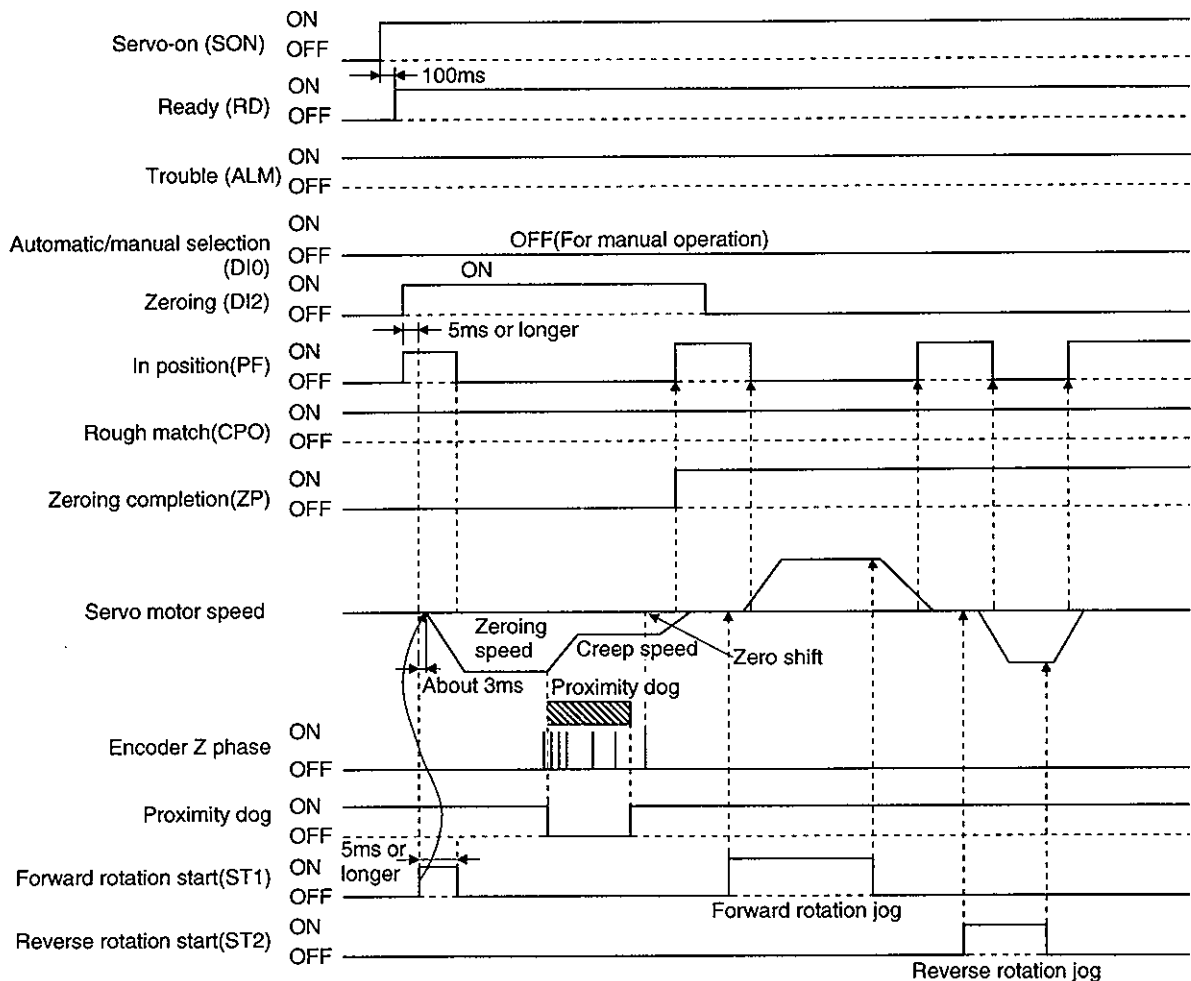

### 3. POSITIONING SYSTEM

#### (2) Manual pulse generator operation

##### (a) When option card (MR-H-D01) is not used

Set any of 1 to 3 in parameter No. 30 as indicated below to make operation from the manual pulse generator valid. Select the pulse multiplying factor of the manual pulse generator at this time.

Parameter No.30     0  
 \*Machine feedrate per revolution of manual pulse generator in metric system

Setting	Manual Pulse Generator	*Moving Distance/Number of Revolutions
0	Not used	
1	Used/pulse 1-time multiplication selected	100μm
2	Used/pulse 10-time multiplication selected	1mm
3	Used/pulse 100-time multiplication selected	10mm

Turn the manual pulse generator (MR-H-DP01) to rotate the servo motor. The turning direction of the manual pulse generator corresponds to the rotation direction of the servo motor as listed below:

Turning Direction of Manual Pulse Generator	Parameter No. 2			
	<input type="checkbox"/> <input type="checkbox"/> 0 <input type="checkbox"/>	<input type="checkbox"/> <input type="checkbox"/> 1 <input type="checkbox"/>	<input type="checkbox"/> <input type="checkbox"/> 2 <input type="checkbox"/>	<input type="checkbox"/> <input type="checkbox"/> 3 <input type="checkbox"/>
Forward rotation	CCW (address increase)	CW (address increase)	CCW (address decrease)	CW (address decrease)
Reverse rotation	CW (address decrease)	CCW (address decrease)	CW (address increase)	CCW (address increase)

Manual pulse generator

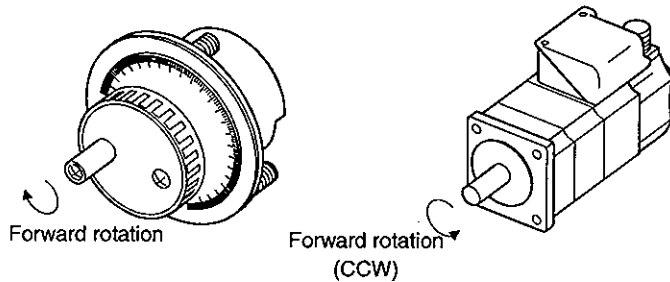

##### (b) When option card (MR-H-D01) is used

The pulse multiplying factor of the manual pulse generator can be changed by using pulse multiplying factor selection in parameter No. 65 and the pulse multiplying factor selection signals (DI20, DI21) of the MR-H-D01. Set any of 1 to 4 in parameter No. 65 as listed below to make operation from the manual pulse generator valid.

Parameter No. 65      
 \*Machine feedrate per revolution of manual pulse generator in metric system

Setting	Manual Pulse Generator	*Feed Distance/Number of Revolutions
0	Not used	
1	Used/pulse 1-time multiplication selected	100μm
2	Used/pulse 10-time multiplication selected	1mm
3	Used/pulse 100-time multiplication selected	10mm
4	Used/pulse multiplication selected externally	

Set  in parameter No. 65 to set the pulse multiplying factor externally. Relationships between the multiplying factors and pulse multiplying factor selection signals are listed below:

Multiplying Factor	Pulse Multiplying Factor Selection Signals	
	DI21	DI20
1 time	OFF	OFF
10 time	OFF	ON
100 time	ON	OFF

Turn the manual pulse generator to rotate the servo motor. The turning direction is as indicated in (2), (a) of this section.

### 3. POSITIONING SYSTEM

To erase the command remaining distance after a temporary stop, keep D10 on for 5ms or longer on the leading edge of PF after the temporary stop. Switching the automatic mode to the manual mode erases the remaining distance. To start positioning operation anew, switch on the start signal (ST1/ST2) after CPO has switched on.

The following timing chart shows operations performed after power-on and zeroing completion:

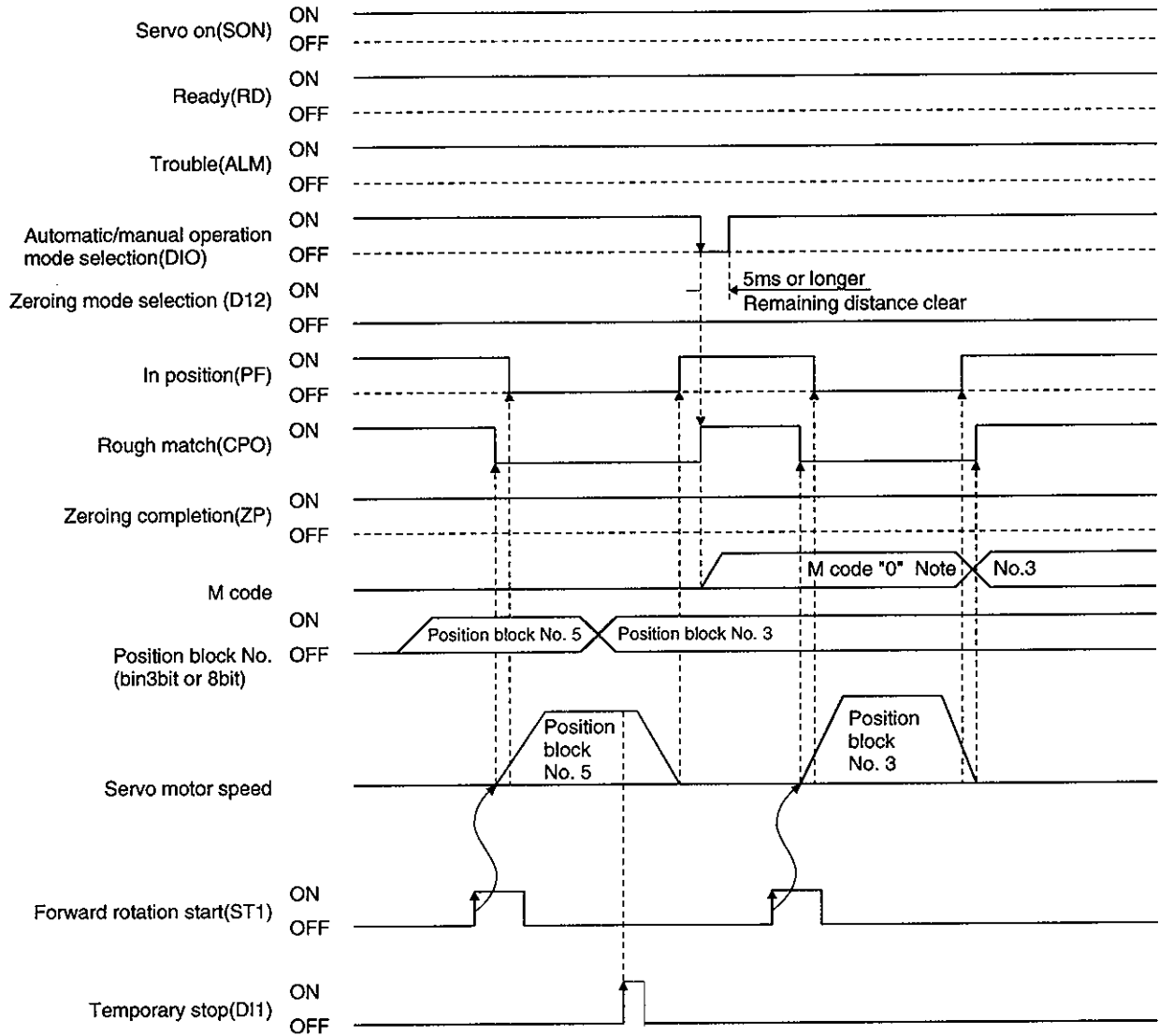

Note: Switching D10 off outputs "0".

### 3. POSITIONING SYSTEM

#### 3.4.4 Automatic operation mode

Set the operation mode select signals (DI0,DI2) as listed below.

Operation Mode Select Signal	ON/OFF
DI0	ON
DI2	OFF

#### (1) Positioning operation according to point table

##### (a) Setting of position block data

By setting parameter No.2, either absolute command positioning or incremental command positioning can be selected.

Parameter No.2

Set Value	Positioning Method
1	Incremental command positioning
2	Absolute command positioning

The number of position blocks that may be set is 8 (position block numbers 0 to 7) as standard, or 256 (position block numbers 0 to 255) when the option card (MR-H-D01) is used. Select it in parameter No.65.

Parameter No.65

Set Value	Number of Position Blocks
0	8 points standard
3	Option card is used

For absolute command positioning, set    2 in parameter No.2.

Using the parameter unit, set the position data (absolute value), M code and speed block number in the position block. (Refer to the next table.) For the position block setting method, refer to Section 3.5.1.

Position block No.	Position data (Absolute position)	M code	Speed Block No.
0	20000	1	1
1	-100	2	1
2	500	0	2
⋮	⋮	⋮	⋮
7(255)	12000	0	8

Item	Description
Position data	Target position to be reached
M code	Code 0 to 2 output during operation (0 to 99 when the MR-H-D01 is used)
Speed block No.	Speed block number 1 to 8 When speed block number 0 is set, the corresponding position block number is invalid.

### 3. POSITIONING SYSTEM

The unit ([mm], [inch]) and input range of the position data (absolute value) can be changed by setting parameter No. 4.

If positioning is performed with the setting made in excess of that input range, absolute position counter warning (ALE3) occurs. If power is switch off, then on in that status, the position cannot be restored properly.

Parameter No.4

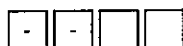

Set Value (STM)	Input Range(mm or inch)
0	-999.999 to +999.999
1	-9999.99 to +9999.99
2	-99999.9 to +99999.9
3	-999999 to +999999

Set Value	Unit
0	mm
1	inch

For the absolute position detection system, the setting range is as given in Expression 3.2

$$\text{Number of encoder pulses} \times 32767 \times \frac{\text{CDV}}{\text{CMX}} / 10^{\text{STM}} \dots\dots\dots (3.2)$$

- Number of encoder pulses : 8192P/rev or 16384P/rev
- CDV : Parameter No.6 (electronic gear)
- CMX : Parameter No.5 (electronic gear)
- STM : Lowest digit of parameter No.4 (travel magnification)

If the result of Expression 3.2 dose no fall within the range of STM, the input range is as set in STM (parameter No.4).

For incremental command positioning, set 1 in parameter No.2.

Using the parameter unit, set the position address (increment), M code and speed block number in the position block of the position data.

Position block No.	Position data (increment)	M code	Speed Block No.
0	20000	1	1
1	15000	2	1
2	500	0	2
⋮	⋮	⋮	⋮
7(255)	12000	0	8

Item	Description
Position data	Incremental value of servo motor
M code	Code 0 to 2 output during operation (0 to 99 when the MR-H-D01 is used)
Speed block No.	Speed block number 1 to 8 When speed block number 0 is set, the corresponding position block number is invalid.

### 3. POSITIONING SYSTEM

The unit ([mm], [inch]) and input range of the position data (increment) can be changed by setting parameter No.4

Parameter No.4

□ □ □ □

Set Value (STM)	Input Range(mm or inch)
0	0 to +999.999
1	0 to +9999.99
2	0 to +99999.9
3	0 to +999999

Set Value	Unit
0	mm
1	inch

#### (b) Setting of speed block data

By setting parameter No.3, either the linear or S-shaped acceleration/deceleration pattern can be selected. The number of speed blocks that may be set is 8 (speed block numbers 1 to 8).

Parameter No.3

□ □ □ □

Set Value	Acceleration/Deceleration Pattern
0	Linear acceleration/deceleration
1	S-shaped acceleration/deceleration

For linear acceleration/deceleration pattern, set □□□0 in parameter No.3.

Using the parameter unit, set the servo motor speed, acceleration time constant and deceleration time constant in the speed block. (Refer to the table on the right.)

Speed Block No.	Speed (r/min)	Acceleration Time Constant (ms)	Deceleration Time Constant (ms)
1	2000	220	20
2	500	100	50
3	1200	50	55
⋮	⋮	⋮	⋮
8	1500	20	30

For the speed block setting method, refer to Section 3.5.

Item	Description
Speed	0 to max. speed r/min
Acceleration/deceleration time constant	0 to 20000ms The acceleration and deceleration time constants set should be the lengths of time (ms) required for the servo motor to rise to and fall from the rated speed, respectively.

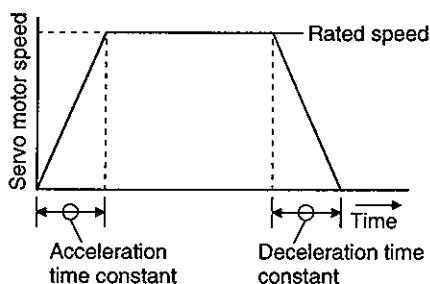

### 3. POSITIONING SYSTEM

For S-shaped acceleration/deceleration pattern, smooths the rise and fall of servo motor rotation. Set □□□1 in parameter No.3.

Using the parameter unit, set the servo motor speed, acceleration/deceleration time constant and S-shape time constant in the speed block. The acceleration time constant is equal to the deceleration time constant.

Speed Block No.	Speed (r/min)	Acceleration Deceleration Time Constant (ms)	S-Shape Time Constant (ms)
1	2000	1000	100
2	500	1500	200
3	1200	1200	100
⋮	⋮	⋮	⋮
8	1500	2000	200

Item	Description
Speed	0 to max. speed r/min
Acceleration/deceleration time constant	0 to 20000ms
S-shape time constant	100 to 450ms Set the S-shape time constant to 10-20% of the acceleration/deceleration time constant.

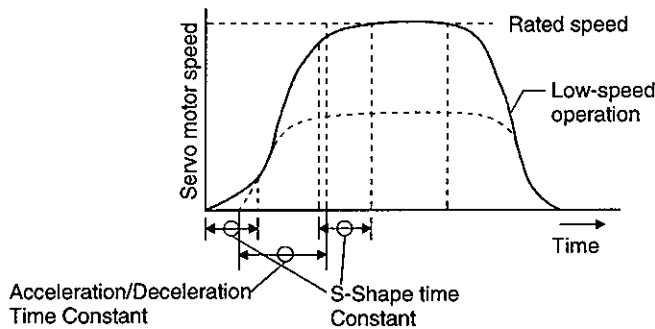

When the setting of each point table is complete, use the position block select signal (3-bit DEC, JFS, STP as standard) to select the position block number used for positioning. The relationship between the select signal and position block number is as listed below.

Standard (8 positions)

Position Block No.	STP	JFS	DEC
	bit2	bit1	bit0
0	0	0	0
1	0	0	1
2	0	1	0
⋮	⋮	⋮	⋮
7	1	1	1

3-bit binary 0: Any terminal-SG OFF 1: Any terminal-SG ON

MR-H-D01 used (256 positions)

Position Block No.	DI07	DI06	DI05	DI04	DI03	DI02	DI01	DI00
	bit7 (MSB)	bit6	bit5	bit4	bit3	bit2	bit1	bit0 (LSB)
0	0	0	0	0	0	0	0	0
1	0	0	0	0	0	0	0	1
2	0	0	0	0	0	0	1	0
⋮	⋮	⋮	⋮	⋮	⋮	⋮	⋮	⋮
255	1	1	1	1	1	1	1	1

8-bit binary 0: Any terminal-SG OFF 1: Any terminal-SG ON

### 3. POSITIONING SYSTEM

For absolute command positioning, switch the forward rotation start (ST1) on to rotate the servo motor to the present position. The rotation direction of the servo motor depends on the setting of parameter No.2. At this time, the reverse rotation start (ST2) is invalid.

Parameter No.2



Set Value	Servo Motor Rotation Direction
0	+ position data for CCW rotation - position data for CW rotation
1	+ position data for CW rotation - position data for CCW rotation

For incremental command positioning switch on the forward rotation start (ST1) or reverse rotation start (ST2) to rotate the servo motor to the present position. The rotation direction of the servo motor depends on the setting of parameter No.2. The relationship between the set value and servo motor rotation is as listed below.

Parameter No.2



Set Value	Servo Motor Rotation Direction	
	ST1:ON	ST2:ON
0	CCW rotation (Current value increase)	CW rotation (Current value decrease)
1	CW rotation (Current value increase)	CCW rotation (Current value decrease)
2	CCW rotation (Current value decrease)	CW rotation (Current value increase)
3	CW rotation (Current value decrease)	CW rotation (Current value increase)



### 3. POSITIONING SYSTEM

Shows operation performed after power on and zeroing completion.

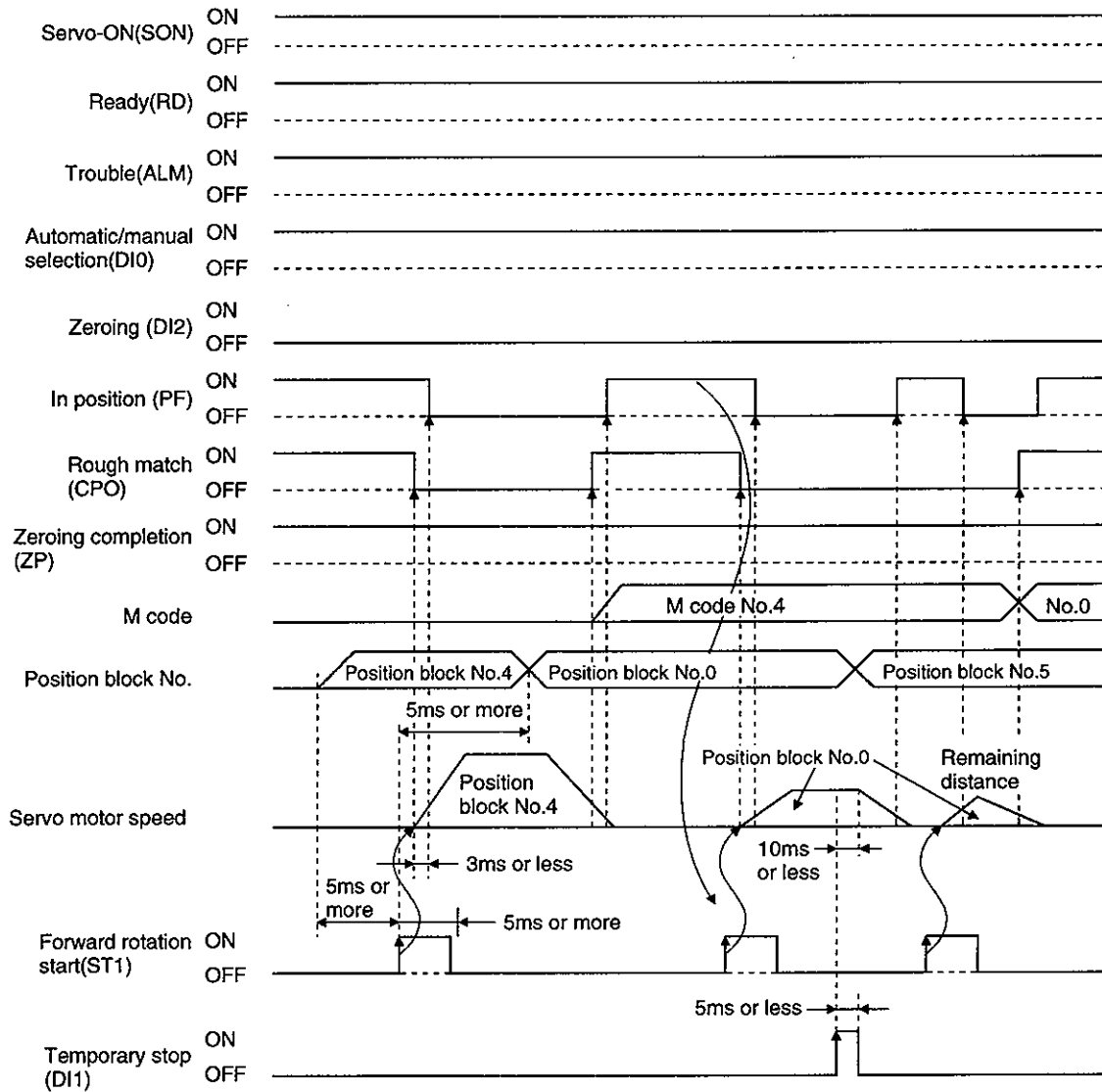

### 3. POSITIONING SYSTEM

#### (2) Positioning operation under digital switch position command

This operation requires the option card (MR-H-D01) and digital switch (MR-DS60). For wiring, refer to Section 3.2.3.

Set 1□11 in parameter No.65.

Parameter No.65

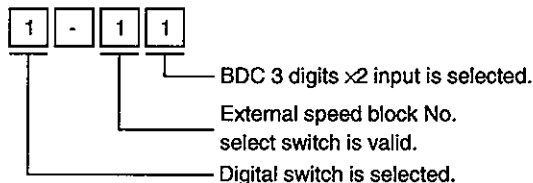

By setting parameter No.2, either absolute command positioning or incremental command positioning can be selected.

Parameter No.2

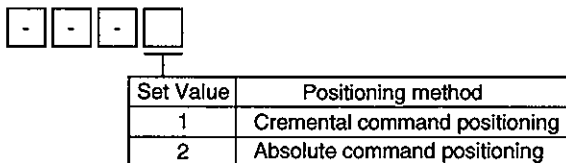

For absolute command positioning set □□□2 in parameter No.2.

Using the digital switch (MR-DS60), set the position data (absolute value). The unit ([mm],[inch]) and input range of the position data (absolute value) can be changed by setting parameter No.4.

Parameter No.4

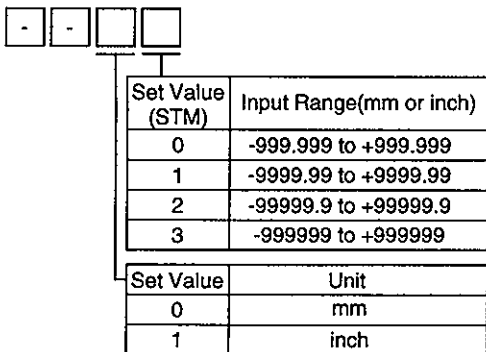

The input range of the absolute position detection system is as indicated in Section 3.4.4 (1).

### 3. POSITIONING SYSTEM

Use the speed select signal (3 bit, DI17, DI18, DI19) to select the speed block. The relationship between the speed select signal and speed block number is as listed on the below. Switch the forward rotation start (ST1) on to rotate the servo motor to the present position. The rotation direction of the servo motor depends on the setting of parameter No.2. Refer to (2), Section3.4.3.

8 speed selection

Speed Block No.	DI19	DI18	DI17
	bit2 (MSB)	bit1	bit0 (LSB)
1	0	0	0
2	0	0	1
3	0	1	0
⋮	⋮	⋮	⋮
8	1	1	1

3-bit binary      0: Any terminal-SG OFF      1: Any terminal-SG ON

Shows operation performed after power on and zeroing completion.

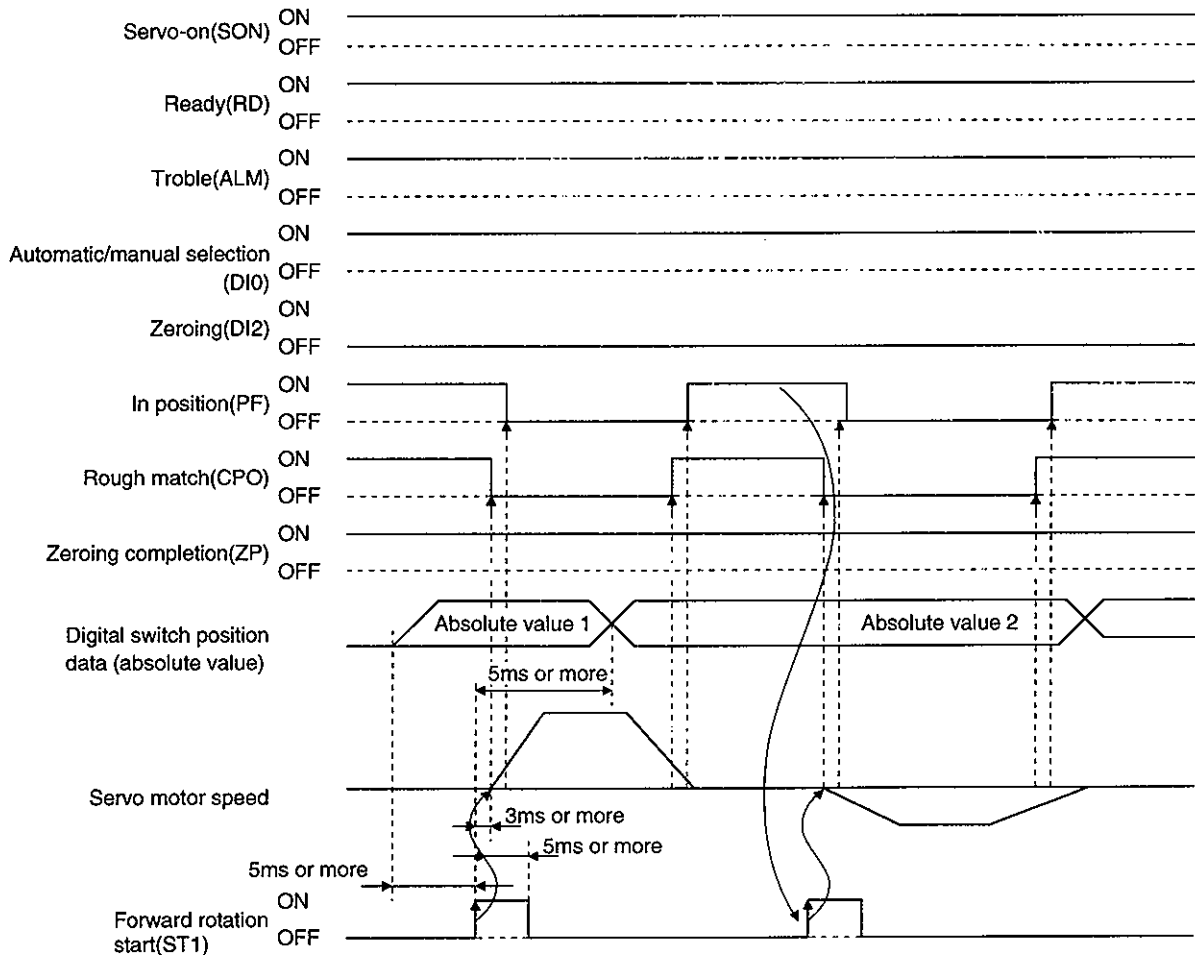

### 3. POSITIONING SYSTEM

For incremental command positioning, set  $\square\square\square 1$  in parameter No.2.

Using the digital switch (MR-DS60), set the position data (increment). The unit ([mm],[inch]) and input range of the position data (increment) can be changed by setting parameter No.4.

Parameter No.4



Set Value (STM)	Input Range(mm or inch)
0	0 to +999.999
1	0 to +9999.99
2	0 to +99999.9
3	0 to +999999

Set Value	Unit
0	mm
1	inch

Switch on the forward rotation start (ST1) or reverse rotation start (ST2) to rotate the servo motor to the preset position. Select the speed block as in the above-mentioned absolute command. The rotation direction of the servo motor depends on the setting of parameter No.2, as in the point table.

Shows operation performed after power on and zeroing completion.

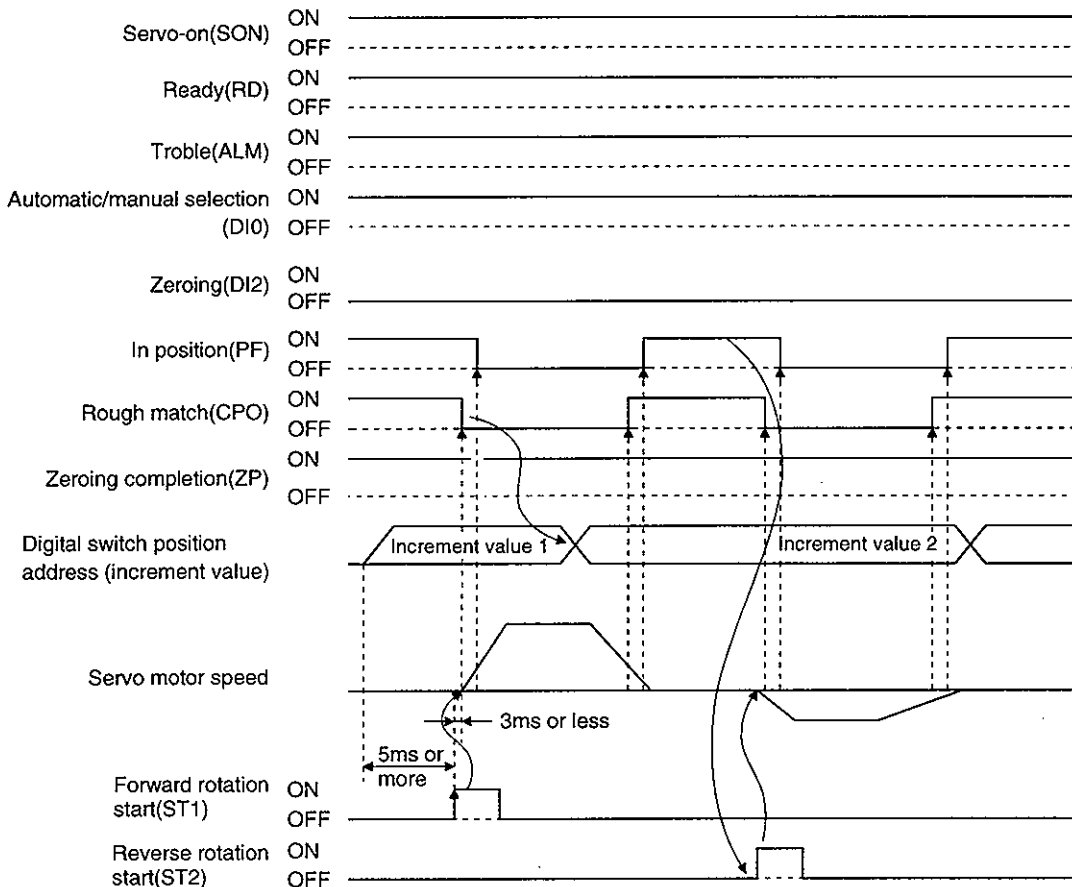

### 3. POSITIONING SYSTEM

---

(3) Positioning operation under programmable controller position command

This operation requires the option card (MR-H-D01). For wiring, refer to Section 3.2.4. The relationship between the position data and strobe signal is as in (13), Section 3.3.3.

By setting parameter No.2, either absolute command positioning or incremental command positioning can be selected.

Parameter No.2

□ - □ - □ □

Set Value	Positioning Method
1	Incremental command positioning
2	Absolute command positioning

For absolute command positioning, set □□□2 in parameter No.2.

Set 0□□1 in parameter No.65.

Select the input range and speed block number of the position data as in Section 3.4.4, (2).

Switch the forward rotation start (ST1) on to rotate the servo motor to the preset position. The rotation direction of the servo motor depends on the setting of parameter No.2. Refer to (2), Section 3.4.4.

### 3. POSITIONING SYSTEM

Shows operation performed after power on and zeroing completion.

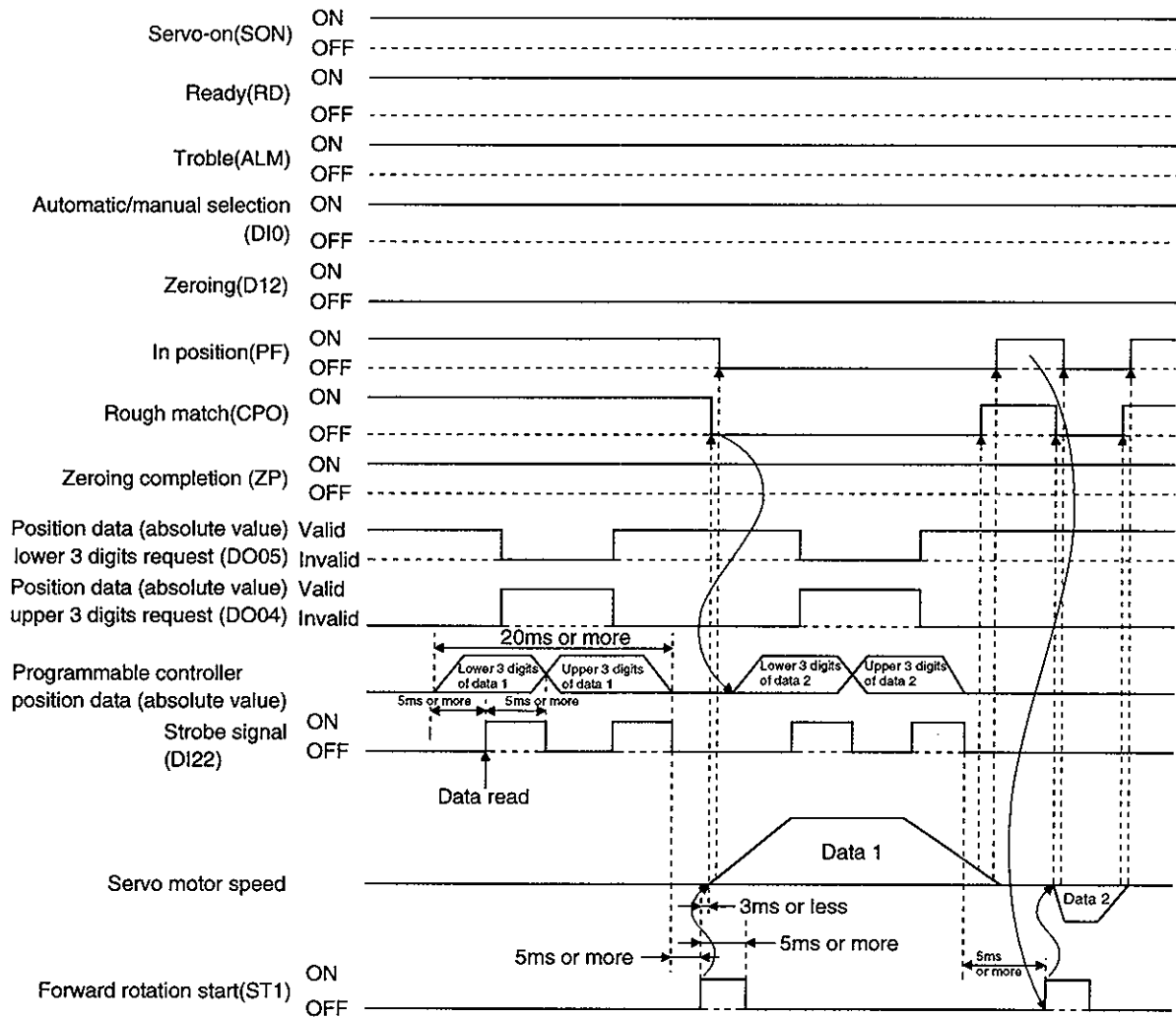

### 3. POSITIONING SYSTEM

For incremental command positioning set  $\square\square\square 1$  in parameter No.2.

Set  $0\square\square 1$  in parameter No.65.

The position data input range and speed block No. selection are as in Section 3.4.4 (2), (b).

Switch on the forward rotation start (ST1) or reverse rotation start (ST2) to rotate the servo motor to the present position. For the rotation direction of the servo motor, refer to (1), Section 3.4.4

Shows operation performed after power on and zeroing completion.

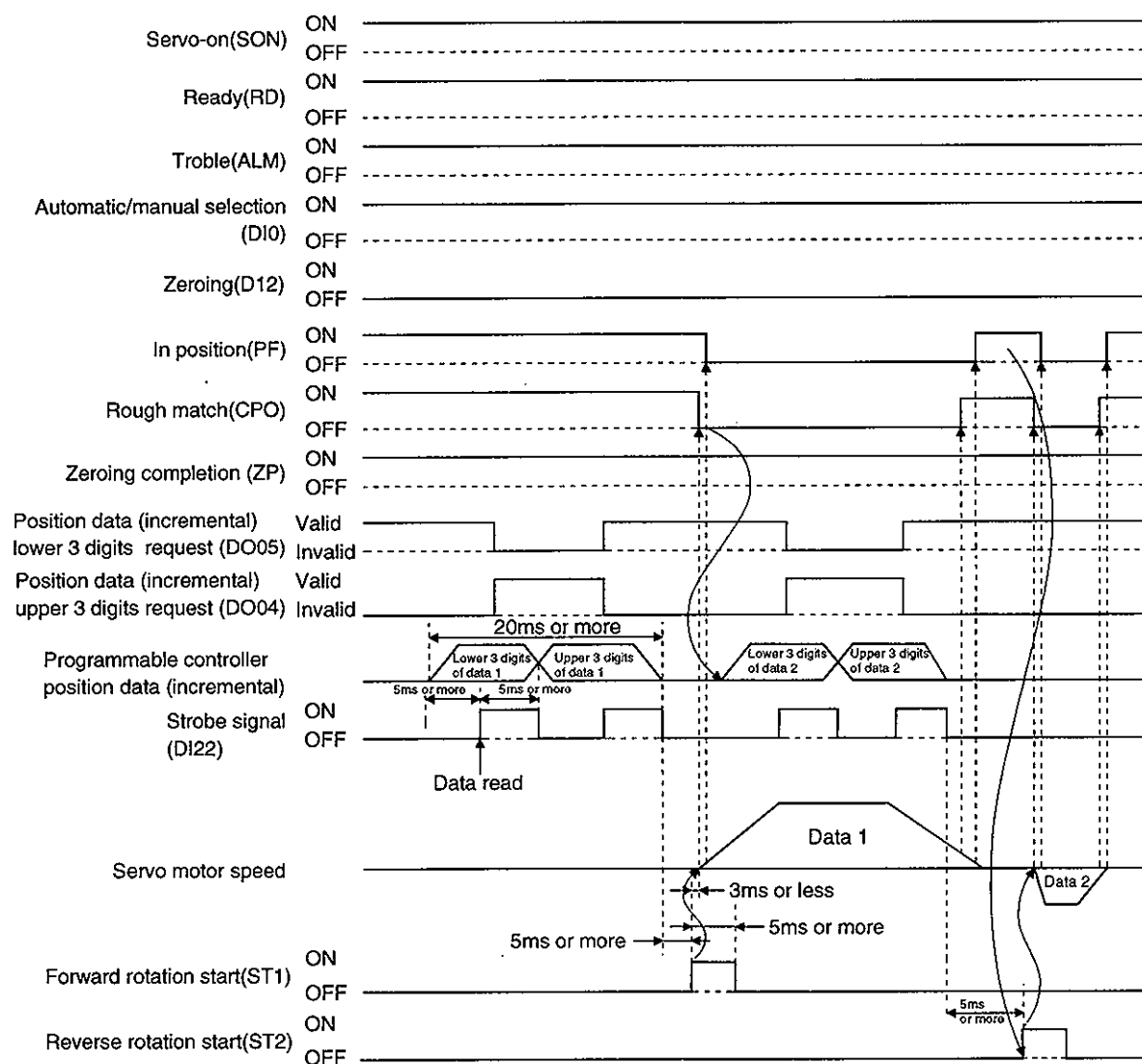

### 3. POSITIONING SYSTEM

#### 3.4.5 Manual zeroing mode

POINT
<ul style="list-style-type: none"> <li>When using the HA-MH, HA-FH, HA-SH, HA-LH or HA-UH series servo motor, always rotate the servo motor one or more revolutions before starting zeroing after power-on. You need not do this when using the HC-MF, HA-FF, HC-SF, HC-RF or HC-UF series servo motor.</li> </ul>

##### (1) Outline of zeroing

Zeroing is performed to match the command coordinates with the machine coordinates. In the incremental system, zeroing is required every time input power is switched on. In the absolute position detection system, once zeroing is done at the time of installation, the current position is retained if power is switched off. Hence, zeroing is not required when power is switched on again.

The MR-H-ACN has the zeroing methods given in this section. Choose the most appropriate method for your machine structure and application.

The MR-H-ACN has the automatic zeroing return function which executes zeroing by making an automatic return to a proper position if the machine has stopped beyond or at the proximity dog. Manual motion by jog operation or the like is not required.

##### (a) Manual zeroing types

Five manual zeroing types are available. Choose the optimum zeroing according to the machine type, etc.

Type	Zeroing Method	Features
Dog type zeroing	With deceleration started at the front end of a proximity dog, the position where the first Z-phase signal is given past the rear end of the dog or a motion has been made over the zero shift distance starting from the Z-phase signal is defined as a home position.	General zeroing method using a proximity dog. Repeatability of zeroing is excellent and the machine is less burdened. Used when the width of the proximity dog can be set greater than the deceleration distance of the servo motor.
Count type zeroing	With deceleration started at the front end of a proximity dog, the position where the first Z-phase signal is given after advancement over the preset moving distance after the proximity dog or a motion has been made over the zero shift distance starting from the Z-phase signal is defined as a home position.	Zeroing method using a proximity dog. Used when it is desired to minimize the length of the proximity dog.
Data setting type zeroing	The position reached after any automatic motion is defined as a home position.	No proximity dog required.
Stopper type zeroing	The position where the machine stops when its part is pressed against a machine stopper is defined as a home position.	Since the machine part collides with the machine stopper, zeroing speed must be set to a fully low value and the machine and stopper strength must be fully considered.

Note: The Z-phase signal is a pulse generated once per servo motor revolution. It can be output as the encoder Z-phase output signal (OP).



### 3. POSITIONING SYSTEM

---

(b) Zeroing parameter

When performing zeroing, set parameter No.9 as follows:

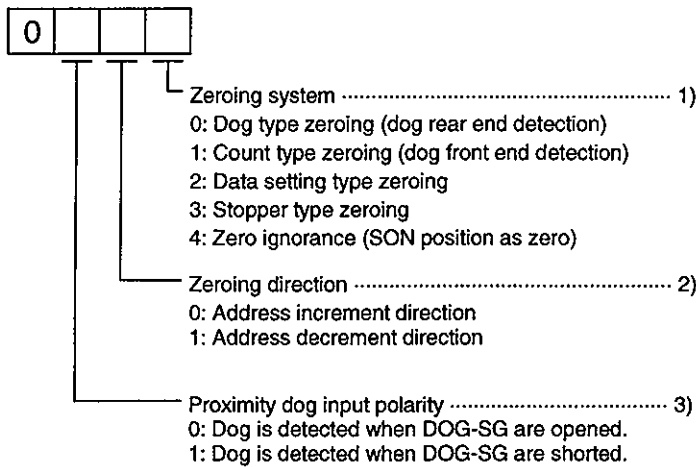

- 1) Choose the zeroing method.
- 2) Choose the starting direction of zeroing. Set "0" to start zeroing in the direction in which the address is incremented from the current position, or "1" to start zeroing in the direction in which the address is decremented.
- 3) Choose the polarity at which the proximity dog is detected. Set "0" to detect the dog when the proximity dog device (across DOG-SG) is opened, or "1" to detect the dog when the device is shorted.

(c) Instructions

- 1) Before starting zeroing, always make sure that the limit switch operates.
- 2) Confirm the zeroing direction. Incorrect setting will cause the machine to run reversely.
- 3) Confirm the proximity dog input polarity. Otherwise, misoperation can occur.

### 3. POSITIONING SYSTEM

(2) Dog type zeroing

A zeroing method using a proximity dog.

With deceleration started at the front end of the proximity dog, the position where the first Z-phase signal is given past the rear end of the dog or a motion has been made over the zero shift distance starting from the Z-phase signal is defined as a home position.

(a) Signals, parameters

Set the input signals and parameters as follows:

Item	Device/Parameter Used	Description
Manual zeroing mode selection	Automatic/manual selection signal (DI0)	Open DI0-SG (OFF).
	Zeroing (DI2)	Short DI2-SG (ON).
Dog type zeroing	Parameter No.9	<input type="checkbox"/> <input type="checkbox"/> <input type="checkbox"/> 0: Dog type zeroing is selected.
Zeroing direction	Parameter No.9	Refer to (1) (b) in this section and choose zeroing direction.
Dog input polarity	Parameter No.9	Refer to (1) (b) in this section and choose dog input polarity.
Zeroing speed	Parameter No.11	Set speed until detection of dog.
Creep speed	Parameter No.12	Set speed after detection of dog.
Zero shift distance	Parameter No.13	Set when shifting the home position starting at the first Z-phase signal after passage of proximity dog rear end.
Zeroing acceleration/deceleration time constants	Speed block No.1	Use the acceleration/deceleration time constants of speed block No.1.
Zeroing position data	Parameter No.10	Address reached by zeroing is stored automatically.

(b) Length of proximity dog

To ensure that the Z-phase signal of the servo motor is generated during detection of the dog signal, the proximity dog should have the length which satisfies formulas (3.2) and (3.3):

$$L1 \geq \frac{V}{60} \cdot \frac{td}{2} \dots\dots\dots (3.2)$$

L1 : Proximity dog length [mm]

V : Zeroing speed [mm/min]

td : Deceleration time [s]

$$L2=2 \cdot \Delta S \dots\dots\dots (3.3)$$

L2 : Proximity dog length [mm]

ΔS : Moving distance per servo motor revolution [mm]

### 3. POSITIONING SYSTEM

#### (c) Timing chart

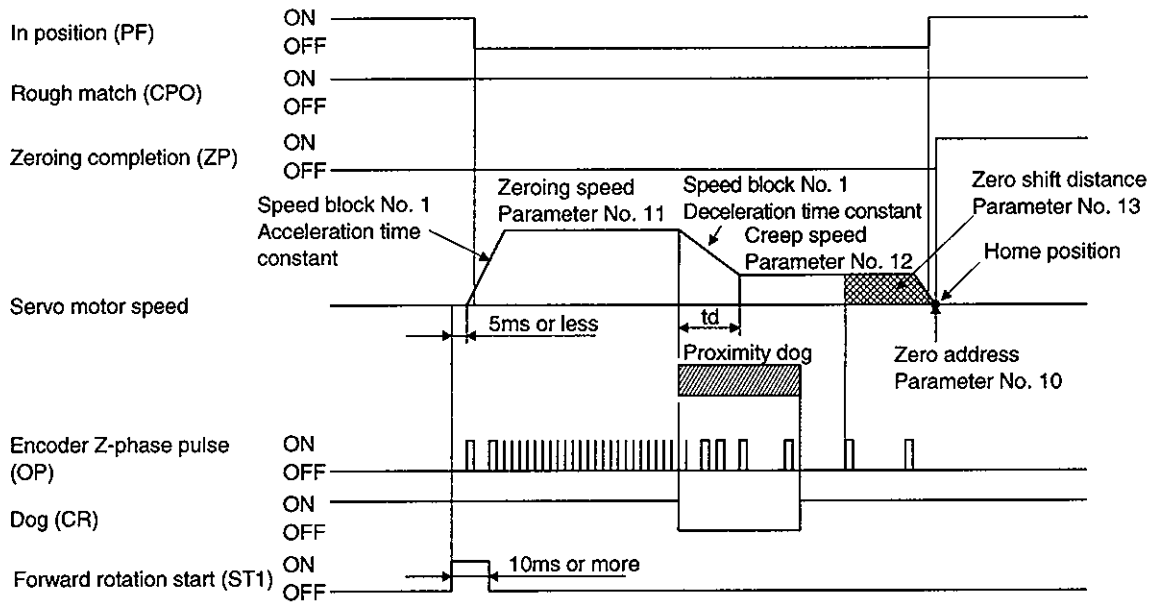

The address on completion of zeroing is the value automatically set in parameter No.10 (zeroing position data).

#### (d) Adjustment

In dog type zeroing, adjust to ensure that the Z-phase signal is generated during dog detection. Locate the rear end of the proximity dog at approximately the center of two consecutive Z-phase signals.

The position where the Z-phase signal is generated can be monitored in "Within one-revolution position" of "Status display".

Servo motor	Within one-revolution position		
HC-MF· HA-FF· HC-UF 3000 r/min	0	4096	0
HC-SF· RF· UF 2000 r/min	0	8192	0

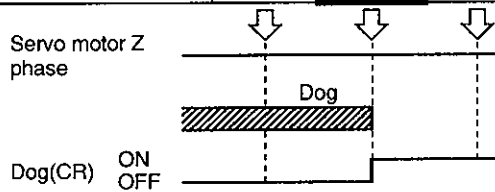

### 3. POSITIONING SYSTEM

#### (3) Count type zeroing

In count type zeroing, a motion is made over the distance set in parameter No.14 (moving distance after proximity dog) after detection of the proximity dog front end. The position where the first Z-phase signal is given after that is defined as a home position. Hence, if the dog signal (CR) is 10ms or longer, there is no restriction on the dog length. This zeroing method is used when the required proximity dog length cannot be reserved to use dog type zeroing or when the dog signal is entered electrically from a controller or the like.

#### (a) Signals, parameters

Set the input signals and parameters as follows:

Item	Device/Parameter Used	Description
Manual zeroing mode selection	Automatic/manual selection signal (DI0)	Open DI0-SG (OFF).
	Zeroing (DI2)	Short DI2-SG (ON).
Count type zeroing	Parameter No.9	$\square\square\square 1$ : Count type zeroing is selected.
Zeroing direction	Parameter No.9	Refer to (1) (b) in this section and choose zeroing direction.
Dog input polarity	Parameter No.9	Refer to (1) (b) in this section and choose dog input polarity.
Zeroing speed	Parameter No.11	Set speed until detection of dog.
Creep speed	Parameter No.12	Set speed after detection of dog.
Zero shift distance	Parameter No.13	Set when shifting the home position, starting at the first Z-phase signal given after passage of the proximity dog front end and movement over the moving distance.
Moving distance after proximity dog	Parameter No.14	Set the moving distance after passage of proximity dog front end.
Zeroing acceleration/deceleration time constants	Speed block No.1	Use the acceleration/deceleration time constants of speed block No.1.
Zeroing position data	Parameter No.10	Address reached by zeroing is stored automatically.

#### (b) Timing chart

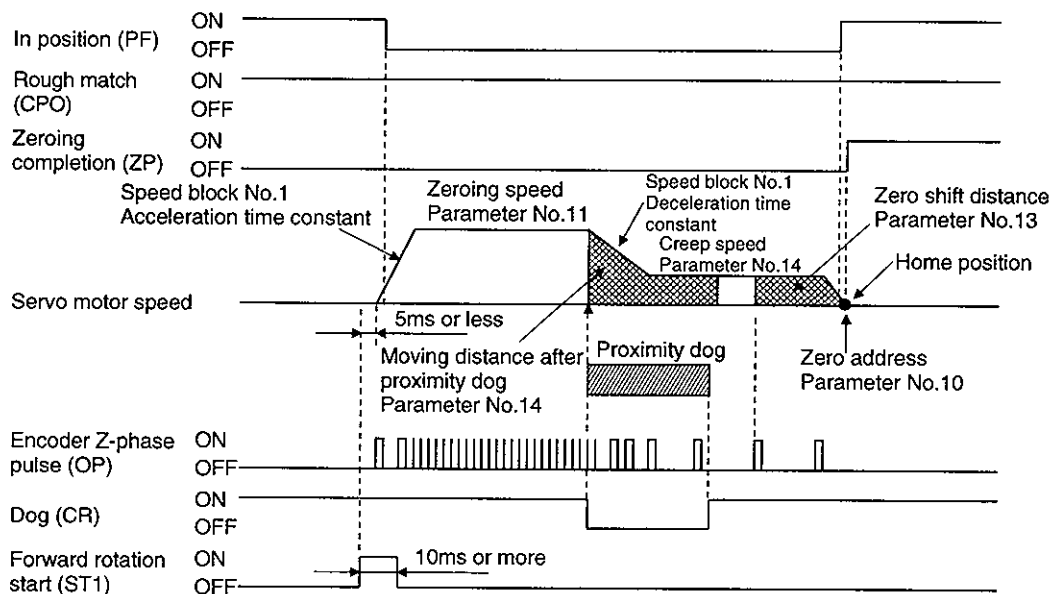

The address on completion of zeroing is the value automatically set in parameter No.10 (zeroing position data).

### 3. POSITIONING SYSTEM

#### (4) Data setting type zeroing

In data setting type zeroing, a motion is made to any position by jog operation, manual pulse generator operation or the like to make a home position return, and the position reached is defined as a home position.

##### (a) Signals, parameters

Set the input signals and parameters as follows:

Item	Device/Parameter Used	Description
Manual zeroing mode selection	Automatic/manual selection signal (DI0)	Open DI0-SG (OFF).
	Zeroing (DI2)	Short DI2-SG (ON).
Data setting type zeroing	Parameter No.9	□□□2: Data setting type zeroing is selected.
Zeroing position data	Parameter No.10	Address reached by zeroing is stored automatically.

##### (b) Timing chart

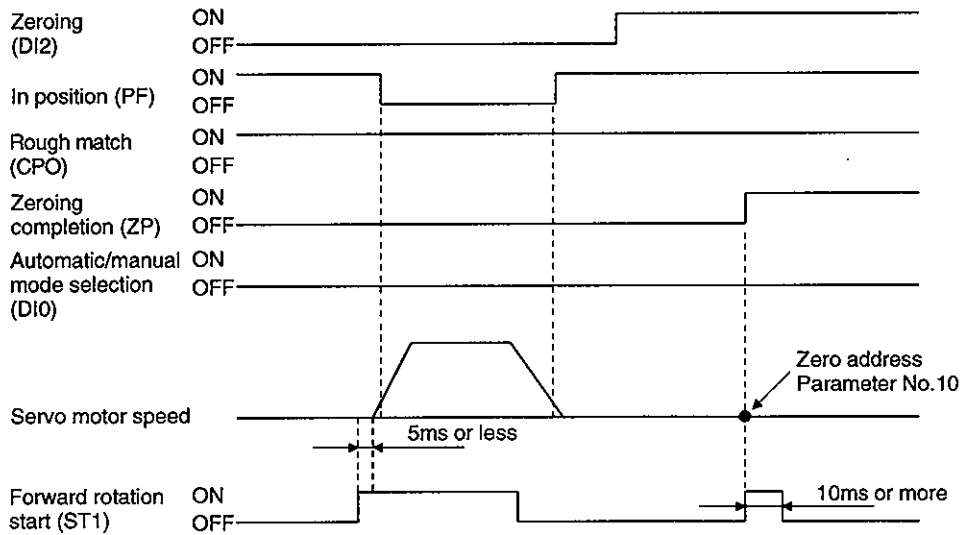

The address on completion of zeroing is the value automatically set in parameter No.10 (zeroing position data).

### 3. POSITIONING SYSTEM

#### (5) Stopper type zeroing

In stopper type zeroing, a machine part is pressed against a stopper or the like by jog operation, manual pulse generator operation or the like to make a home position return and that position is defined as a home position.

#### (a) Signals, parameters

Set the input signals and parameters as follows:

Item	Device/Parameter Used	Description
Manual zeroing mode selection	Automatic/manual selection signal (DI0)	Open DI0-SG (OFF).
	Zeroing (DI2)	Short DI2-SG (ON).
Stopper type zeroing	Parameter No.9	□□□3: Stopper type zeroing is selected.
Zeroing position data	Parameter No.10	Address reached by zeroing is stored automatically.

#### (b) Timing chart

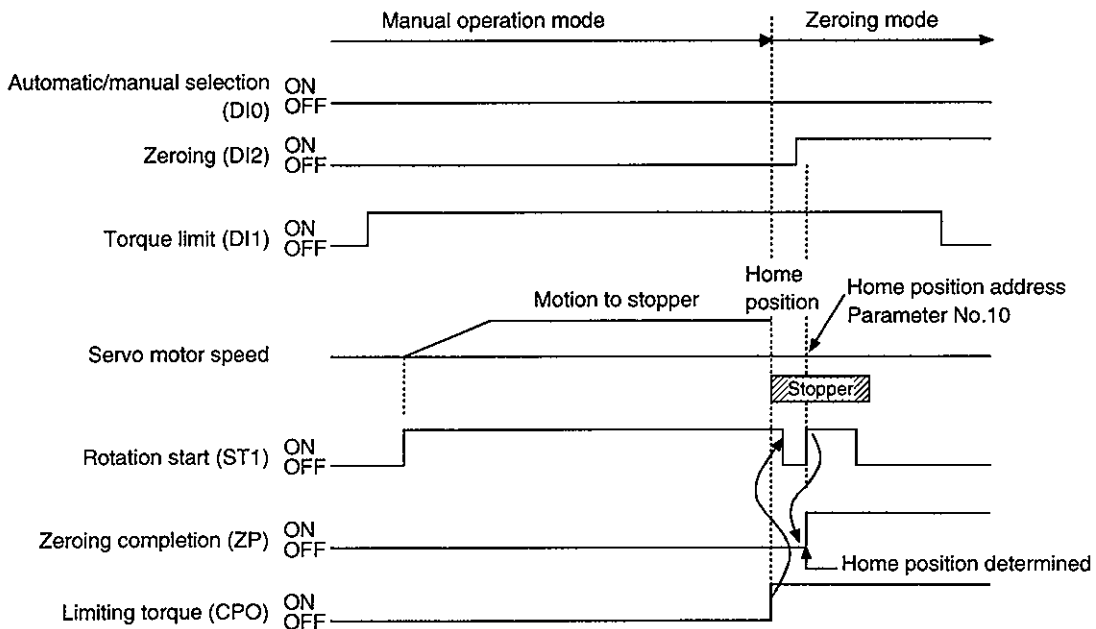

The address on completion of zeroing is the value automatically set in parameter No.10 (zeroing position data).

### 3. POSITIONING SYSTEM

---

#### (6) Automatic zeroing return function

If the current position is at or beyond the proximity dog in dog or count type zeroing, you need not make a start after making a return by jog operation or the like.

When the current position is at the proximity dog, an automatic return is made before zeroing.

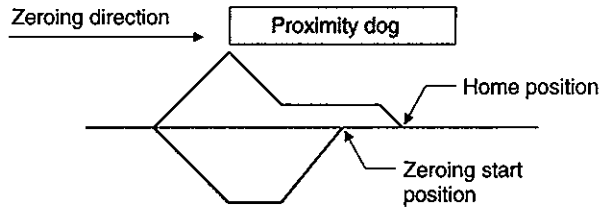

At a start, a motion is made in the zeroing direction and an automatic return is made on detection of the limit switch. The motion stops past the front end of the proximity dog, and zeroing is resumed at that position. If the proximity dog cannot be detected, the motion stops on detection of the opposite limit switch and AL 90 occurs.

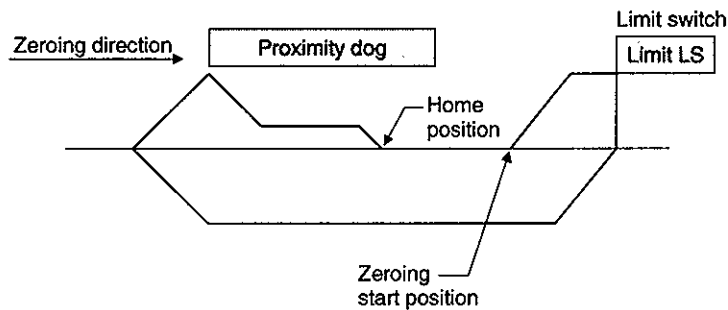

### 3. POSITIONING SYSTEM

#### 3.4.6 Automatic zeroing

To define a home position (parameter No.10) by manual zeroing after power-on and then return to the home position, use of automatic zeroing enables an automatic return to the home position at high speed. In an absolute position system, manual zeroing is not required after power-on. Also, a second home position can be set in parameter No.15.

After power-on, execute manual zeroing in advance.

Set the operation mode selection signals (DI0, DI2) as indicated below:

Operation Mode Select Signal	ON/OFF
DI0	ON
DI2	ON

Use parameter No.11 to set the zeroing speed for automatic zeroing. Use the data of speed block No.1 in the point table to set the acceleration and deceleration time constants. Switching the forward rotation signal (ST1) on starts a high-speed automatic return to the home position.

Parameter No.	Description	Setting Range
11	Zeroing speed	0 to max. speed (r/min)

A second home position can be set and an automatic return to that position performed.

Set the position address of the second home position in parameter No. 15. Switch the reverse rotation start signal (ST2) on to start a high-speed automatic return to the second home position.

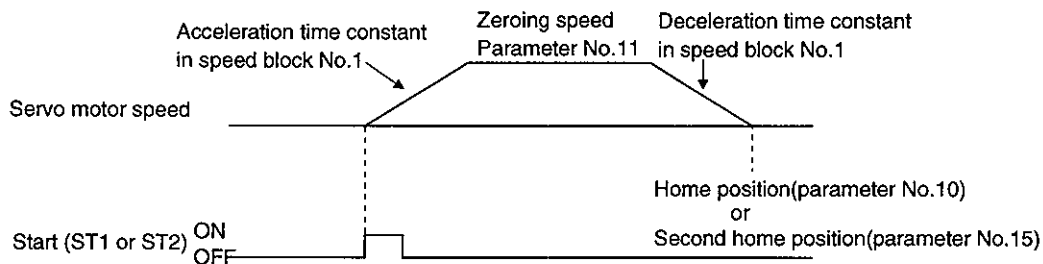



### 3. POSITIONING SYSTEM

#### 3.5 Absolute position detection system

An absolute position detection system can be configured up by merely loading an absolute position data back-up battery and setting parameter values.

You only have to make home position setting once and need not perform zeroing at every power-on.

##### (1) Restrictions

An absolute position detection system cannot be built under the following conditions:

- 1) Stroke-less coordinate system, e.g. rotary shaft, infinite positioning.
- 2) Operation performed in incremental value command type positioning system.

##### (2) Specifications

Item	Description
System	Electronic battery backup system
Battery	1 piece of lithium battery ( primary battery, nominal + 3.6V) Type: MR-BAT or A6BAT
Maximum revolution range	Home position $\pm 32767$ rev.
(Note 1) Maximum speed at power failure	500r/min
(Note 2) Battery backup time	Approx. 10,000 hours (battery life with power off)
(Note 3) Data holding time during battery replacement	2 hours at delivery, 1 hour in 5 years after delivery
Battery storage period	5 years from date of manufacture

Note: 1. Maximum speed available when the shaft is rotated by external force at the time of power failure or the like.

2. Time to hold data by a battery with power off.

3. Period during which data can be held by the super capacitor in the encoder after power-off, with the battery voltage low or the battery removed, or during which data can be held with the encoder cable disconnected.

Battery replacement should be finished within this period.

##### (3) Structure

Component	Description	
Controller	Use standard models.	
Servo motor	HA-LH	Use a servo motor equipped with absolute position encoder (-Y).
	HC-MF · HA-FF	Use standard models.
	HC-SF · HC-RF	
	HC-UF	
Battery	MR-BAT or A6BAT	
Encoder cable	Use a standard model. When fabricating, refer to, Section 15.1.6	

### 3. POSITIONING SYSTEM

#### (4) Outline of absolute position detection data communication

For normal operation, as shown below, the encoder consists of a detector designed to detect a position within one revolution and a cumulative revolution counter designed to detect the number of revolutions.

The absolute position detection system always detects the absolute position of the machine and keeps it battery-backed, independently of whether the general-purpose programming controller power is on or off. Therefore, once the home position is defined at the time of machine installation, zeroing is not needed when power is switched on thereafter.

If a power failure or a fault occurs, restoration is easy.

Also, the absolute position data, which is battery-backed by the super capacitor in the encoder, can be retained within the specified period (cumulative revolution counter value retaining time) if the cable is unplugged or broken.

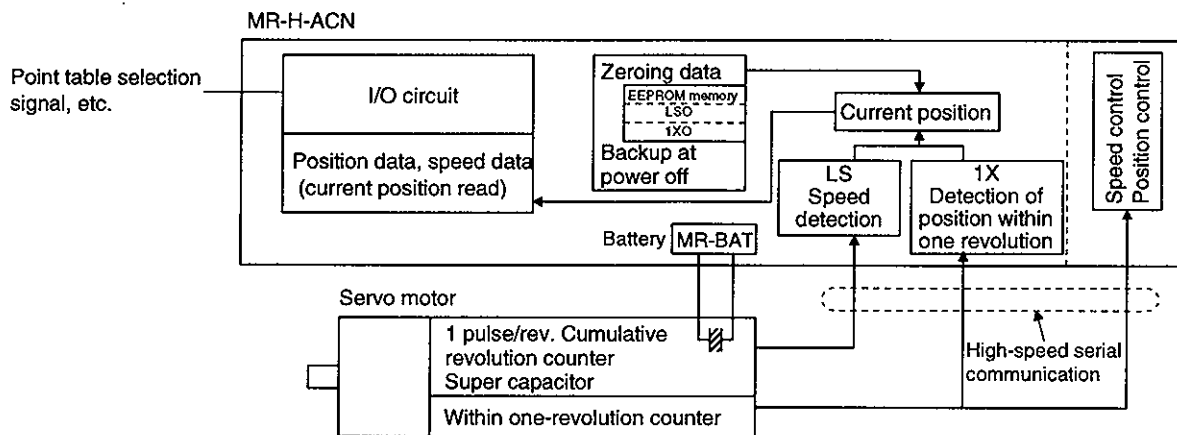

#### (5) Battery installation procedure



#### WARNING

- Before starting battery installation on procedure, make sure that the charge lamp is off more than 10 minutes after power-off. Then confirm that voltage safe in the tester or the like. Otherwise, you may get an electric shock.

#### POINT

The internal circuits of the controller may be damaged by static electricity. Always take the following precautions:

- Ground human body and work bench.
- Do not touch the conductive areas, such as connector pins and electrical parts, directly by hand.

- 1) Open the terminal block cover and switch window. (When the model used is the MR-H500ACN or more, also remove the front panel.)
- 2) Install the battery in the battery holder.
- 3) Install the battery connector into CN5 unit it clicks.

### 3. POSITIONING SYSTEM

(a) MR-H10ACN to MR-H350ACN

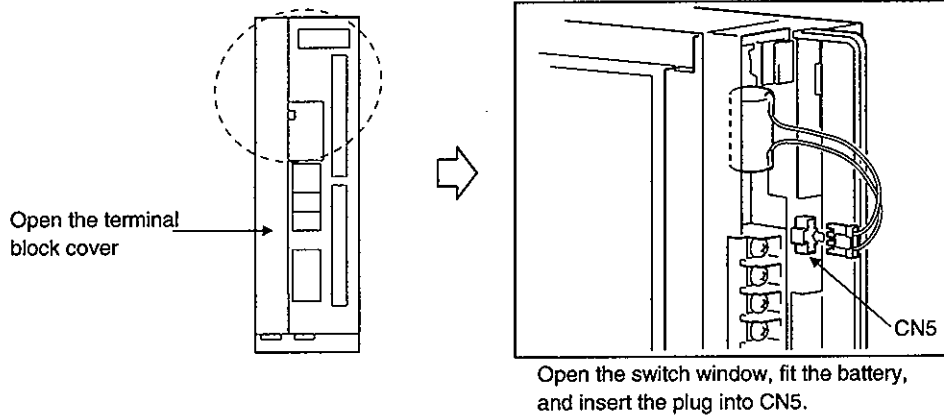

(b) MR-H500ACN,MR-H700ACN

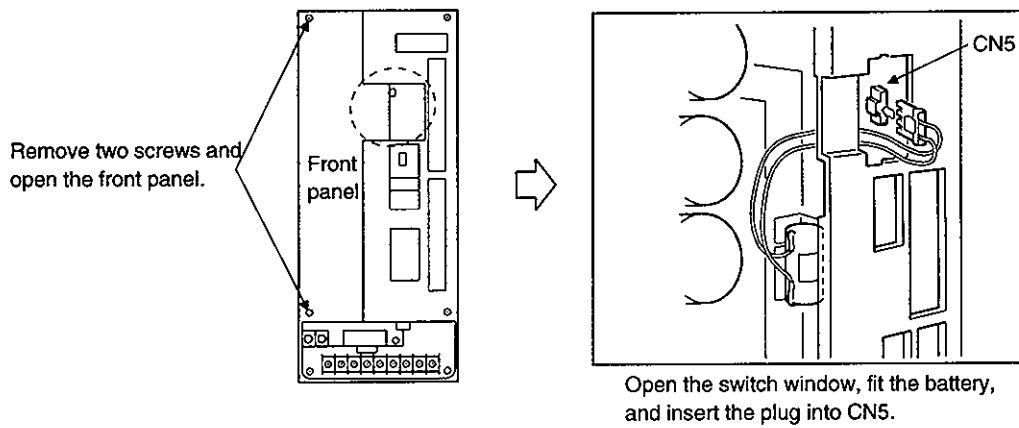

(c) MR-H11KACN to MR-H22KACN

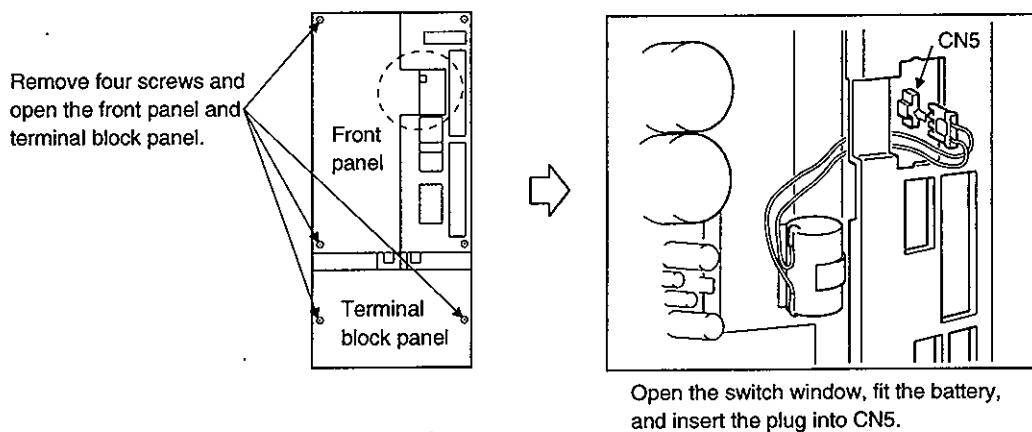

### 3. POSITIONING SYSTEM

---

(6) Parameter setting

Set parameter No. 3 as indicated below to make the absolute position detection system valid.

Parameter No.3

1	-	-	-
---	---	---	---

Selection of absolute position detection system

0: Incremental system

1: Absolute position detection system

### 3. POSITIONING SYSTEM

#### 3.6 Point Table Data Setting Procedures

##### (1) Position block data

##### (a) Position block data input

Step	Parameter Unit Operation	Parameter Unit Screen
1)	Press [PARAM/DATA] (call the data setting mode screen). Press [▲]/[▼] to select the block to be set (select the position block). Press [↵] to define the block to be set (select the position block).	<pre> &lt;Set mode&gt; ▲ → Pos. Block Speed Block Edit :HELP ▼                     </pre>
2)	Press [B8] and [B5] on the ten-key pad to specify the position block number to be set (for 85). Press [↵] to define the position block number to be set.	<pre> &lt;Pos. set&gt; Block No.       85 Read:↵                     </pre>
3)	Press [▲]/[▼] to specify the position block number to be set (for 85). Press [↵] to define the position block number to be set.	<pre> 85 → 12345.0 ▲ 86  78901.2 87  34567.8 88  90123.4 ▼                     </pre>
4)	On the data list screen, press [▲]/[▼] to select the data field into which data is to be input (select the position). Press [↵] to define the data field into which data is to be input (define the position).	<pre> 85 Pos. Bloc ▲ → Pos 12345.6 M Code 68 Speed No 5 ▼                     </pre>
5)	On the input screen, press [D7], [B8], [1STEP•] and [F9] on the ten-key pad to enter position data (for 78.9). Press [↵] to write the position data and press [CAN] to proceed to step 6).	<pre> 85 Position ▲ 12345.6       78.9 Write:↵ mm ▼                     </pre>
6)	On the data list screen, press [▲]/[▼] to select the data field into which data is to be input (select the M code). Press [↵] to define the data field into which data is to be input (define the M code).	<pre> 85 Pos. Bloc ▲ Pos 78.9 → M code 68 Speed No 5 ▼                     </pre>
7)	On the input screen, press [B5] and [0] on the ten-key pad to enter the M code (for 50). Press [↵] to write the M code and press [CAN] to proceed to step 8).	<pre> 85 M code ▲       68       50 Write:↵ ▼                     </pre>
8)	On the data list screen, press [▲]/[▼] to select the data field into which data is to be input (select the speed number). Press [↵] to define the data field into which data is to be input (define the speed number).	<pre> 85 Pos. Bloc ▲ Pos 78.9 M code 50 → Speed No 5 ▼                     </pre>
9)	On the input screen, press [2] on the ten-key pad to enter the speed number (for 2). Press [↵] to write the speed number. <b>Position block input complete</b> Press [CAN] twice to return to step 6).	<pre> 85 Speed No ▲       5       2 Write:↵ ▼                     </pre>
10)	If the key pressed is wrong, press [STOP/RESET] to return to the input screen, or press [CAN] to return to the data list screen.	<pre> 85 Speed No ▲       5       9 Error:RST ▼                     </pre>

### 3. POSITIONING SYSTEM

(b) Speed block reference

The speed block settings can be referred to during position block input, but cannot be input.

Step	Parameter Unit Operation	Parameter Unit Screen
1)	<p>On the position block screen</p> <p>Press [SHIFT] and [3] to move to the speed block reference screen.</p> <p>Press [▲]/[▼] to select the block to be set (select the position block).</p>	<pre> 5 Speed Block ▲ Speed 2000.0 Acc 20000 Dec 20000 ▼                     </pre>
2)	<p>Press [CAN] to move to the position block data input selection screen.</p>	<pre> 85 Pos. Bloc ▲ → Pos 12345.6 M code 68 Speed No 5 ▼                     </pre>

### 3. POSITIONING SYSTEM

(c) Teaching

Teaching can be used for absolute command positioning.

Switch the automatic/manual operation mode signal (DI0) off and the zeroing signal (DI2) off to select the manual operation mode, and use the parameter unit to perform teaching in the following procedure:

Step	Parameter Unit Operation	Parameter Unit Screen
1)	Press [PARAM/DATA] (call the data setting mode screen). Press [▲]/[▼] to select the position block. Press [↵] to define the position block.	<pre> &lt;Set mode&gt; ▲ →Pos. Block Speed Block Edit :HELP ▼                     </pre>
2)	Press [ <sup>E</sup> 8] and [ <sup>B</sup> 5] on the ten-key pad to specify the position block number to be set (for 85). Press [↵] to define the position block number to be set.	<pre> &lt;Pos. set&gt; Block No.      85 Read:↵                     </pre>
3)	If the key pressed is wrong, press [STOP/RESET] to return to step 2).	<pre> &lt;Pos. set&gt; Block No.      300 Error:RST                     </pre>
4)	Press [▲]/[▼] to specify the position block number to be set (for 85). Press [↵] to define the position block number to be set.	<pre> 85 → 12345.0 ▲ 86   78901.2 87   34567.8 88   90123.4 ▼                     </pre>
5)	Press [SHIFT] and [1] to switch to the teaching screen. Press [▲]/[▼] to select the position block number in which teaching is to be performed.	<pre> 85 Teach ▲ Pos 12345.6 ( 1000.0 ) Write:↵ mm ▼                     </pre>
6)	<b>Manual operation</b> By jogging (use ST1, ST2) or using the manual pulse generator, move the machine to the target position. Press [↵] to define the position data to be set (define 8570.0). Write complete Press [SHIFT] and [3] to return to step 5).	<pre> 85 Teach ▲ Pos 12345.6 ( 8570.0 ) Write:↵ mm ▼                     </pre>
7)	If the key pressed is wrong, press [STOP/RESET] to return to step 6).	<pre> 85 Teach ▲ Pos 8570.0 ( -305.3 ) Pr02 Mis.Set ▼  85 Teach ▲ Pos 8570.0 ( 1.8 ) OT Er.:RST ▼                     </pre>

### 3. POSITIONING SYSTEM

#### (2) Speed block data input

Step	Parameter Unit Operation	Parameter Unit Screen
1)	Press [PARAM/DATA] (call the data setting screen). Press [▲]/[▼] to select the block to be set (select the speed block). Press [↵] to define the block to be set.	<pre> &lt;Set mode&gt; ▲ Pos. Block →Speed Block Edit :HELP ▼                     </pre>
2)	Press [ <sup>B</sup> 5] on the ten-key pad to specify the speed block number to be set (for 5). Press [↵] to define the speed block number to be set.	<pre> &lt;Speed set&gt; Block No.      5 Read: ←                     </pre>
3)	If the key pressed is wrong, press [STOP/RESET] to return to step 2).	<pre> &lt;Speed set&gt; Block No.      9 Error:RST                     </pre>
4)	Press [▲]/[▼] to specify the speed block number to be set (for 5). Press [↵] to define the speed block number to be set.	<pre> &lt;Speed set&gt; ▲ 5 → 2000.0 6  1000.0 7  3000.0 ▼                     </pre>
5)	On the data list screen, press [▲]/[▼] to select the data field into which data is to be input ( select the speed). Press [↵] to define the data field into which data is to be input (define the speed).	<pre> 5 SpeedBlock ▲ →Speed  2000.0 Acc     10000 Dec     10000 ▼                     </pre>
6)	On the input screen, press [3] [0] [0] [0] on the ten-key pad to enter the speed (for 3000r/min). Press [↵] to write the speed and press [CAN] to proceed to step 7).	<pre> 5 Ref.Speed ▲ 2000.0 3000.0 Write: ← r/min ▼                     </pre>
7)	On the data list screen, press [▲]/[▼] to select the data field into which data is to be input (select the acceleration time constant). Press [↵] to define the data field into which data is to be input (define the acceleration time constant).	<pre> 5 SpeedBlock ▲ Speed  3000.0 →Acc   20000 Dec    20000 ▼                     </pre>
8)	On the input screen, press [1] [ <sup>A</sup> 4] [ <sup>B</sup> 5] [ <sup>C</sup> 6] [ <sup>D</sup> 7] on the ten-key pad to enter the acceleration time constant (for 14567msec). Press [↵] to write the acceleration time constant and press [CAN] to proceed to step 9).	<pre> 5 Acc time ▲ 20000 14567 Write:← msec ▼                     </pre>
9)	On the data list screen, press [▲]/[▼] to select the data field into which data is to be input (select the deceleration time constant). Press [↵] to define the data field into which data is to be input (define the deceleration time constant).	<pre> 5 SpeedBlock ▲ Speed  3000.0 Acc    14567 →Dec  20000 ▼                     </pre>
10)	On the input screen, press [1] [ <sup>A</sup> 4] [ <sup>B</sup> 5] [ <sup>C</sup> 6] [ <sup>D</sup> 7] on the ten-key pad to enter the deceleration time constant (for 14567msec). Press [↵] to write the deceleration time constant. Speed block input complete Press [CAN] twice to return to step 4).	<pre> 5 Dec time ▲ 20000 14567 Write:← msec ▼                     </pre>
11)	If the key pressed is wrong, press [STOP/RESET] to return to the input screen, or press [CAN] to return to the data list screen.	<pre> 5 Dec time ▲ 20000 99999 Error :RST ▼                     </pre>



### 3. POSITIONING SYSTEM

#### (3) Data copy

This function reads the point table data (position blocks, speed blocks) of the MR-H-ACN to the parameter unit and writes them from the parameter unit. By using this function, data can be read once to the parameter unit and then copied to the other MR-H-ACN.

##### (a) Data read

Reads data from the MR-H-ACN to the parameter unit.

Step	Parameter Unit Operation	Parameter Unit Screen
1)	Press [PARAM/DATA]. Press [SHIFT] [3] (position data copy initial screen). Press [CAN] to return to the previous screen.	<pre>           &lt;Set mode&gt; ▲           →Pos. Block            Speed Block           Edit :HELP ▼           </pre>
2)	Press [▲]/[▼] to specify the mode (specify). Press [↵] to define the mode. If the key press is wrong, press [STOP/RESET] or [CAN] to return to step 1).	<pre>           &lt;DATA COPY&gt; ▲           →READ            WRITE            COMPARE ▼           </pre> <pre>           &lt;DATA COPY&gt;           Read ?              Yes: J              No: RST           </pre>
3)	Read complete Press [CAN] to return to step 1).	<pre>           &lt;DATA COPY&gt;           COMPLETE           Mode sel.:CAN           </pre>

### 3. POSITIONING SYSTEM

(b) Data verify

Verifies the data in the parameter unit with that in the MR-H-ACN.

Step	Parameter Unit Operation	Parameter Unit Screen
1)	Press [PARAM/DATA]. Press [SHIFT] [3] (position data copy initial screen). Press [CAN] to return to the previous screen.	<div style="border: 1px solid black; padding: 5px;">           &lt;Set mode&gt; ▲            → Pos. Block            Speed Block            Edit :HELP ▼         </div>
2)	Press [▲]/[▼] to specify the mode (specify). Press [↵] to define the mode.	<div style="border: 1px solid black; padding: 5px;">           &lt;DATA COPY&gt; ▲            → READ            WRITE            COMPARE ▼         </div> <div style="border: 1px solid black; padding: 5px;">           &lt;DATA COPY&gt;  <div style="background-color: black; color: white; padding: 2px; display: inline-block;">Comparing</div>            Not Power Off         </div>
3)	<div style="border: 1px solid black; padding: 2px;">Verify complete</div> Press [CAN] to return to step 1).	<div style="border: 1px solid black; padding: 5px;">           &lt;DATA COPY&gt;  <div style="background-color: black; color: white; padding: 2px; display: inline-block;">COMPLETE</div>            Mode sel.:CAN         </div>
4)	<div style="border: 1px solid black; padding: 2px;">When incorrect data exists in the data verified</div> Press [SHIFT] to check incorrect data numbers. When incorrect data overflows a single screen, press [▲]/[▼] to switch to the preceding/next screen. Press [CAN] to return to step 1).	<div style="border: 1px solid black; padding: 5px;">           &lt;DATA COPY&gt;  <div style="background-color: black; color: white; padding: 2px; display: inline-block;">Compare Er.</div>            Error No. :SFT            Mode sel.:CAN         </div> <div style="border: 1px solid black; padding: 5px;"> <div style="background-color: black; color: white; padding: 2px; display: inline-block;">Er. Data No.</div> ▲            P010P P010S            P050M P185M            P185S S002V ▼         </div>

Error number make-up

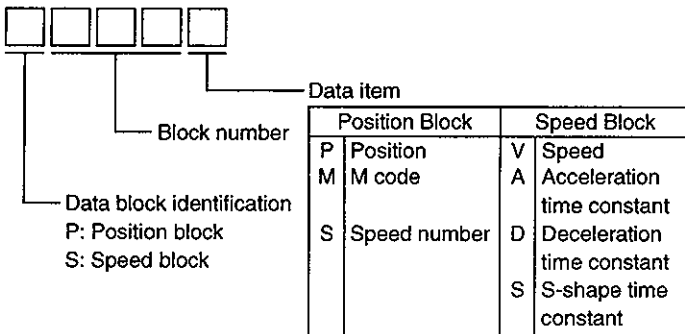

### 3. POSITIONING SYSTEM

(c) Data write

Writes the data in the parameter unit to the MR-H-ACN.

Step	Parameter Unit Operation	Parameter Unit Screen
1)	Press [PARAM/DATA]. Press [SHIFT][3] (position data copy initial screen). Press [CAN] to return to the previous screen.	<div style="border: 1px solid black; padding: 5px;">           &lt;Set mode&gt; ▲            → Pos. Block            Speed Block            Edit :HELP ▼         </div>
2)	Press [▲]/[▼] to specify the mode (specify). Press [↵] to define the mode.	<div style="border: 1px solid black; padding: 5px;">           &lt;DATA COPY&gt; ▲            → READ            WRITE            COMPARE ▼         </div>
3)	When write is inhibited Press [CAN] to return to step 1).	<div style="border: 1px solid black; padding: 5px;">           &lt;DATA COPY&gt;  <b>Write inhibit</b>            SON ALM            Press "CAN"         </div>
4)	Press [↵] to execute write. Press [STOP/RESET] to stop write and return to step 1).	<div style="border: 1px solid black; padding: 5px;">           &lt;DATA COPY&gt;            Write ?            Yes: J            No: RST         </div> <div style="border: 1px solid black; padding: 5px; margin-top: 5px;">           &lt;DATA COPY&gt;  <b>Writing</b>            Not Power Off         </div>
5)	<b>Write complete</b> Press [CAN] to return to step 1).	<div style="border: 1px solid black; padding: 5px;">           &lt;DATA COPY&gt;  <b>COMPLETE</b>            →Power Off         </div>
6)	<div style="border: 1px solid black; padding: 2px; display: inline-block;"> <b>When incorrect data exists in the data written</b> </div> 1. Press [↵] to write only the correct data. 2. Press [STOP/RESET] to stop write and return to step 1). 3. Press [SHIFT] to check incorrect data numbers. When incorrect data overflows a single screen, press [▲]/[▼] to switch to the preceding/next screen.	<div style="border: 1px solid black; padding: 5px;"> <b>ErrorNo.:SFT</b>            Right Data            Write Yes:J            No:RST         </div> <div style="border: 1px solid black; padding: 5px; margin-top: 5px;"> <b>Wrong Data</b> ▲            P000P P001P            S001V S001A            S101D S002V ▼         </div>

Error number make-up

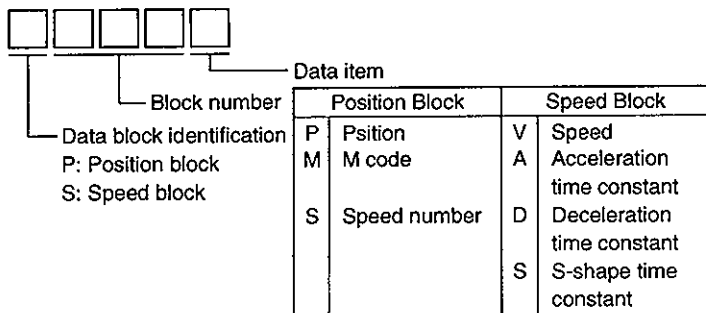

### 3. POSITIONING SYSTEM

#### (4) Point table data edition

##### (a) Position block data insertion

Inserts data into the specified position block on a block basis.

Step	Parameter Unit Operation	Parameter Unit Screen
1)	Press [PARAM/DATA]. Press [HELP] (position block edition initial screen). Press [CAN] to return to the previous screen.	<pre> &lt;Set mode&gt; ▲ →Pos. Block Speed Block Edit :HELP ▼                     </pre>
2)	Press [▲]/[▼] to specify the mode (specify). Press [↵] to define the mode (define).	<pre> &lt;Pos. Edit&gt; ▲ →INSERT DELETE ▼                     </pre>
3)	Press [2] [5] [0] on the ten-key pad to specify the block number into which data is to be inserted (for No.250). Press [↵] to execute insertion.	<pre> &lt;Block Ins.&gt; Block No.       250 Yes:↵ No:RST                     </pre>
4)	<div style="border: 1px solid black; padding: 2px; display: inline-block;">During insertion</div> Data in block No.250 is shifted to No.1 and No.250 is vacated. On completion of insertion, the positioning address list screen is displayed.	<pre> &lt;Block Ins.&gt; Inserting Not Power Off  250→      0.0 ▲ 251      78901.2 252      34567.8 253      90123.4 ▼                     </pre>
5)	<div style="border: 1px solid black; padding: 2px; display: inline-block;">When insertion cannot be performed (outside the block number setting range)</div> Press [STOP/RESET] to return to step 3).	<pre> &lt;Block Ins.&gt; Block No.       300 Error:RST                     </pre>
6)	<div style="border: 1px solid black; padding: 2px; display: inline-block;">When the data of the last block will be deleted by executing insertion</div> Press [↵] to return to step 3). Press [STOP/RESET] to execute insertion.	<pre> &lt;Block Ins.&gt; No. 255 Delete Yes:↵ No:RST                     </pre>

### 3. POSITIONING SYSTEM

#### Concept of data insertion

When inserting data, data in and after the block where data is to be inserted is shifted to the following blocks. When any unused blocks exist in block No.s 0 through 255, the data of the first unused block is deleted and data is shifted to that block. The data of the following unused blocks and subsequent used blocks are not shifted. When data exists in all blocks, block No.255 is deleted.

Example: When inserting the following data into block No.002

Position Data	M code	Speed Block No.
1150.0	00	05

Before insertion				After insertion			
Position Block No.	Position Data	M Code	Speed Block No.	Position Block No.	Position Data	M Code	Speed Block No.
000	1000.0	00	01	000	1000.0	00	01
001	1100.0	00	01	001	1100.0	00	01
002	1200.0	00	02	002	1150.0	00	05
003	1300.0	00	03	003	1200.0	00	02
004	1400.0	00	04	004	1300.0	00	03
005	1500.0	00	02	005	1400.0	00	04
006	0.0	00	00	006	1500.0	00	02
007	0.0	00	00	007	0.0	00	00
008	0.0	00	00	008	0.0	00	00
009	2000.0	00	01	009	2000.0	00	01
010	2100.0	00	01	010	2100.0	00	01
011	2200.0	00	02	011	2200.0	00	02
⋮	⋮	⋮	⋮	⋮	⋮	⋮	⋮
255	2200.0	00	02	255	2200.0	00	02

Data inserted →

Unused blocks

Unused blocks

Data is shifted down to position block No.007 and one unused position block is deleted.

Data in and after position block No.007 remain unchanged.

### 3. POSITIONING SYSTEM

(b) Position block data deletion

Deletes the position data of the specified position block number.

Step	Parameter Unit Operation	Parameter Unit Screen
1)	Press [PARAM/DATA]. Press [HELP] (position block edition initial screen). Press [CAN] to return to the previous screen.	<pre> &lt;Set mode&gt; ▲ → Pos. Block Speed Block Edit :HELP ▼                     </pre>
2)	Press [▲]/[▼] to specify the mode (specify). Press [↵] to define the mode (define).	<pre> &lt;Pos. Edit&gt; ▲ INSERT →DELETE ▼                     </pre>
3)	Press [2] [5] [0] on the ten-key pad to specify the block number from which data is to be deleted (for No.250). Press [↵] to execute deletion.	<pre> &lt;Block Del.&gt; Block No.       250 Yes:↵ No:RST                     </pre>
4)	<p><b>During deletion</b></p> <p>The data of block No. 250 is deleted, the data from No. 251 on are shifted up one place, and No. 255 is vacated.</p> <p>On completion of deletion, the positioning address list screen is displayed.</p>	<pre> &lt;Block Del.&gt; Deleting Not Power Off  250→ 3000.0 ▲ 251 4000.0 252 5000.0 253 6000.0 ▼                     </pre>
5)	<p><b>When deletion cannot be performed (outside the block number setting range)</b></p> <p>Press [STOP/RESET] to return to step 3)</p>	<pre> &lt;Block Del.&gt; Block No.       300 Error:RST                     </pre>

### 3. POSITIONING SYSTEM

#### Concept of data deletion

When deleting data, data in and after the block where data is deleted is shifted to the preceding blocks. When any unused blocks exist in block No.s 0 through 255, an unused block is added and data before that additional unused block is shifted.

The data of the unused blocks and subsequent used blocks are not shifted.

When data exists in all blocks, an unused block is added to block No.255.

Example: When deleting the data of block No.002

		Before deletion				After deletion			
		Position Block No.	Position Data	M Code	Speed Block No.	Position Block No.	Position Data	M Code	Speed Block No.
Data to be deleted	→	000	1000.0	00	01	000	1000.0	00	01
		001	1100.0	00	01	001	1100.0	00	01
		002	1150.0	00	05	002	1200.0	00	02
Unused blocks		003	1200.0	00	02	003	1300.0	00	03
		004	1300.0	00	03	004	1400.0	00	04
		005	1400.0	00	04	005	1500.0	00	02
		006	1500.0	00	02	006	0.0	00	00
		007	0.0	00	00	007	0.0	00	00
		008	0.0	00	00	008	0.0	00	00
		009	2000.0	00	01	009	2000.0	00	01
		010	2100.0	00	01	010	2100.0	00	01
		011	2200.0	00	02	011	2200.0	00	02
		:	:	:	:	:	:	:	:
	255	2200.0	00	02	255	2200.0	00	02	

One unused position block (No.006) is added.

Data in and after position block No.007 remain unchanged.

## 4. ROLL FEEDING SYSTEM

### 4. ROLL FEEDING SYSTEM

#### 4.1 Roll Feeding System Specifications

Item		Specifications	
Command system	Point table number input	Operational specifications	Position block number is specified for positioning.
		Position command input	<ul style="list-style-type: none"> <li>Using the contact input, positions are selected from those in 2 position blocks.</li> <li>Feed length setting range for 1 position: <math>\pm 1\mu\text{m}</math> to <math>\pm 999.999\text{m}</math></li> </ul>
		Speed command input	<ul style="list-style-type: none"> <li>The contact input allows speeds and acceleration/deceleration times to be selected from those in 2 speed blocks as standard or from those in 8 speed blocks when the option card (MR-H-D01) is used.</li> </ul>
		System	Incremental command
	Position data input (D01 card required)	Operational specifications	Digital switch or contact data input is used for positioning.
		Position command input	<ul style="list-style-type: none"> <li>6-digit BCD (unsigned) digital switch (MR-SD60) or contact input</li> <li>Feed length input setting range: <math>1\mu\text{m}</math> to <math>\pm 999.999\text{m}</math></li> </ul>
		Speed command input	Using the contact input, speeds and acceleration/deceleration times are selected from those in 2 speed blocks as standard or from those in 8 speed blocks when the option card (MR-H-D01) is used.
		System	Incremental command
Operation mode	Automatic mode		Positioning operation is performed once under the speed/position commands.
	Manual mode	Jog	Jog operation is performed by the parameter unit or contact input under the speed command.
		Manual pulse generator (MR-HDP01)	<p>Manual pulse generator (MR-HDP01) is used for manual feed.</p> <ul style="list-style-type: none"> <li>Input pulse specifications: 2-phase pulse train with 90° phase difference (A phase, B phase) ····· multiplied by 4</li> <li>Input pulse form: open collector input</li> <li>Max. Input pulse frequency: open collector input 200kepps 120000r/min for MR-HDP01</li> <li>Command pulse magnification: any of <math>\times 1</math>, <math>\times 10</math> and <math>\times 100</math> is selected using the internal parameter. The option card (MR-H-D01) may be used to select the above externally.</li> </ul>
Functions of positioning control		<ul style="list-style-type: none"> <li>Acceleration/deceleration method setting (S-shaped acceleration/deceleration, separate settings for acceleration and deceleration)</li> <li>Backlash compensation</li> <li>Alarm code is output using the option card (MR-H-D01)</li> <li>Input contact assignment changed by internal parameter</li> </ul>	



## 4. ROLL FEEDING SYSTEM

### 4.2 Standard Connection Example



#### WARNING

- Any person who is involved in wiring should be fully competent to do the work.
- Before starting wiring, make sure that the charge lamp is off more than 10 minutes after power-off, and then confirm that the voltage across terminals P-N is safe with a tester or similar device. A failure to do so can cause an electric shock.
- Do not attempt to wire the controller and servo motor until they have been installed. Otherwise, you may get an electric shock.
- The cables should not be damaged, stressed excessively, loaded heavily, or pinched. Otherwise, you may get an electric shock.



#### CAUTION

- Wire the equipment correctly and securely. Otherwise, the servo motor may misoperate, resulting in injury.
- Connect cables to correct terminals to prevent a burst, fault, etc.
- Ensure that polarity (+, -) is correct. Otherwise, a burst, fault, etc. may occur.
- The surge absorbing diode installed to the DC relay designed for control output should be fitted in the specified direction. Otherwise, the signal is not output due to a fault, disabling the emergency stop and other protective circuits.

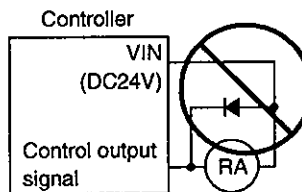

- Use a noise filter, etc. to minimize the influence of electromagnetic interference, which may be given to electronic equipment used near the controller.
- Do not install a power capacitor, surge suppressor or radio noise filter (FR-BIF option) with the power line of the controller.
- When using the regenerative brake resistor, switch power off with the alarm signal. Otherwise, a transistor fault or the like may overheat the regenerative brake resistor, causing a fire.
- Do not modify the equipment.

# 4. ROLL FEEDING SYSTEM

## 4.2.1 Standard configuration (without the MR-H-D01 option card)

Roll feeding operation according to 2-position point table

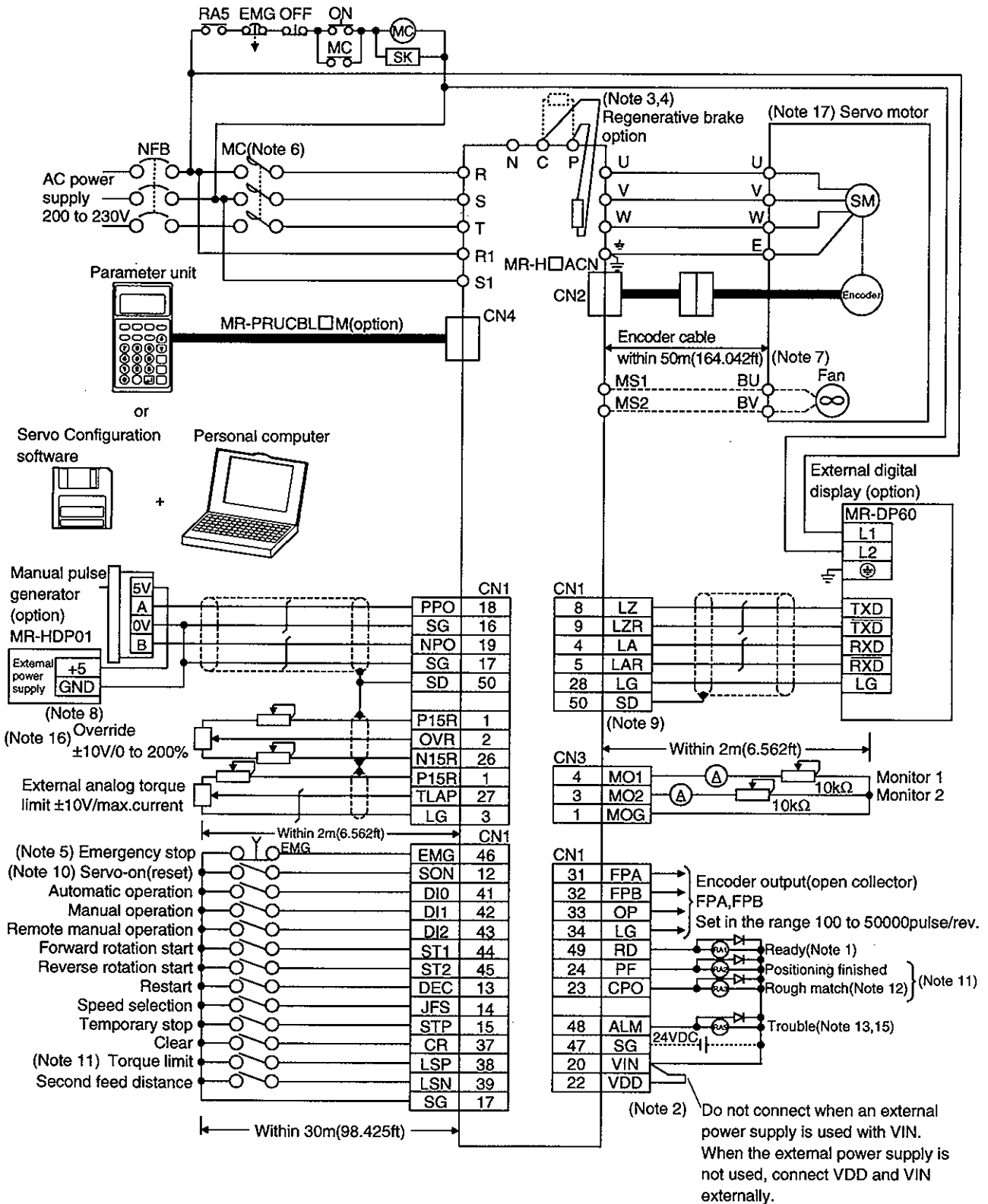

For notes, refer to page 4-8.

# 4. ROLL FEEDING SYSTEM

## 4.2.2 Extension configuration 1 (with the MR-H-D01 option card)

Roll feeding operation under digital switch (MR-DS60) position data command.

The digital switch used must be the optional MR-DS60.

Set 1□□1 in parameter No.65.

Parameter No.65

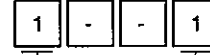

BCD 3 digits x2 input  
Digital switch is used.

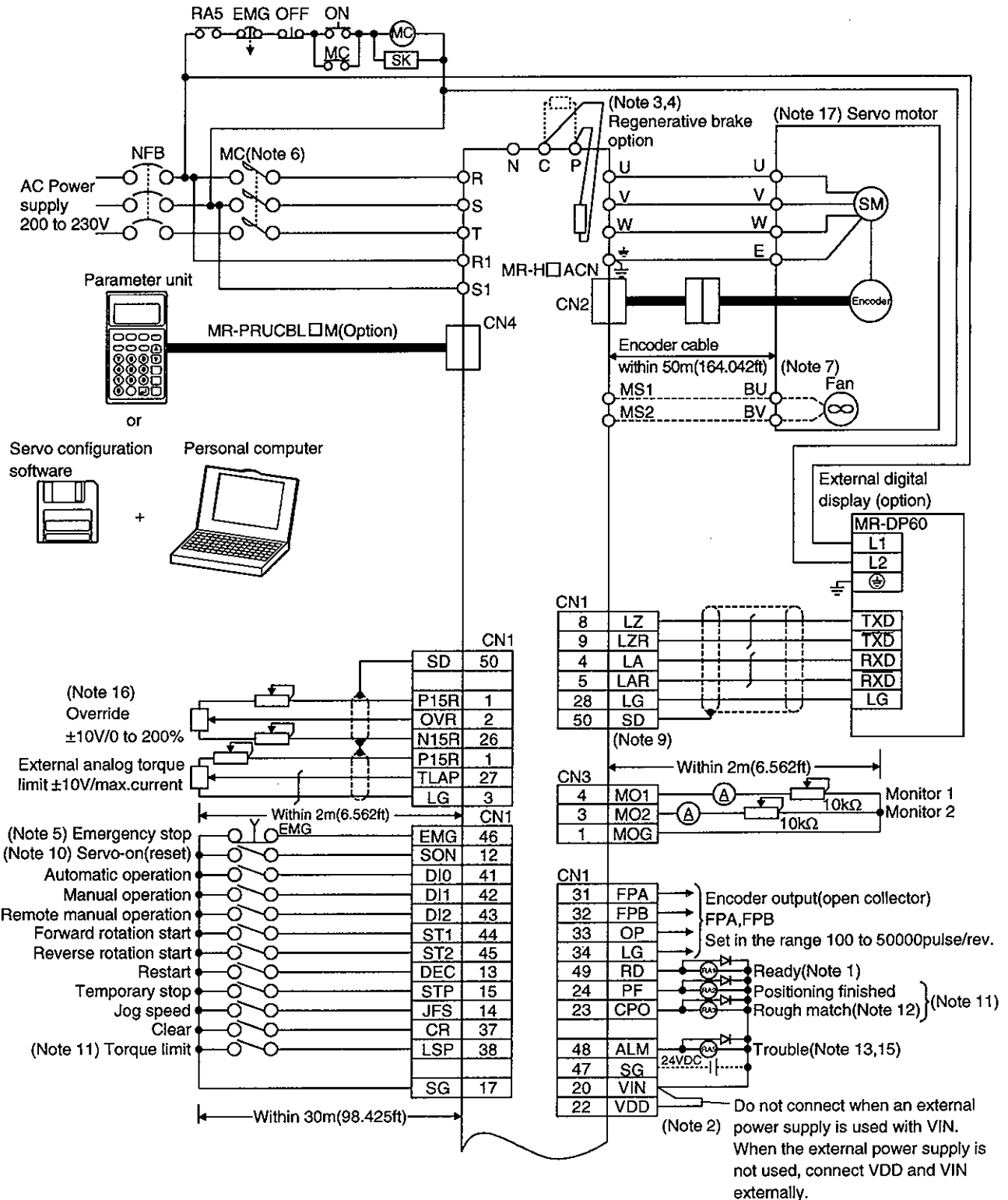

# 4. ROLL FEEDING SYSTEM

When the MR-H-D01 option card is used, set functions in parameters No.s 65 to 68.

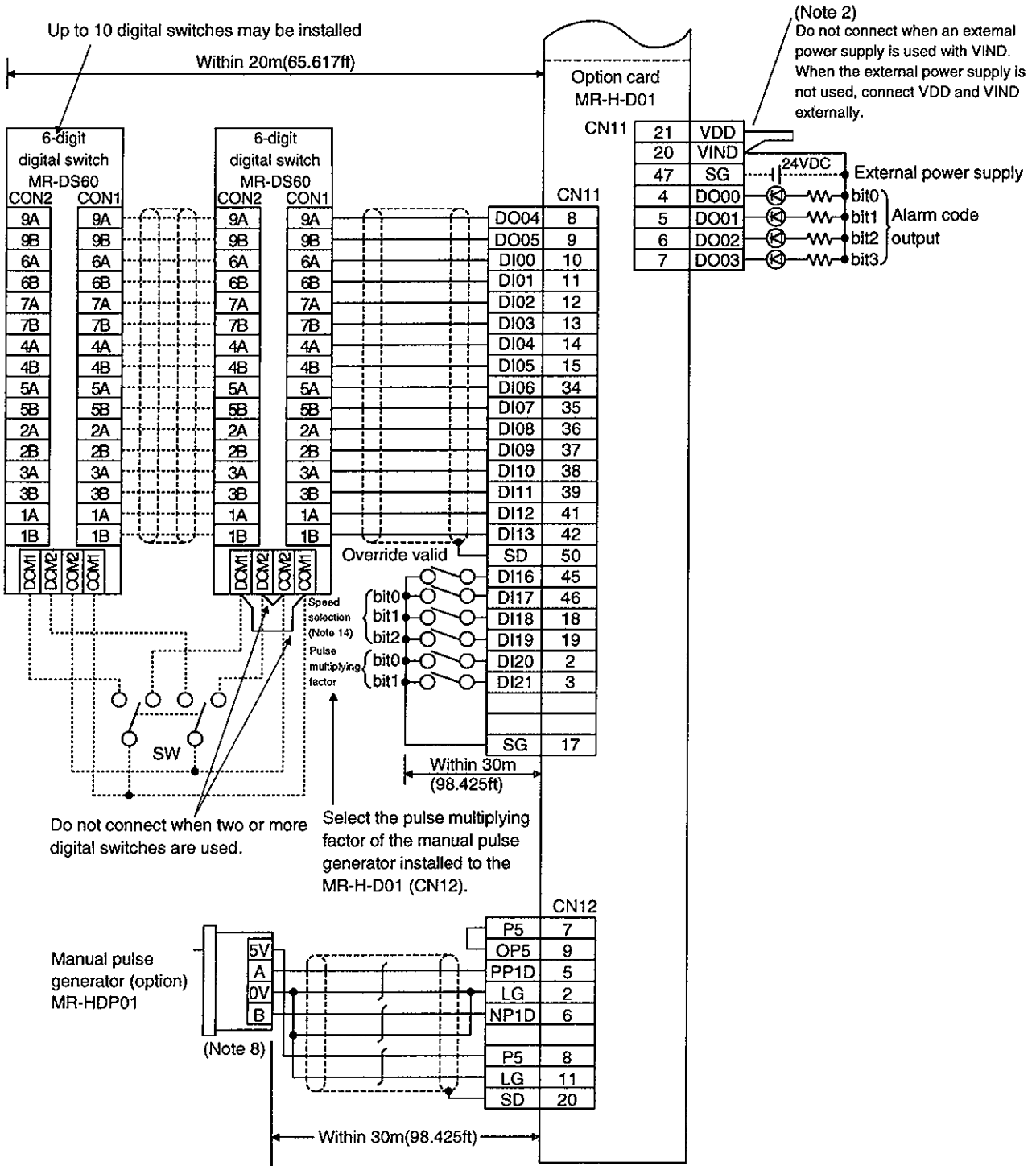

For notes, refer to page 4-8.

# 4. ROLL FEEDING SYSTEM

## 4.2.3 Extension configuration 2 (with the MR-H-D01 option card)

Roll feeding operation under programmable controller position data command

The wiring example shown in this section assumes that Mitsubishi's A1S series programmable controllers are used.

Set 0□□1 in parameter No.65.

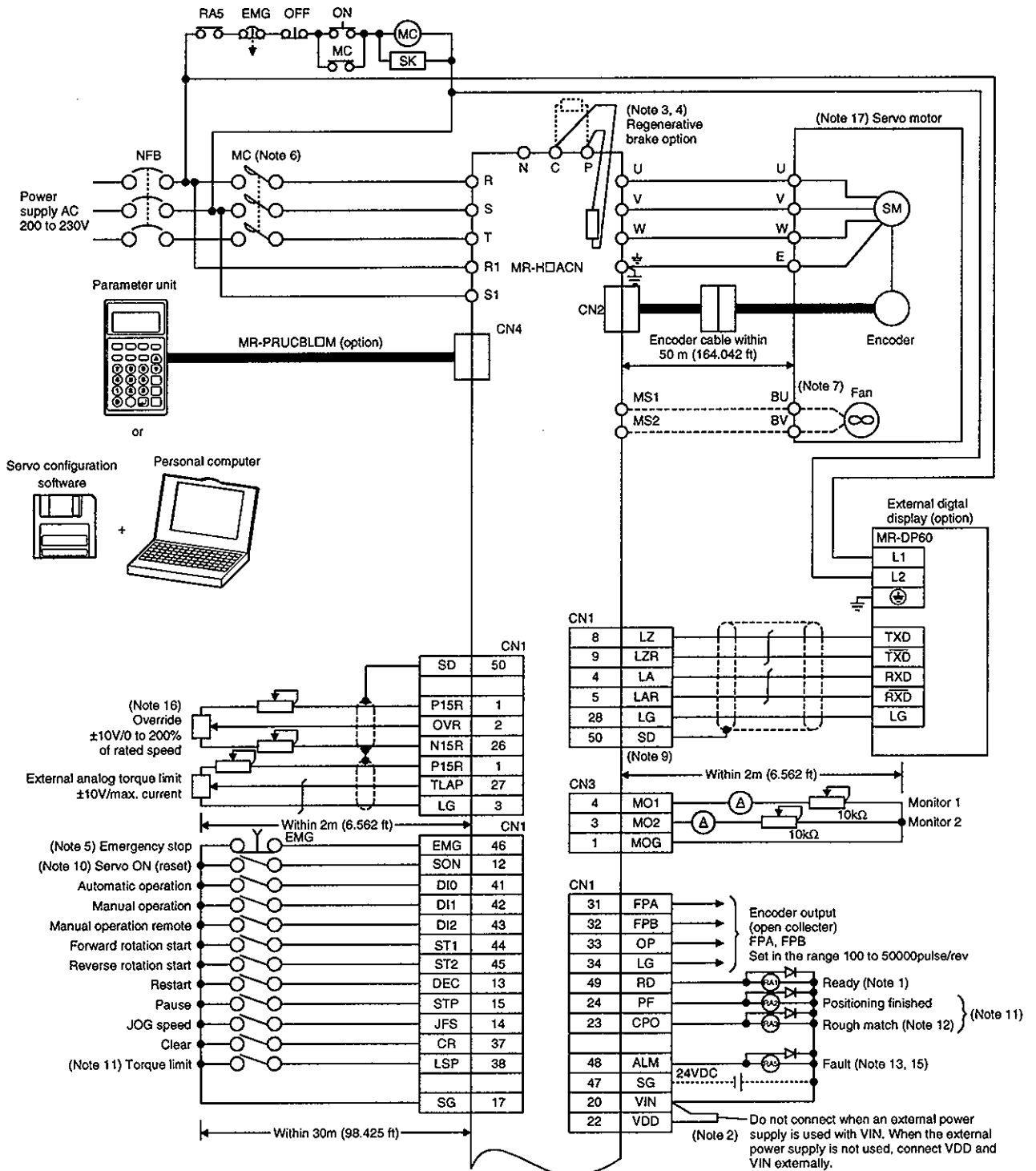
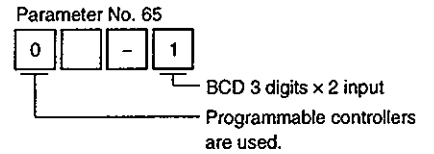

# 4. ROLL FEEDING SYSTEM

When the MR-H-D01 option card is used, set functions in parameter No. s 65-68.

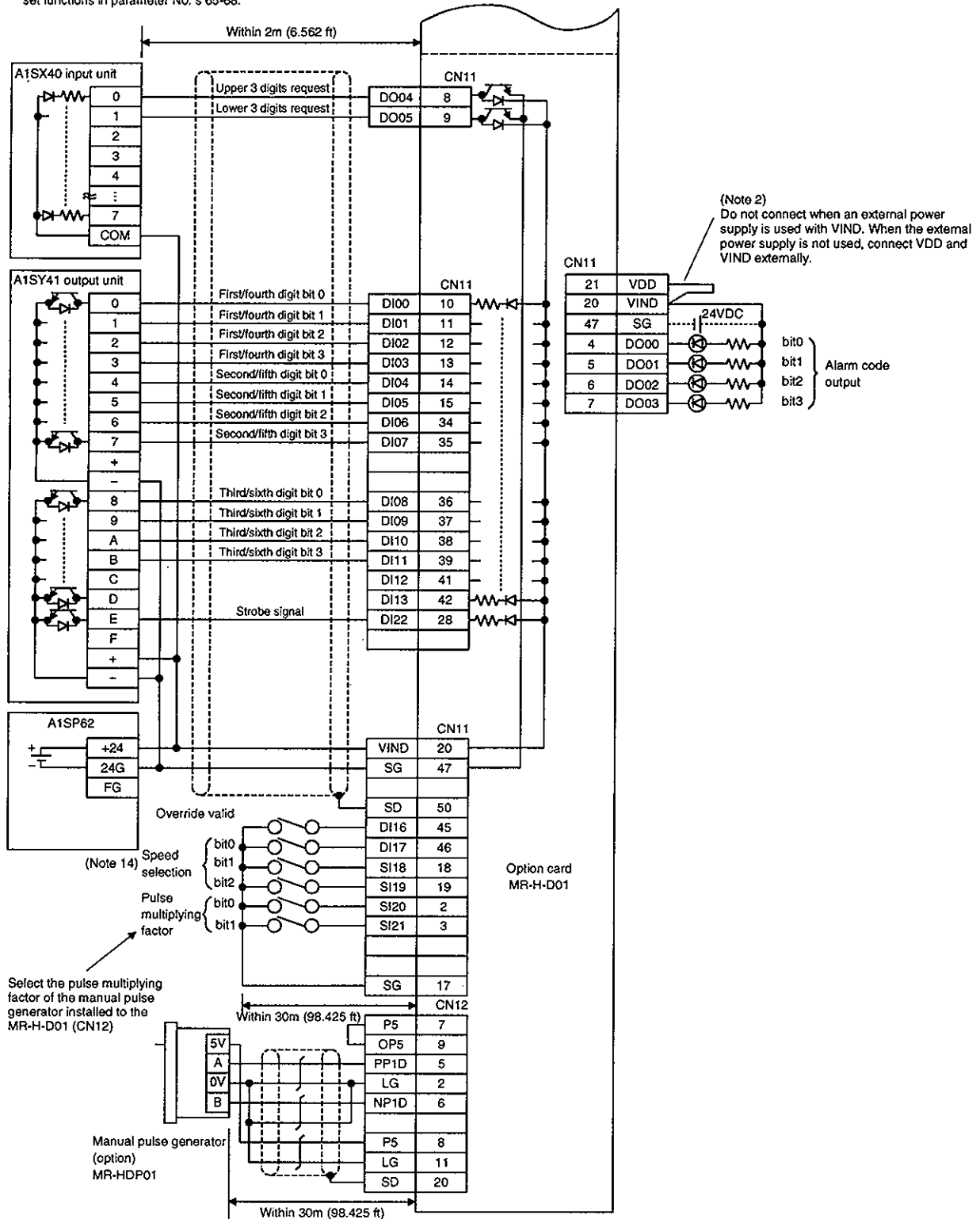

For notes, refer to page 4-8.

## 4. ROLL FEEDING SYSTEM

---

- Note:
1. Connect the diode in the correct orientation. If the diode is reversed, a fault will occur and signals not output, and the emergency stop and other protective circuits may be disabled.
  2. The sum total of currents flowing in the external relays should be 200mA max. If 200mA is exceeded, supply external power to the interface.
  3. The controller of 11kW or more does not contain the regenerative brake resistor. Connect the supplied external regenerative brake resistor.
  4. Connect the regenerative brake option across terminals P-C after disconnecting the leads of the built-in regenerative brake resistor from P-C.
  5. The emergency stop switch must be installed.
  6. Make up a power circuit which will switch off the magnetic contactor after detection of alarm occurrence.
  7. For the HA-LH series servo motors of 11kW or more, supply power to the fan terminals. For 11kW or more, connect the fan terminals to the MS1 and MS terminals of the controller. Refer to Section 5.4.4 for connection with the servo motor.
  8. When the MR-H-D01 option card is used, power can be supplied from the MR-H-D01.
  9. Change the setting of parameter No.52 to 0 to use LA, LAR, LB, LBR, LZ and LZR as encoder pulse outputs.
  10. Change the setting of parameter No.41 to 1 to use SON as a reset signal.
  11. Change the setting of parameter No.41 to 11 to use LSP as a forward rotation stroke end signal and LSN as a reverse rotation stroke end signal.
  12. Change the setting of parameter No.3 to 1 to use CPO as an electromagnetic brake interlock or the setting of parameter No.44 to 1 to use CPO as a torque limit-in-progress.
  13. Change the setting of parameter No.44 to 1 to use ALM as an pre-alarm output.
  14. Speed selection is made valid by setting 1 in parameter No.65.  
When the initial value (0) is used, speed block No.1 is selected.
  15. The trouble (ALM) signal is on under normal conditions.
  16. The upper limit of the overriding speed is the permissible speed.

# 4. ROLL FEEDING SYSTEM

## 4.3 I/O Connectors

### 4.3.1 Connector signal layouts

**POINT**

- The signal layouts of the connectors are views from the wiring section of the cable connectors.

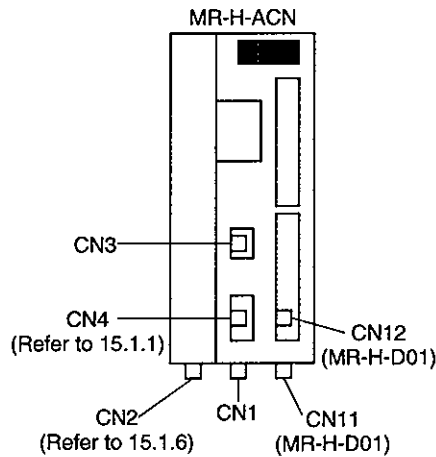

CN2 (for encoder signals)  
Model PCR-S20FS (Honda Tsushin make)

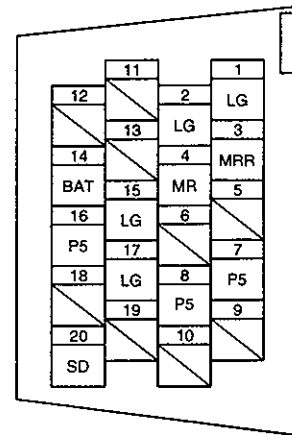

CN1  
Model PCR-S50FS (Honda Tsushin make)

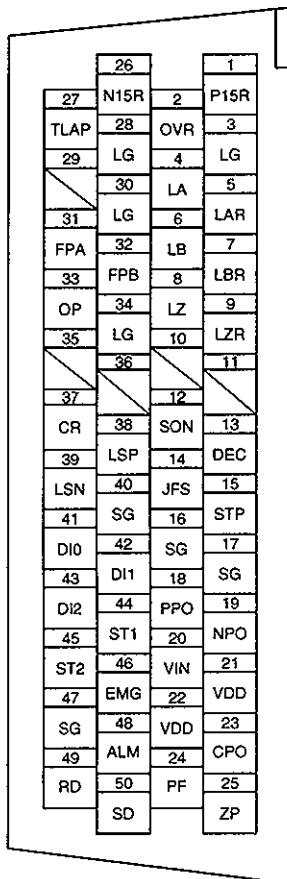

CN11  
Model PCR-S50FS (Honda Tsushin make)

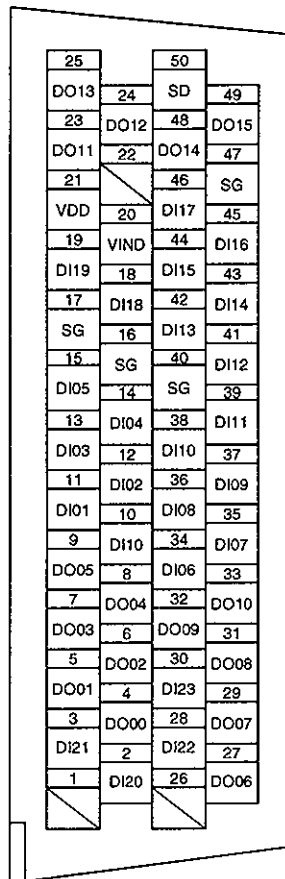

CN12  
Model PCR-S20FS (Honda Tsushin make)

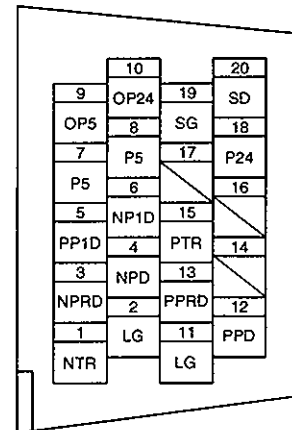

CN3  
Model 171822-4 (AMP make)

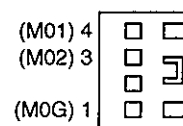



## 4. ROLL FEEDING SYSTEM

### 4.3.2 Signal explanations

Refer to Section 5.2.2 for the I/O interfaces (symbols in the I/O column of the table).

(1) CN1

Signal Name	Symbol	Pin No.	Description	I/O Division																																
Digital I/F power supply input	VIN	20	Driver power supply input terminal for digital interface Input 24VDC $\pm 10\%$ for input interface. When using an external power supply, connect a 24VDC power supply of 200mA or more to this terminal. When using the internal power supply (VDD) as the interface power supply, always connect VDD.																																	
Driver power supply	VDD	21,22	+24V $\pm 10\%$ is output across VDD-SG. Connect with VIN when using this power supply for the digital interface. Permissible current: 200mA																																	
Open collector power input	OPC	11	When using a manual pulse generator, supply 24VDC to this terminal.																																	
24V common	SG	16,17 40,47	Common terminals for VDD and VIN. Isolated from LG.																																	
DC power supply	P15R	1	+15VDC is output across P15R-LG. Use as a power supply for OVR/TLAP. Permissible current: 30mA																																	
	P15N	26	-15VDC is output across P15N-LG. Use as a power supply for OVR/TLAP. Permissible current: 30mA																																	
Control common	LG	3,28 30,34	Common terminals for OVR, TLAP, LA, LAR, LB, LBR, LZ, LZR, FPA, FPB and OP.																																	
Shield	SD	50	Connect the servo amplifier end of the shield cable.																																	
Servo on	SON	12	Operation-ready signal input terminal. Short SON-SG to switch the base circuit on, making the servo amplifier ready to operate. Open them to shut off the base circuit, coasting the servo motor.	DI-1																																
Reset			Alarm reset signal input terminal. When using the reset signal, set $\square\square\square 1$ in parameter No. 41. At this time, the servo on signal is "automatically turned on internally". Short SON-SG for longer than 20ms to reset the alarm. While SON-SG are shorted, the base circuit is shut off. However, regenerative alarm (AL30), overload 1 (AL50) and overload 2 (AL51) cannot be reset until the regenerative brake resistor and power transistor temperatures reduce. The following alarms can be reset.	DI-1																																
<table border="1" style="width: 100%; border-collapse: collapse;"> <thead> <tr> <th>Display</th> <th>Function Name</th> <th>Display</th> <th>Function Name</th> </tr> </thead> <tbody> <tr> <td>AL10</td> <td>Under voltage</td> <td>AL45</td> <td>Main circuit device overheat</td> </tr> <tr> <td>AL24</td> <td>Ground fault</td> <td>AL46</td> <td>Servo motor overheat</td> </tr> <tr> <td>AL31</td> <td>Over speed</td> <td>AL52</td> <td>Error excessive</td> </tr> <tr> <td>AL32</td> <td>Over current</td> <td>AL73</td> <td>Auxiliary pulse frequency alarm 1</td> </tr> <tr> <td>AL33</td> <td>Over voltage</td> <td>AL75</td> <td>Option memory alarm 2</td> </tr> <tr> <td>AL35</td> <td>command pulse frequency alarm</td> <td>AL8E</td> <td>RS-232C alarm</td> </tr> <tr> <td>AL42</td> <td>Feedback alarm</td> <td>AL8F</td> <td>RS-422 alarm</td> </tr> </tbody> </table>					Display	Function Name	Display	Function Name	AL10	Under voltage	AL45	Main circuit device overheat	AL24	Ground fault	AL46	Servo motor overheat	AL31	Over speed	AL52	Error excessive	AL32	Over current	AL73	Auxiliary pulse frequency alarm 1	AL33	Over voltage	AL75	Option memory alarm 2	AL35	command pulse frequency alarm	AL8E	RS-232C alarm	AL42	Feedback alarm	AL8F	RS-422 alarm
Display	Function Name	Display	Function Name																																	
AL10	Under voltage	AL45	Main circuit device overheat																																	
AL24	Ground fault	AL46	Servo motor overheat																																	
AL31	Over speed	AL52	Error excessive																																	
AL32	Over current	AL73	Auxiliary pulse frequency alarm 1																																	
AL33	Over voltage	AL75	Option memory alarm 2																																	
AL35	command pulse frequency alarm	AL8E	RS-232C alarm																																	
AL42	Feedback alarm	AL8F	RS-422 alarm																																	

## 4. ROLL FEEDING SYSTEM

Signal Name	Symbol	Pin No.	Description	I/O Division																								
Torque limit	LSP	38	Torque limit signal input terminal. When using the torque limit signal, set $\square 0 \square \square$ in parameter No. 41. At this time, the forward rotation stroke end signal is made invalid. Short LSP-SG to limit the generated torque according to the voltage of the torque limit command (TLAP). Open LSP-SG to make the parameter No. 40 setting valid.	DI-1																								
Second feed distance	LSN	39	Second feed distance selection signal input terminal. Used to choose the position block No. to be executed. Open LSN-SG to choose position block No. 0. Short LSN-SG to choose position block No. 1.																									
Forward rotation stroke end	LSP	38	Stroke end signal input terminals. When using the forward/reverse rotation stroke end signal, make them valid in parameter No.41. At this time, the torque limit signal/second feed distance selection signal is made invalid. To start operation, short LSP-SG and/or LSN-SG. Open them to bring the motor to a sudden stop and make it servo-locked. When these signals are not used, you can specify "automatically turned on internally" in parameter No. 42.	DI-1																								
Reverse rotation stroke end	LSN	39	<table border="1" style="margin-left: auto; margin-right: auto;"> <thead> <tr> <th colspan="2">(Note) External Input Signals</th> <th colspan="2">Operation</th> </tr> <tr> <th>LSP</th> <th>LSN</th> <th>CCW direction</th> <th>CW direction</th> </tr> </thead> <tbody> <tr> <td>1</td> <td>1</td> <td style="text-align: center;">○</td> <td style="text-align: center;">○</td> </tr> <tr> <td>0</td> <td>1</td> <td style="text-align: center;">/</td> <td style="text-align: center;">○</td> </tr> <tr> <td>1</td> <td>0</td> <td style="text-align: center;">○</td> <td style="text-align: center;">/</td> </tr> <tr> <td>0</td> <td>0</td> <td style="text-align: center;">/</td> <td style="text-align: center;">/</td> </tr> </tbody> </table> <p>Note. 0: LSP/LSN-SG off (open) 1: LSP/LSN-SG on (short)</p>	(Note) External Input Signals		Operation		LSP	LSN	CCW direction	CW direction	1	1	○	○	0	1	/	○	1	0	○	/	0	0	/	/	DI-1
(Note) External Input Signals		Operation																										
LSP	LSN	CCW direction	CW direction																									
1	1	○	○																									
0	1	/	○																									
1	0	○	/																									
0	0	/	/																									
Clear	CR	37	Clear signal input terminal. Short CR-SG for longer than 5ms to clear the droop pulses. Using parameter No. 42, you can make selection between "cleared when signal is switched from off to on" and "always cleared while signal is on".	DI-1																								
Speed selection	JFS	14	Speed selection signal input terminal. Used to choose the speed block No. to be executed. Open JFS-SG to choose speed block No. 1. Short JFS-SG to choose speed block No. 2.	DI-1																								
Temporary stop	STP	15	Temporary stop signal input terminal Short STP-SG which are open to stop operation. Turn on the restart signal (DEC) which is off to resume operation from where it had stopped. Reserve the pulse width of 5ms or longer.	DI-1																								
Restart	DEC	13	Restart signal input terminal Short DEC-SG which are open to resume operation from where it had stopped. Reserve the pulse width of 5ms or longer.	DI-1																								
Reverse rotation start	ST2	45	In the manual remote mode, short ST1-SG to rotate the servo motor in the CCW direction. Short ST2-SG to rotate it in the CW direction. <table border="1" style="margin-left: auto; margin-right: auto;"> <thead> <tr> <th colspan="2">(Note) External Input Signals</th> <th>Rotation Direction</th> </tr> <tr> <th>ST2</th> <th>ST1</th> <th></th> </tr> </thead> <tbody> <tr> <td>1</td> <td>1</td> <td style="text-align: center;">(Stop) Servo lock</td> </tr> <tr> <td>0</td> <td>1</td> <td style="text-align: center;">CCW</td> </tr> <tr> <td>1</td> <td>0</td> <td style="text-align: center;">CW</td> </tr> <tr> <td>0</td> <td>0</td> <td style="text-align: center;">(Stop) Servo lock</td> </tr> </tbody> </table> <p>Note. 0: LSP/LSN-SG off (open) 1: LSP/LSN-SG on (short)</p>	(Note) External Input Signals		Rotation Direction	ST2	ST1		1	1	(Stop) Servo lock	0	1	CCW	1	0	CW	0	0	(Stop) Servo lock	DI-1 DI-1						
(Note) External Input Signals		Rotation Direction																										
ST2	ST1																											
1	1	(Stop) Servo lock																										
0	1	CCW																										
1	0	CW																										
0	0	(Stop) Servo lock																										

## 4. ROLL FEEDING SYSTEM

Signal Name	Symbol	Pin No.	Description	I/O Division
Automatic operation selection	DIO	41	Operation mode selection signal input terminal. Used to choose the operation mode. Refer to Section 4.3.3.	DI-1
Manual operation selection	DI1	42		DI-1
Remote manual operation selection	DI2	43		DI-1
Manual pulse generator signal	PPO	18	Connect the manual pulse generator (MR-HDP01). Refer to Section 15.1.12 for details.	DI-2
	NPO	19		
Emergency stop	EMG	46	Emergency stop signal input terminal Opening EMG-SG puts the motor in an emergency stop status, in which the servo is switched off, the dynamic brake is operated, and the motor comes to a sudden stop. Short EMG-SG in the emergency stop status to exit from the emergency stop status.	DI-1
Trouble	ALM	48	Trouble signal output terminal. ALM-SG is disconnected when the protective circuit is activated to shut off the base circuit at power-off. They are connected in a normal status at power-off.	DO-1
Rough match	CPO	23	Rough match signal output terminal. CPO-SG are connected when the command remaining distance is less than the rough match output range set in the parameter. Not output while the base circuit is off.	DO-1
Limiting torque			Limiting torque signal output terminal. When using the limiting torque signal, make it valid in parameter No. 44. At this time, the rough match/electromagnetic brake interlock signal is made invalid. CPO-SG are connected when the internally or externally set torque limit value is reached.	DO-1
Electromagnetic brake interlock			Electromagnetic brake interlock output signal terminal. When using the electromagnetic brake interlock signal, make it valid in parameter No. 3. At this time, the rough match/limiting torque signal is made invalid. The electromagnetic brake interlock signal is output. CPO-SG are disconnected at servo off or alarm.	DO-1
In position	PF	24	In-position signal output terminal. PF-SG are connected when the droop pulse value is less than the in-position range set in the parameter. Not output while the base circuit is off.	DO-1
Ready	RD	49	Ready output terminal. After servo on, RD-SG are connected in a trouble-free ready status.	DO-1
Encoder pulse (open collector)	FPA	31	In CCW rotation of the servo motor, FPA leads FPB by $\pi/2$ . Pulses are output in the range 100 to 5000 pulses/rev according to the parameter No. 39 setting.	DO-2
	FPB	32		
Encoder Z-phase pulse (differential line driver)	OP	33	Z-phase pulse signal output terminal. Output the zero-point signal of the servo motor encoder. OP-SG are connected in the zero-point position. The minimum pulse width is approx. 1.77 ms.	DO-2
External digital display signal	LA	4	External digital display signal output terminal. When using the MR-DP60 external digital display, connect it to this terminal.	DO-2
	LAR	5		
	LZ	8		
	LZR	9		
Encoder pulse (differential line driver)	LA	4	When using the encoder output signal (differential line driver system), make it valid in parameter No. 52.	DO-2
	LAR	5		
	LA	6		
	LAR	7		
Override	OVR	2	Apply -10 to +10V across OVR-LG to limit the servo motor speed. 0[%] for -10[V], 100[%] for 0[V], 200[%] for 10[V].	Analog input
External analog torque limit	TLAP	27	Apply 0 to +10V across TLAP-LG to limit the servo motor-generated torque. Zero torque for 0[V], max. torque for 10[V].	Analog input

## 4. ROLL FEEDING SYSTEM

### (2) CN11 (MR-H-D01)

Symbol	Pin No.	Functions and Applications	I/O (Note)
D004	8	Position data common 1 terminal (sign, 6th digit, 5th digit, 4th digit)	
D005	9	Position data common 2 terminal (3rd digit, 2nd digit, 1st digit)	
DI00	10	Position data input terminal (1st digit, 4th digit, 4-bit binary bit 0)	DI-1
DI01	11	Position data input terminal (1st digit, 4th digit, 4-bit binary bit 1)	DI-1
DI02	12	Position data input terminal (1st digit, 4th digit, 4-bit binary bit 2)	DI-1
DI03	13	Position data input terminal (1st digit, 4th digit, 4-bit binary bit 3)	DI-1
DI04	14	Position data input terminal (2nd digit, 5th digit, 4-bit binary bit 0)	DI-1
DI05	15	Position data input terminal (2nd digit, 5th digit, 4-bit binary bit 1)	DI-1
DI06	34	Position data input terminal (2nd digit, 5th digit, 4-bit binary bit 2)	DI-1
DI07	35	Position data input terminal (2nd digit, 5th digit, 4-bit binary bit 3)	DI-1
DI08	36	Position data input terminal (3rd digit, 6th digit, 4-bit binary bit 0)	DI-1
DI09	37	Position data input terminal (3rd digit, 6th digit, 4-bit binary bit 1)	DI-1
DI10	38	Position data input terminal (3rd digit, 6th digit, 4-bit binary bit 2)	DI-1
DI11	39	Position data input terminal (3rd digit, 6th digit, 4-bit binary bit 3)	DI-1
DI16	45	Override selection input terminal	DI-1
DI17	46	Speed selection input terminal, 3-bit binary bit 0	DI-1
DI18	18	Speed selection input terminal, 3-bit binary bit 1	DI-1
DI19	19	Speed selection input terminal, 3-bit binary bit 2	DI-1
DI20	2	Manual pulse generator magnification selection input terminal, 2-bit binary bit 0	DI-1
DI21	3	Manual pulse generator magnification selection input terminal, 2-bit binary bit 1	DI-1
DI22	28	Strobe input terminal (not required when the 6-digit digital switch is used)	DI-1
D000	4	Alarm code output terminal, 4-bit binary bit 0	DO-2
D001	5	Alarm code output terminal, 4-bit binary bit 1	DO-2
D002	6	Alarm code output terminal, 4-bit binary bit 2	DO-2
D003	7	Alarm code output terminal, 4-bit binary bit 3	
VDD	21	24VDC output terminal	
VIND	20	Connect with VDD or connect an external power supply.	
SG	16,17 40,47	Common terminal for 24VDC except position data	
SD	50	Shielding terminal	

### (3) CN12(MR-H-D01/connector for connection of manual pulse generator)



Symbol	Pin No.	Functions and Applications	I/O (Note)
PP1D	5	Open collector forward rotation pulse input terminal	DI-2
PN1D	6	Open collector reverse rotation pulse input terminal	DI-2
P5	7,8	5VDC output terminal	
OP5	9	Connect with P5 or connect an external power supply.	
LG	2,11	5VDC common terminal	
SD	20	Shielding terminal	







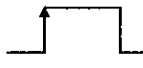
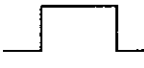
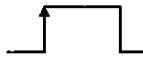

## 4. ROLL FEEDING SYSTEM

### 4.3.3 Control input/output signals

#### (1) Start signals and operation mode select signals

The start signals change as indicated below depending on the operation mode selection conditions.

Indicates that the signal is made valid when it is switched from off to on, and  is invalid if switched on during operation. Indicates that the signal is valid while it is on, and  is made invalid when switched off.

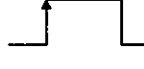
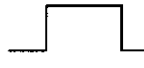
Signal		Operation Mode			
		Automatic	Manual	Remote Manual	
(Note) CN1	Automatic operation	DI0	ON	OFF	OFF
	Manual operation	DI1	OFF	ON	ON
	Remote manual operation	DI2	OFF	OFF	ON
	Forward rotation start	ST1	 (Forward rotation start)	/	 (Forward rotation jog)
	Reverse rotation start	ST2	 (Reverse rotation start)		 (Reverse rotation jog)
	Temporary stop	STP	 (Temporary stop)	 (Temporary stop)	/
JOG	 	/	 (Forward/reverse rotation jog)		
Parameter unit			/	 (1-step feed)	
Manual pulse generator		/		 (Manual pulse generator)	

Note: If you turn on-off DI0/DI1/DI2 during operation in the automatic operation mode, the operation mode cannot be changed. The operation mode is switched to the one specified by DI0, DI1 and DI2 after completion of positioning to the target position.

## 4. ROLL FEEDING SYSTEM

### (2) Start and stop signals

- Make up the sequence so that the start signal is switched on after the main circuit has been set up. The start signal is invalid if it is switched on before the main circuit is set up. Normally, interlock is provided between the start signal and ready signal (RD).
- The controller is started when the external start signal is switched from off to on. The internal processing of the controller delays 3ms maximum. The other signal delays 10ms maximum. (As shown below on the left)

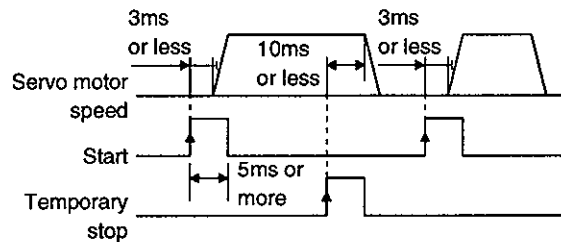

- When the programmable controller is used, the start/stop signal ON time should be 5ms or more to prevent a malfunction.
- The start signal (ST1/ST2) is not accepted during operation. The next operation must be started after the rough match signal has been output with the rough match output range set to zero, or after the in-position signal has been output.

### (3) Restart (DEC)

Turning on the temporary stop (STP) signal to make a stop and then turning on the restart (DEC) signal executes the operation of the remaining feed length.

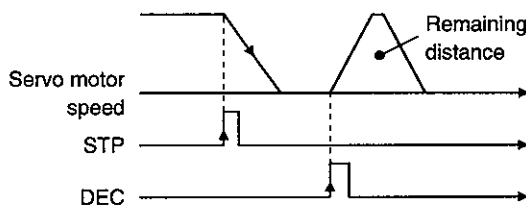

(a) Use of restart signal (DEC)

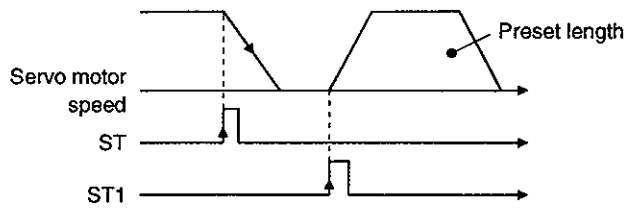

(b) Use of forward rotation start signal (ST1)

### (4) Clear

Switch this signal on after a temporary stop to clear the remaining distance. Switch this signal on during operation to clear the feed command and droop and bring the servo motor to a sudden stop. Do not switch this signal on during high-speed operation, because it will bring the servo motor to a sudden stop, increasing the shock and vibration given to the machine.

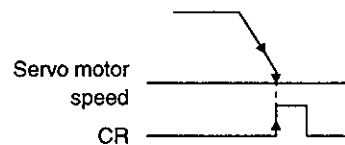
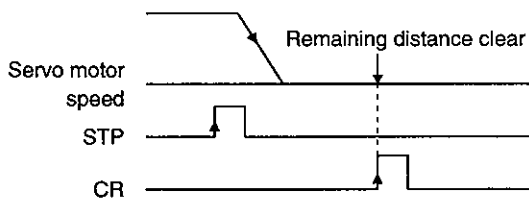

## 4. ROLL FEEDING SYSTEM

### (5) Positioning completion signal (PF)

Switched on when the droop of the deviation counter falls within the preset positioning completion range (parameter No.16). When operation is performed at low speed, the low droop may keep the PF signal on if the positioning completion range (parameter No.16) setting is large.

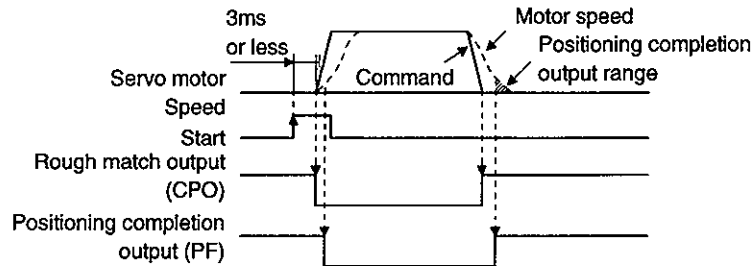

### (6) Rough match (CPO)

Switched on when the command remaining distance falls within the rough match output range (parameter No.17).

### (7) Override

The override (OVR) may be used to change the servo motor speed. The following table lists the signals and parameter related to the override:

Item	Name	Remarks
Analog input signal	Override (OVR)	
Contact input signal	Override selection (DI16)	MR-H-D01 option card used
Parameter	No.24 function selection 5	<input type="checkbox"/> <input type="checkbox"/> <input type="checkbox"/> 1: Override used
	No.47 override offset	-9999 to 9999mV

To use override, make it available by setting 1 in parameter No. 24.

#### (a)Override (OVR)

By applying a voltage (-10 to +10V) to the override (OVR) terminal, change values can be set from outside consecutively. The following graph shows the relationship between the input voltage and the ratio of actual speed to preset speed.

Refer to the following diagram when using the 15V power output (P15R, N15R) of the controller.

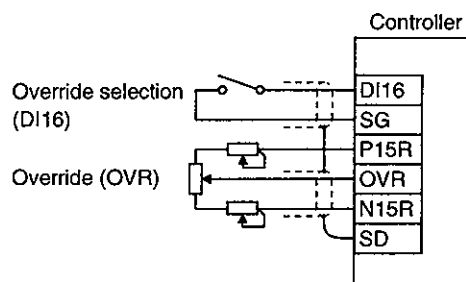
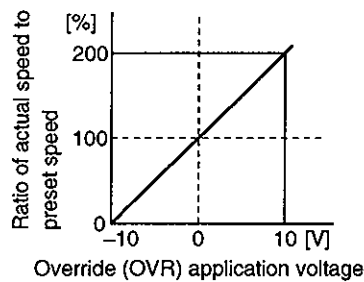

## 4. ROLL FEEDING SYSTEM

### (b) Override selection (DI16)

Select between making override (OVR) Valid and invalid. The MR-H-D01 option card is required to use this signal. Set  $\square\square\square 1$  in parameter No.66 to make override selection valid.

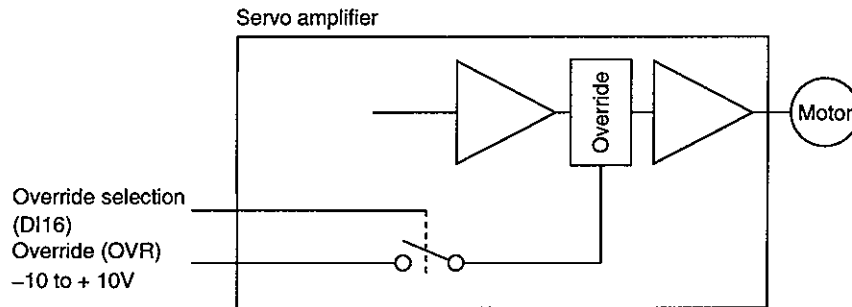

Using the override selection (DI16), choose a change value as follows:

Across DI16-SG	Speed Change Value
Open	No change
Short	Override (OVR) setting is made valid.

### (c) Override offset (parameter No.47)

Using parameter No.47, the offset voltage can be set relative to the input voltage for the override (OVR). The setting is between  $-9999$  to  $9999\text{mV}$ .

### (8) Torque limit

The following table lists the signals and parameters related to the torque limit:

Item	Name	Remarks
Analog input signal	External torque limit (TLAP)	
Contact input signals	Torque limit selection(LSP)	Set $\square 0 \square \square$ (initial value) in parameter No.41
Contact output signal	Limiting torque (CPO)	
Parameters	No.40 internal torque limit	0 to 100%
	No.54 internal torque limit2	0 to 100%
	No.48 torque limit offset	$-9999$ to $9999\text{mV}$
	No.41 input signal selection	Selection of the rotation direction in which torque limit is executed

The torque limit is available in two types: internal torque limit set in parameters and external torque limit using analog input signal. This function limits generated torque on the assumption that the maximum torque of the servo motor is 100%.



## 4. ROLL FEEDING SYSTEM

### (a) Internal torque limits (Parameter No.40, 54)

Use parameter No.40 and 54 to set the internal torque limit values. The following graph shows the generated torque relative to the setting.

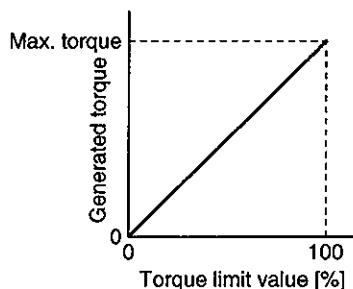

### (b) External torque limit (TLAP)

By applying a voltage (0 to 10V) to the external torque limit (TLAP) terminal, limit values can be set from outside consecutively. The following graph shows the relationship between input voltage and limit value.

Depending on the servo amplifier, the limit value has about 5% variations to the input voltage. As this may not cause torque to be limited sufficiently at less than 0.05V, use this function at the voltage of 0.05V or more.

Refer to the following diagram when using the 15V power output (P15R) of the Controller:

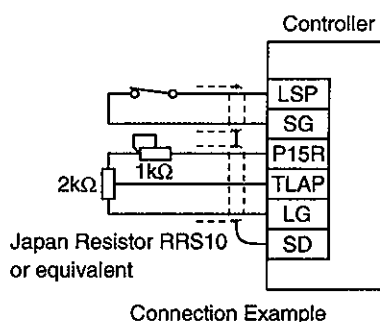
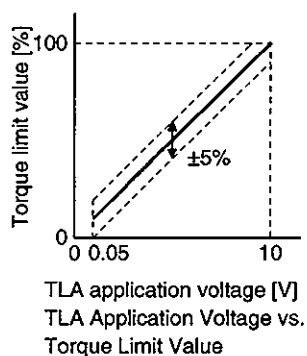

## 4. ROLL FEEDING SYSTEM

### (c) Torque limit selection (LSP)

To use torque limit selection (LSP), set □0□□ in parameter No. 41.

This input signal can be used to choose the torque limit value made valid. When not using torque limit selection (LSP), set □1□□ in parameter No. 41. At this time, the internal torque limit (parameter No. 40) setting is always made valid.

1) When □□0□ (initial value) is set in parameter No. 41

Switched between external torque limit (TLAP) and internal torque limit (parameter No. 40).

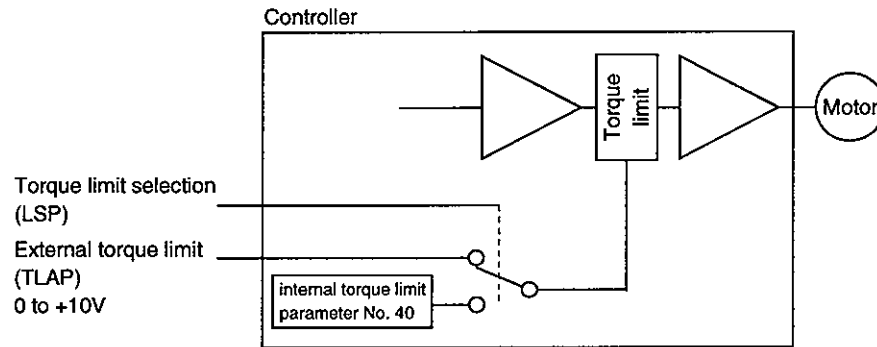

Using the internal torque limit selection (LSP), choose the limit value as follows. When LSD-SG are shorted, the smaller value of the external torque limit and internal torque limit is chosen:

Across LSP-Se	Torque Limit Value
Open	External torque limit (TLAP) if External torque limit (TLAP) < internal torque limit
	Internal torque limit if External torque limit (TLAP) > internal torque limit
Short	Internal torque limit

## 4. ROLL FEEDING SYSTEM

2) When  $\square\square 1\square$  is set in parameter No. 41

Switched between internal torque limit (parameter No. 40) and internal torque limit 2 (parameter No. 54).

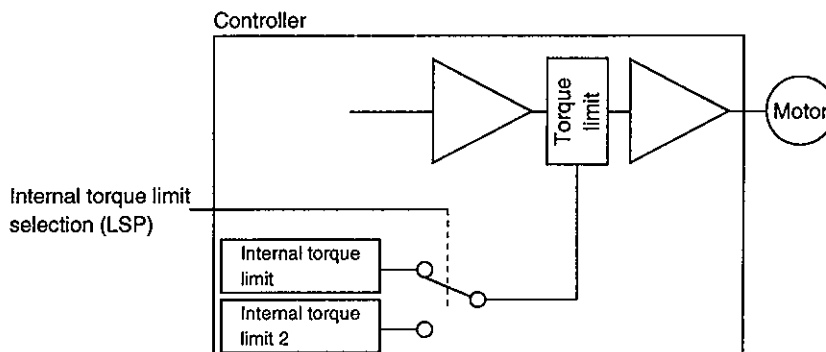

Using the internal torque limit selection (LSD), choose the limit value as follows. When LSD-SG are shorted, the smaller value of the internal torque limit and internal torque limit 2 is chosen:

Across TL2-SG	Torque Limit Value
Open	Internal torque limit
Short	Internal torque limit if internal torque limit < internal torque limit 2
	Internal torque limit 2 if internal torque limit > internal torque limit 2

(9) Stroke ends (LSP,LSN)

Set  $11\square\square$  in parameter No.41 to make these signals valid. Use limit switches or the like with LSP and LSN to connect with SG. On a machine which does not have stroke ends, connect LSP and LSN with SG. If they are not connected, the servo motor will not rotate.

Disconnection of LSP or LSN from SG during rotation of the servo motor (LSP during CCW rotation, LSN during CW rotation) causes the servo motor to be brought to a sudden stop and servo-locked. At this time, the deviation counter is cleared.

(10) Manual pulse generator pulse magnification selection (DI20, DI21)

Use the option card (MR-H-D01)

Set  $\square 4\square\square$  in parameter No.65 to make this signal valid.

Select the pulse magnification across DI20, DI21-SG as indicated in the following table.

Pulse Magnification	DI21	DI20
1 time	OFF	OFF
10 time	OFF	ON
100 time	ON	OFF

(11) Alarm code output (DO00, DO01, DO02, DO03)

Use the option card (MR-H-D01)

Set 1 in parameter No.67 to make this signal valid. The alarm type is output in 4-bit code.

For more information, refer to Section 12.2.

## 4. ROLL FEEDING SYSTEM

### (12) Strobe signal (DI22)

Use the option card (MR-H-D01)

When the programmable controller is used, this signal controls the read timing of position data. Position data is read in two parts separately: lower 3 digits; and upper 3 digits. Hence, the strobe signal must be switched on twice. Provide position data and switch the strobe signal on with a delay of 5ms or more. Keep the strobe signal on for 5ms or more and keep the data unchanged during this period.

The relationship between the position data and start signal (ST1,ST2) should be as shown in the following timing chart. Two or more pieces of position data cannot be read. After one piece of data has been read, switch on the start signal.

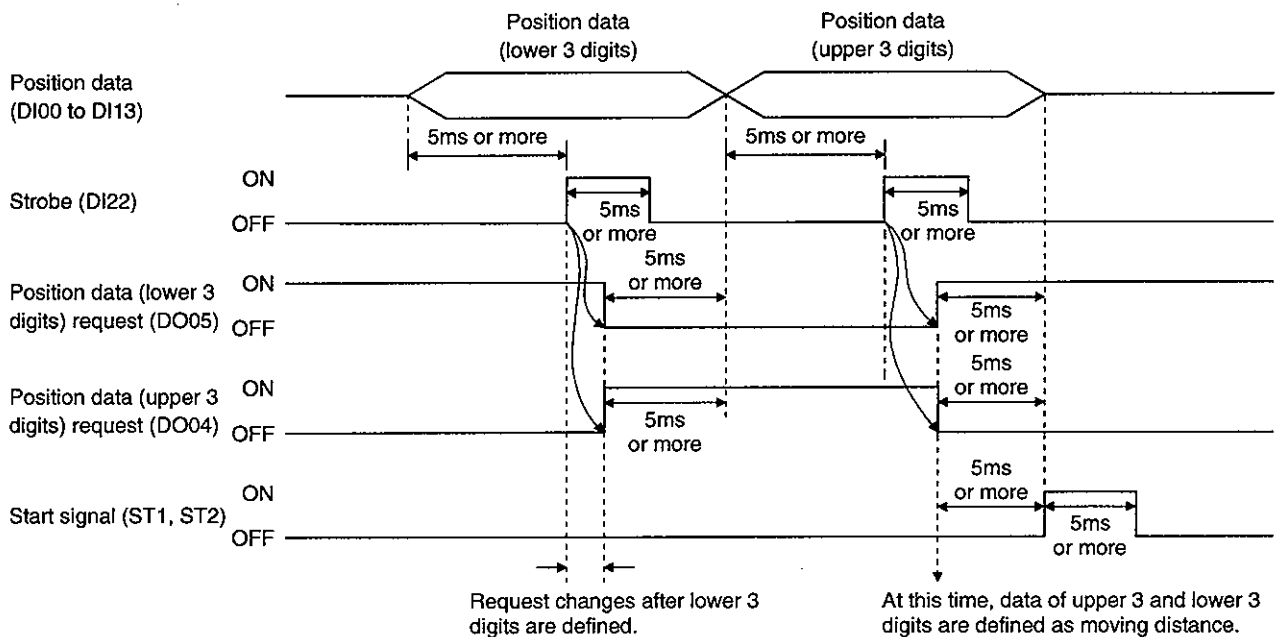

### (13) Speed select signal (DI17, DI18, DI19)

Use the option card (MR-H-D01)

3-bit binary signal used to select the speed block number (No.1 to 8).

Speed Block No.	DI19	DI18	DI17
	bit2 (MSB)	bit1	bit0 (LSB)
1	0	0	0
2	0	0	1
3	0	1	0
4	0	1	1
5	1	0	0
6	1	0	1
7	1	1	0
8	1	1	1

3-bit binary, 0:OFF 1:ON

## 4. ROLL FEEDING SYSTEM

---

### 4.4 OPERATION

#### 4.4.1 When Switching Power On for the First Time

##### (1) Pre-operation checks

Before starting operation, check the following:

##### (a) Wiring

- 1) A correct power supply is connected to the power input terminals (R, S, T) of the controller.
- 2) The servo motor power supply terminals (U, V, W) of the controller match in phase with the power input terminals (U, V, W) of the servo motor.
- 3) The servo motor power supply terminals (U, V, W) of the servo amplifier are not shorted to the power input terminals (R, S, T).
- 4) The controller and servo motor are grounded securely.
- 5) When using the regenerative brake option, twisted cables are used and the lead of the built-in regenerative brake resistor has been removed.
- 6) When stroke end limit switches are used, the signals across LSP-SG and LSN-SG are on during operation.
- 7) 24VDC or higher voltages are not applied to the pins of connectors CN1.
- 8) SD and SG of connectors CN1 are not shorted.
- 9) The wiring cables are free from excessive force.

##### (b) Environment

Signal cables and power cables are not shorted by wire offcuts, metallic dust or the like.

##### (c) Machine

- 1) The screws in the servo motor installation part and shaft-to-machine connection are tight.
- 2) The servo motor and the machine connected with the servo motor can be operated.

## 4. ROLL FEEDING SYSTEM

### 4.4.2 Startup

#### ! WARNING

- Do not operate the switches with wet hands. You may get an electric shock.
- Do not operate the controller with the front cover removed. High-voltage terminals and charging area are exposed and you may get an electric shock.
- During power-on or operation, do not open the front cover. You may get an electric shock.

#### ! CAUTION

- Before starting operation, check the parameters. Some machines may perform unexpected operation.
- During power-on or soon after power-off, do not touch the servo amplifier heat sink, regenerative brake resistor, servo motor, etc. as they may be at high temperatures. You may get burnt.

Connect the servo motor with a machine after confirming that the servo motor operates properly alone. For startup reference, a single machine structure will be described. Refer to this section and start up the machine safely.

#### (1) Machine conditions

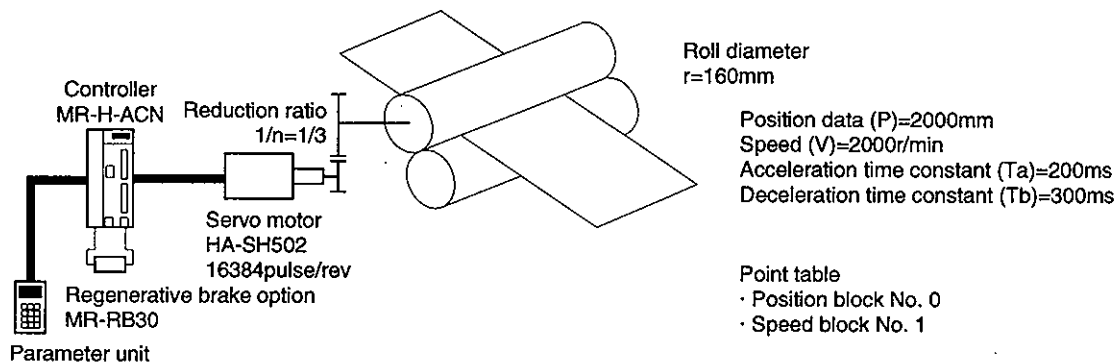

- 1) Absolute position detection system used
- 2) Command resolution: 10 $\mu$ m
- 3) Command system: Roll feeding system
- 4) Electronic gear calculation

$$\frac{\text{CMX (pulse)}}{\text{CDV (\mu m)}} = \frac{16384}{\frac{1}{n} \cdot r \cdot \pi \cdot 1000} = \frac{16384}{\frac{1}{3} \cdot 160 \cdot \pi \cdot 1000} \approx \frac{4096}{41888} = \frac{2048}{20944} \dots\dots\dots(4.1)$$

CMX=2048

CDV=20944

- 5) Position block No.1 is used to execute automatic operation once.

## 4. ROLL FEEDING SYSTEM

### (2) Startup procedure

#### (a) Power on

- 1) Switch off the servo on (SON) signal.
- 2) When main circuit power/control circuit power is switched on, "Position" appears on the parameter unit display.

#### (b) Test operation 1

Using jog operation in the "test operation mode" of the Servo Configuration Software, make sure that the servo motor operates. (Refer to Section 7.2.)

#### (c) Parameter setting

Set the parameters according to the structure and specifications of the machine. Refer to Chapter 6 for the parameter definitions and to Sections 7.2 for the setting method.

Parameter	Name	Setting	Description
No.0	Motor series	0	HA-SH series servo motor used
No.1	Motor type	502	HA-SH502 used
No.2	Feeding system	<input type="checkbox"/> 8 <input type="checkbox"/> 0	Roll feeding system MR-RB032 regenerative brake option is used.
No.3	Function selection 1	0 <input type="checkbox"/> <input type="checkbox"/> 0	Linear acceleration/deceleration system Used in incremental system.
No.4	Function selection 2	<input type="checkbox"/> 001	As command resolution is 10 $\mu$ m, feed length multiplying factor of 10 times is chosen. Position data unit [mm] is selected. Digital display, automatic decimal point setting selection.
No.5	Electronic gear numerator (CMX)	2048	From calculation result of formula (4.1)
No.6	Electronic gear denominator (CDV)	20944	From calculation result of formula (4.1)

After setting the above parameters, switch power off once. Then switch power on again to make the set parameter values valid.

#### (d) Position block setting

Set the position block according to the operation pattern. Refer to Section 4.4.4 for the position block details and to Section 4.5 for the setting method.

Setting of position block No. 0

Position data [ $\times 10^{\text{STM}}$ $\mu$ m]	(Note) M code	Speed block No.
20000		1

Note: Enter no value.

Setting of speed block No. 1

Servo Motor Speed [r/min]	Acceleration Time constant [ms]	Deceleration Time constant [ms]
2000	200	300

## 4. ROLL FEEDING SYSTEM

---

(e) Servo on

Switch the servo on in the following procedure:

- 1) Switch on main circuit/control power.
- 2) Switch on the servo on signal (SON) (short SON-SG).

When placed in the servo-on status, the servo amplifier is ready to operate and the servo motor is locked.

(f) Automatic operation

Set the input signals as listed below and switch on the forward rotation start (ST1) or reverse rotation start (ST2) to execute automatic operation in accordance with point table No. 0.

Signal	Name	ON/OFF	Description
Automatic/manual selection	DI0	ON	Automatic operation selected
Manual operation	DI1	OFF	
Remote manual operation	DI2	OFF	
Servo on	SON	ON	Servo-on status is reached.
Second feed distance	LSN	OFF	Position block No. 0 selected.

(g) Stop

In any of the following statuses, the servo amplifier interrupts and stops the operation of the servo motor:

- 1) Servo on (SON) OFF

The base circuit is shut off and the servo motor coasts.

- 2) Alarm occurrence

When an alarm occurs, the base circuit is shut off and the dynamic brake is operated to bring the servo motor to a sudden stop.

- 3) Emergency stop (EMG) OFF

The base circuit is shut off and the dynamic brake is operated to bring the servo motor to a sudden stop. Alarm A.E6 occurs.



## 4. ROLL FEEDING SYSTEM

### 4.4.3 Manual operation remote mode

For manual operation, set the operation mode selection signals (DI0, DI1, DI2) as listed below:

Operation Mode Selection Signal	ON/OFF
DI0	OFF
DI1	ON
DI2	ON

#### (1) Jog operation

##### (a) Speed setting

Using parameter No. 8 "jog speed 1" and parameter No. 9 "jog speed 2", set the servo motor speeds for jog operation.

Parameter No.	Setting
8	0 to max. speed
9	(r/min)

Choose the jog operation speed with the speed selection signal (JFS). The acceleration/deceleration time constants for jog operation are those of speed block No. 1.

JFS	Setting
OFF	Jog speed 1
ON	Jog speed 2

##### (b) Start

When using the start signal (ST1, ST2), keep the forward rotation start (ST1) or reverse rotation start (ST2) signal on to rotate the servo motor. At this time, the rotation direction is as listed below:

Start Signal	Parameter No. 2			
	□□0□	□□1□	□□2□	□□3□
ST1	CCW (address increase)	CW (address increase)	CCW (address decrease)	CW (address decrease)
ST2	CW (address decrease)	CCW (address decrease)	CW (address increase)	CCW (address increase)

## 4. ROLL FEEDING SYSTEM

(c) Timing chart

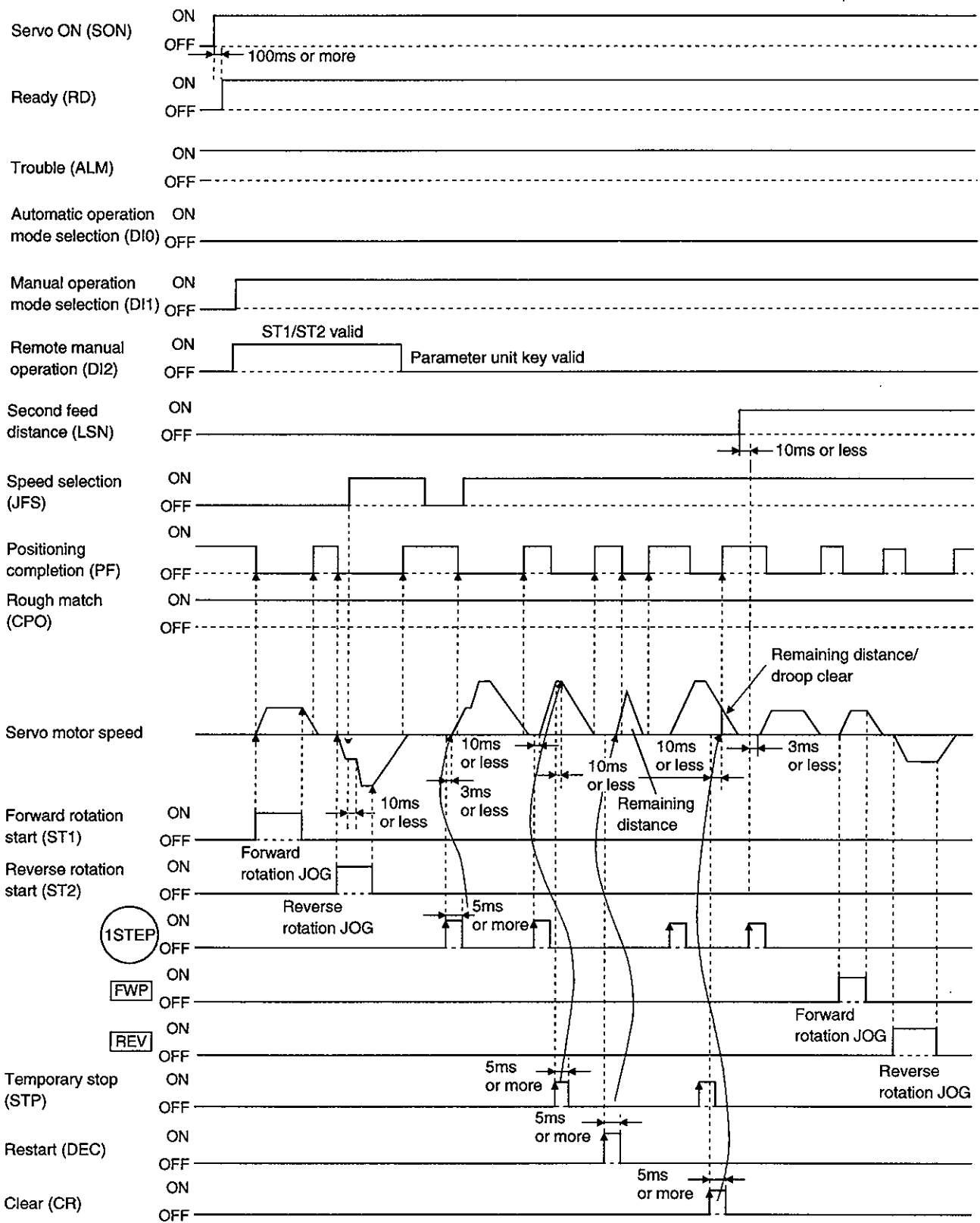

## 4. ROLL FEEDING SYSTEM

### (2) Manual pulse generator operation

#### (a) When option card (MR-H-D01) is not used

Set parameter No. 30 as indicated below to make operation from the manual pulse generator valid. Choose the pulse multiplying factor of the manual pulse generator at this time.

Parameter No. 30  
    \*Machine feedrate per revolution of manual pulse generator in metric system

Setting	Manual Pulse Generator	*Feed Distance/Revolution
0	Not used	
1	Used/pulse 1-time multiplication selected	100 $\mu$ m
2	Used/pulse 10-time multiplication selected	1mm
3	Used/pulse 100-time multiplication selected	10mm

Turn the manual pulse generator (MR-HDP01) to rotate the servo motor. The turning direction of the manual pulse generator corresponds to the rotation direction of the servo motor as listed below:

Turning Direction of Manual Pulse Generator	Parameter No. 2			
	<input type="checkbox"/> <input type="checkbox"/> 0 <input type="checkbox"/>	<input type="checkbox"/> <input type="checkbox"/> 1 <input type="checkbox"/>	<input type="checkbox"/> <input type="checkbox"/> 2 <input type="checkbox"/>	<input type="checkbox"/> <input type="checkbox"/> 3 <input type="checkbox"/>
Forward rotation	CCW (address increase)	CW (address increase)	CCW (address decrease)	CW (address decrease)
Reverse rotation	CW (address decrease)	CCW (address decrease)	CW (address increase)	CCW (address increase)

Manual Pulse Generator

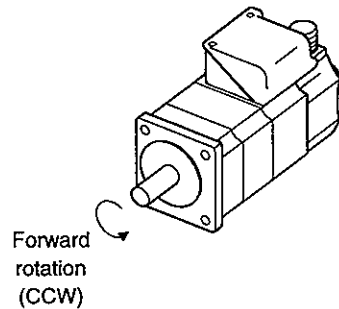
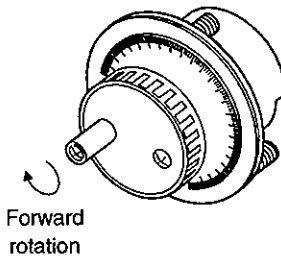

#### (b) When option card (MR-H-D01) is used

The pulse multiplying factor of the manual pulse generator can be changed by using pulse multiplying factor selection in parameter No. 65 and the pulse multiplying factor selection signals (DI20, DI21) of the MR-H-D01. Set parameter No. 65 as listed below to make operation from the manual pulse generator valid.

Parameter No. 65  
    \*Machine feedrate per revolution of manual pulse generator in metric system

Setting	Manual Pulse Generator	*Feed Distance/Revolution
0	Not used	
1	Used/pulse 1-time multiplication selected	100 $\mu$ m
2	Used/pulse 10-time multiplication selected	1mm
3	Used/pulse 100-time multiplication selected	10mm
4	Used/pulse multiplication selected externally	

Set 4 in parameter No. 65 to set the pulse multiplying factor externally. Relationships between the multiplying factors and pulse multiplying factor selection signals are listed below:

Multiplying Factor	Pulse Multiplying Factor Selection Signals	
	DI21	DI20
1 times	OFF	OFF
10 times	OFF	ON
100 times	ON	OFF

## 4. ROLL FEEDING SYSTEM

### 4.4.4 Manual Operation Mode

For manual operation, set the operation mode selection signals (DI0, DI1, DI2) as listed below:

Operation Mode Selection Signal	ON/OFF
DI0	OFF
DI1	ON
DI2	OFF

#### (1) Jog operation

##### (a) Speed setting

Using parameter No. 8 "jog speed 1" and parameter No. 9 "jog speed 2", set the servo motor speeds for jog operation.

Parameter No.	Setting
8	0 to max. speed (r/min)
9	

Choose the jog operation speed with the speed selection signal (JFS). The acceleration/deceleration time constants for jog operation are those of speed block No. 1.

JFS	Setting
OFF	Jog speed 1
ON	Jog speed 2

##### (b) Start

When using the parameter unit, hold down the FWD or REV key of the parameter unit to rotate the servo motor. At this time, the rotation direction is as listed below:

Parameter Unit Key	Parameter No. 2			
	<input type="checkbox"/> <input type="checkbox"/> <input type="checkbox"/> <input type="checkbox"/>	<input type="checkbox"/> <input type="checkbox"/> <input type="checkbox"/>	<input type="checkbox"/> <input type="checkbox"/> <input type="checkbox"/>	<input type="checkbox"/> <input type="checkbox"/> <input type="checkbox"/>
FWD	CCW (address increase)	CW (address increase)	CCW (address decrease)	CW (address decrease)
REV	CW (address decrease)	CCW (address decrease)	CW (address increase)	CCW (address increase)

##### (c) Timing chart

Refer to Section 4.4.3 (1)(c).

#### (2) Stepped operation

Use the second feed distance signal (LSN) to choose the position block No. Press the [1STEP] key of the parameter unit to perform the operation of the position block No. currently being selected.

Position Block No.	Second Feed Distance (LSN)
0	OFF
1	ON

#### (3) Manual pulse generator operation

As in Section 3.4.3 (2).

## 4. ROLL FEEDING SYSTEM

### 4.4.5 Automatic Operation Mode

Set the operation mode select signals (DI0, DI1, DI2) as listed on the right.

Operation Mode Select Signal	ON/OFF
DI0	ON
DI1	OFF
DI2	OFF

#### (1) Roll feeding operation according to point table

##### (a) Setting of position block data

The number of data that may be set is 2 (position block No. s 0 to 1) as standard. Using the second feed distance signal (LSN), select position block No.1.

2-position point data

Position Block No.	Second Feed Distance (LSN)
0	OFF
1	ON

Using the parameter unit, set the position data (increment) in the position block of the position table data. At this time, do not enter any values into the M code and speed block No. items as they are invalid. For the position block setting procedure, refer to Section 3-5.

Position Block No.	Position Data	M Code	Speed Block No.
0	20000		
1	15000		

Position data: Increment of the servo motor

The unit ([mm], [inch]) and input range of the position data (increment) can be changed by setting parameter No.4.

Parameter No. 4

-	-		
---	---	--	--

Set Value (STM)	Input Range (mm or Inch)
0	0 to +999.999
1	0 to +9999.99
2	0 to +99999.9
3	0 to +999999

Set Value	Unit
0	mm
1	inch

## 4. ROLL FEEDING SYSTEM

### (b) Setting of speed block data

By setting parameter No.3, either linear or S-shaped acceleration/deceleration pattern can be selected. The number of speed blocks that may be set is 2 (speed block numbers 1, 2) as standard or 8 (speed block numbers 1 to 8) when the option card (MR-H-D01) is used.

Parameter No. 03

Set Value	Acceleration/Deceleration Pattern
0	Linear acceleration/deceleration
1	S-shaped acceleration/deceleration

For linear acceleration/deceleration pattern, to select the linear acceleration/deceleration pattern, set 0 in parameter No.3.

Speed Block No.	speed (r/min)	Acceleration Time Constant (ms)	Deceleration Time constant (ms)
1	2000	220	20
2	500	100	50
(3)	(1200)	(50)	(55)
⋮	⋮	⋮	⋮
(8)	(1500)	(20)	(30)

For the speed block setting method, refer to Section 4.5.4

Item	Description
Speed	0 to max. speed r/min
Acceleration/Deceleration Time constant	0 to 200000ms The acceleration and deceleration time constants set should be the lengths of time (ms) required for the servo motor to rise to and fall from the rated speed, respectively. (Refer to the chart on the right.)

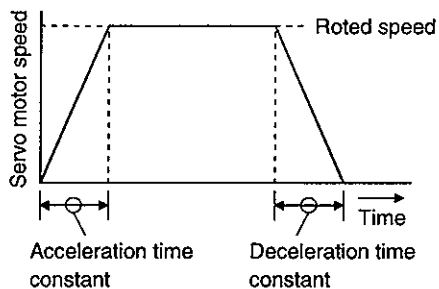

For S-shaped acceleration/deceleration pattern, smooths the rise and fall of servo motor rotation. Set 1 in parameter No.3.

Using the parameter unit, set the servo motor speed, acceleration/deceleration time constant and S-shape time constant in the speed block. The acceleration time constant is equal to the deceleration time constant.

Speed Block No.	Speed (r/min)	Acceleration/Deceleration Time Constant (ms)	S-Shape time constant (ms)
1	2000	1000	100
2	500	1500	200
(3)	(1200)	(1200)	(100)
⋮	⋮	⋮	⋮
(8)	(1500)	(2000)	(200)

## 4. ROLL FEEDING SYSTEM

Item	Description
Speed	0 to max. speed r/min
Acceleration/deceleration time constant	0 to 20000ms
S-shape time	100 to 450ms Set the S-shape time constant to 10-20% of the acceleration/deceleration time constant.

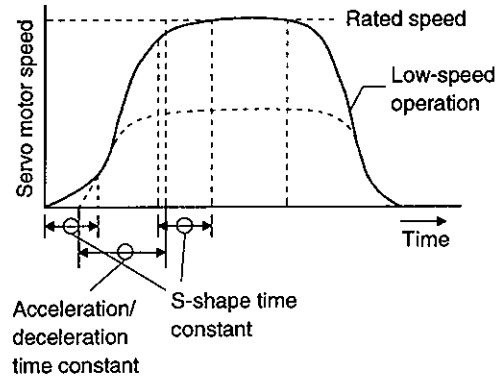

### (c) Operation of the servo motor

When the setting of each point table is complete, select the position block number using the second feed distance signal (LSN). The relationship between the second feed distance signal and position block No.s are listed below:

2-position point data

Position Block No.	Second Feed Distance (LSN)
0	OFF
1	ON

Using the speed select signal, select the speed block number.

Standard (2 speed blocks)

Speed Block No.	Speed Selection (JFS)
1	ON
2	OFF

The relationships between the speed selection signal and speed block No.s are listed below:

MR-H-D01 used (8 speed blocks)

Speed Block No.	DI19	DI18	DI17
	bit2 (MSB)	bit1	bit0 (LSB)
1	0	0	0
2	0	0	1
3	0	1	0
⋮	⋮	⋮	⋮
8	1	1	1

3-bit binary, 0: OFF, 1: ON

## 4. ROLL FEEDING SYSTEM

Switch on the forward rotation start (ST1) or reverse rotation start (ST2) to rotate the servo motor to the preset position. The rotation direction of the servo motor depends on the setting of parameter No.2. The relationship between the set value and servo motor rotation is as listed below:

Parameter No. 2  

-	-		-
---	---	--	---

Set Value	Servo Motor Rotation Direction	
	ST1:ON	ST2:ON
0	CCW rotation (Current value increase)	CW rotation (Current value decrease)
1	CW rotation (Current value increase)	CCW rotation (Current value decrease)
2	CCW rotation (Current value decrease)	CW rotation (Current value increase)
3	CW rotation (Current value decrease)	CCW rotation (Current value increase)

- The following is the timing chart after servo-on.

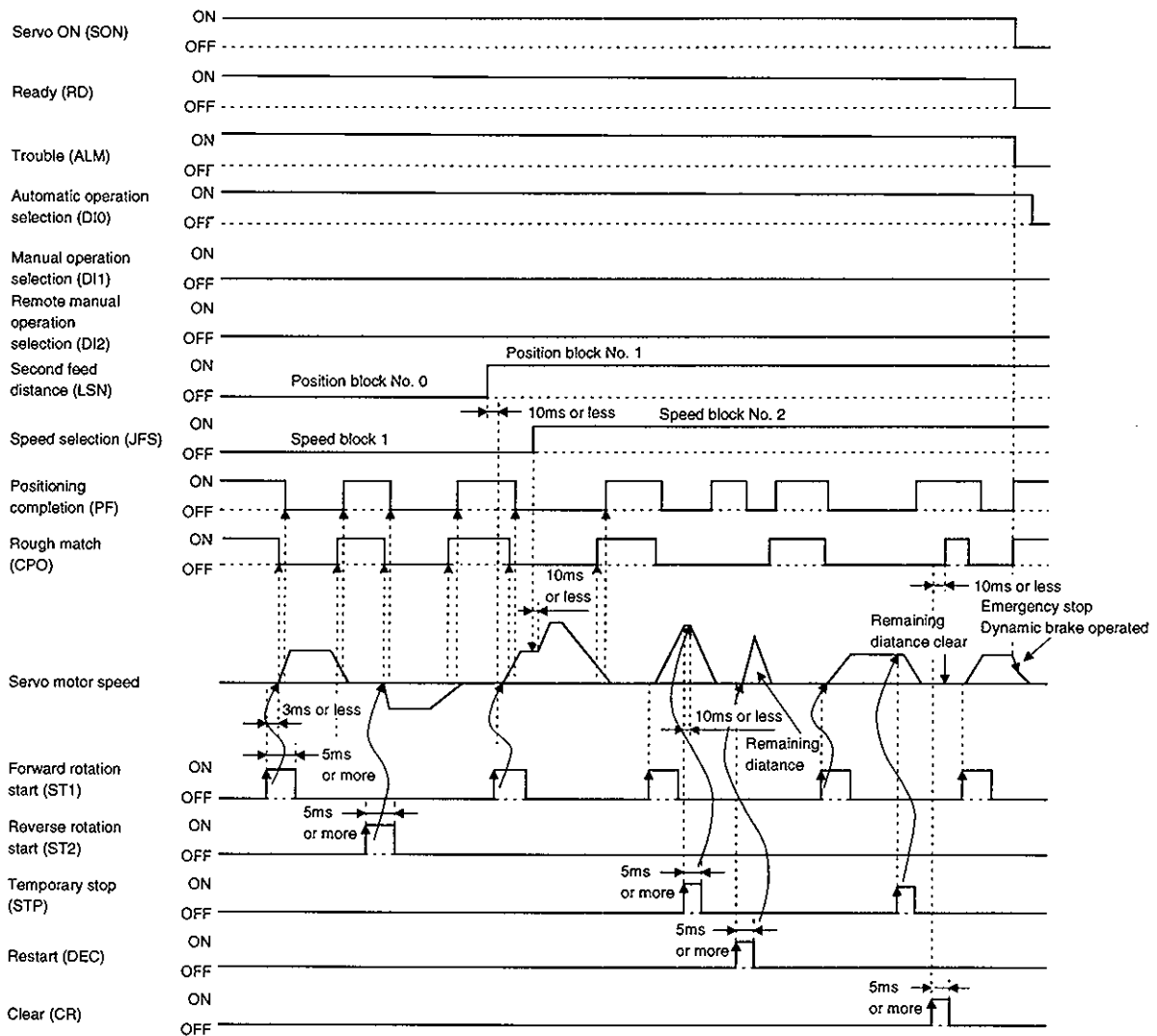



## 4. ROLL FEEDING SYSTEM

### (2) Roll feeding operation under digital switch position command

This operation requires the option card (MR-H-D01) and digital switch (MR-DS60). For wiring, refer to Section 4.2.2

Set 1□11 in parameter No.65.

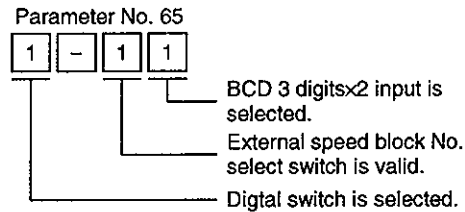

Using the digital switch (MR-DS60), set the position data (increment). The unit ([mm], [[inch]]) and input range of the position data (increment) can be changed by setting parameter No.4.

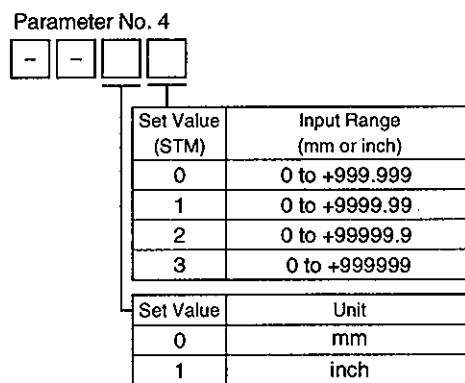

Switch on the forward rotation start (ST1) or reverse rotation start (ST2) to rotate the servo motor to the preset position. Select the speed block as in the above-mentioned absolute command. The rotation direction of the servo motor depends on the setting of parameter No.2, as in (1), this Section.

## 4. ROLL FEEDING SYSTEM

- The following is the timing chart after servo-on.

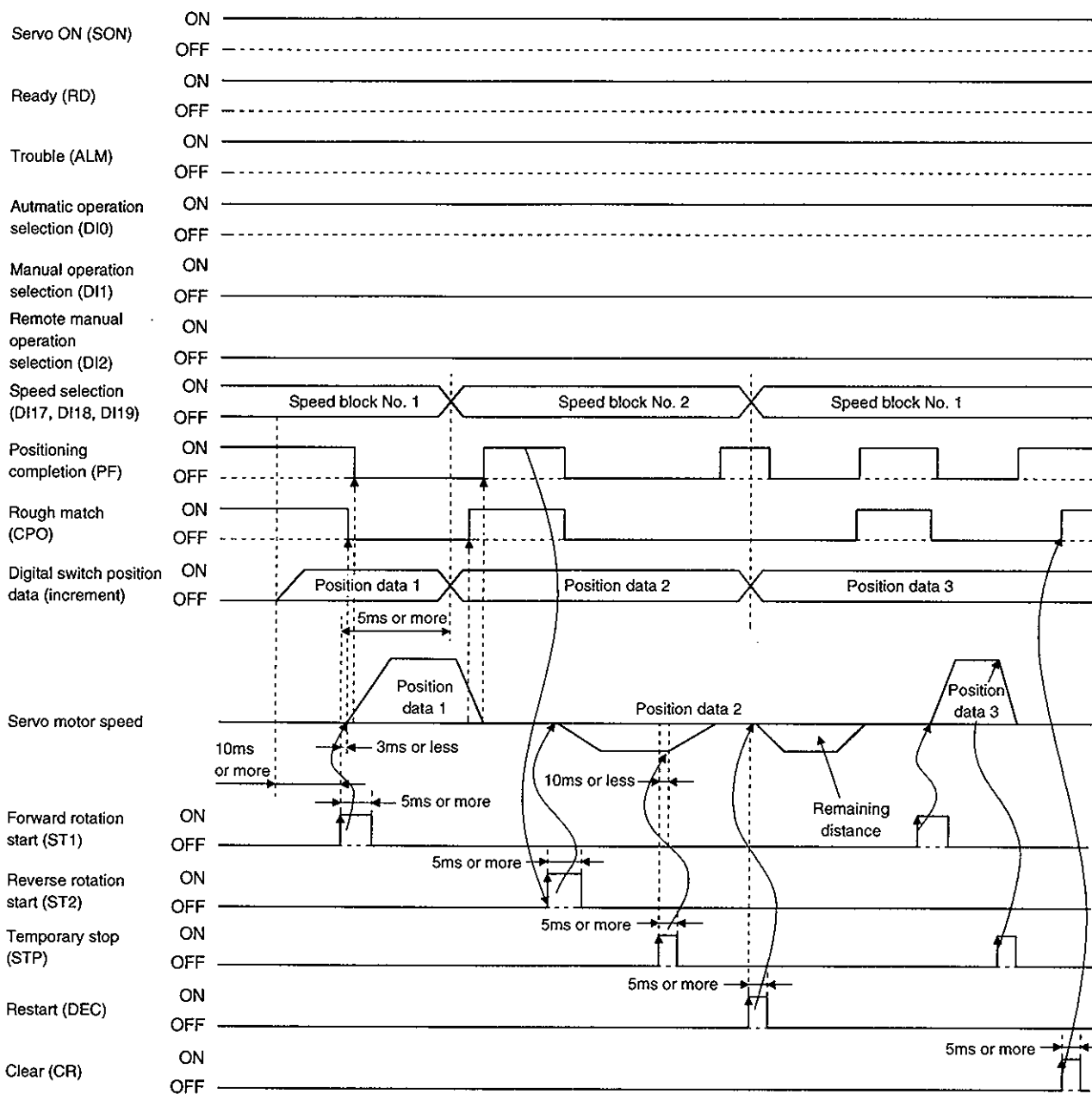

## 4. ROLL FEEDING SYSTEM

---

### (3) Roll feeding operation under programmable controller position command

This operation requires the option card (MR-H-D01). For wiring, refer to Section 3.2.3. The relationship between the position data and strobe signal is as in (13), Section 3.3.3.

Set 0011 in parameter No.65.

Select the input range and speed block number of the position data as in "2) Positioning operation under digital switch position command."

Switch the forward rotation start (ST1) or reverse rotation start (ST2) on to rotate the servo motor to the preset position. For the rotation direction of the servo motor, refer to "c. Operation of the servo motor "in "1) (1), this Section"

# 4. ROLL FEEDING SYSTEM

• The following is the timing chart after servo-on.

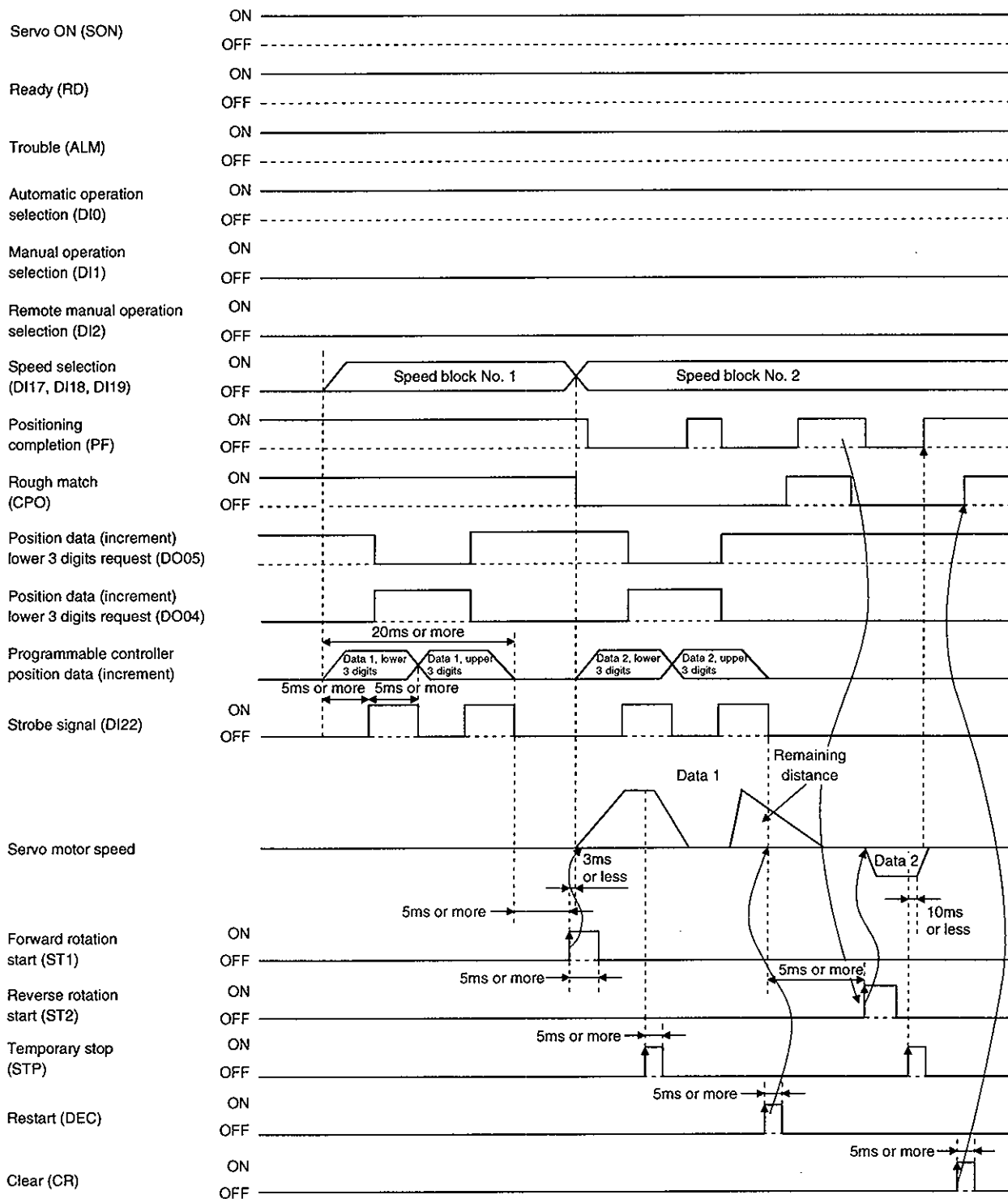

## 4. ROLL FEEDING SYSTEM

### 4.5 Point Table Date Setting Procedures

#### (1) Position block data input

Step	Parameter Unit Operation	Parameter Unit Screen
1)	Press [PARAM/DATA] (call the data setting mode screen). Press [▲] / [▼] to select the block to be set (select the position block). Press [↵] to define the block to be set (define the position block).	<pre> &lt; Set mode &gt; ▲ → Pos. Block Speed Block Edit :HELP ▼                     </pre>
2)	press [0] on the ten-key pad to specify the position block number to be set (for 0). Press [↵] to define the position block number to be set.	<pre> &lt; Pos. set &gt; Block No.       0 Read:↵                     </pre>
3)	If the key press is wrong, press [STOP/RESET] to return to step 2).	<pre> &lt; Pos. set &gt; Block No.       300 Error :RST                     </pre>
4)	press [▲] / [▼] to specify the position block number to be set (for 0). Press [↵] to define the position block number to be set.	<pre> 0→ 12345.0 1→ 78901.2                     </pre>
5)	Press [▲] / [▼] to select the data field into which data is to be input (select the position data). Press [↵] to define the data field into which data is to be input (define the position data).	<pre> 0 Pos.Bloc ▲ → Pos. 12345.6 M code Speed No ▼                     </pre>
6)	Press [D7], [E8], [ISTEP ·] and [F9] on the ten-key pad to enter position data (for 78.9). Press [↵] to write the position data and press [CAN] to return to step 1).  <div style="border: 1px solid black; padding: 2px; display: inline-block;">Position block input complete</div> press [CAN] twice to return to step 4).	<pre> 0 Position ▲ 12345.6       78.9 Write:↵ mm ▼                     </pre>
7)	If the key pressed is wrong, press [STOP/RESET] to return to step 6), or press [CAN] to return to step 5).	<pre> 0 Position ▲ 12345.6 Error :RST ▼                     </pre>

## 4. ROLL FEEDING SYSTEM

### (2) Speed block data input

Step	Parameter Unit Operation	Parameter Unit Screen
1)	Press [PARAM/DATA] (call the data setting screen). Press [▲] / [▼] to select the block to be set (select the speed block). Press [↵] to define the block to be set.	<pre>&lt;Set mode&gt; ▲ Pos. Block →Speed Block Edit :HELP ▼</pre>
2)	Press [1] on the ten-key pad to specify the speed block number to be set (for 1). Press [↵] to define the speed block number to be set.	<pre>&lt;Speed. set &gt; Block No.       1 Read:↵</pre>
3)	If the key pressed is wrong, press [STOP/RESET] to return to step 2).	<pre>&lt;Speed. set &gt; Block No.       9 Error :RST</pre>
4)	Press [▲] / [▼] to specify the speed block number to be set (for 1). Press [↵] to define the speed block number to be set.	<pre>1→ 2000.0 ▲ 2→ 1000.0 3→ 3000.0 4→ 0.0 ▼</pre>
5)	On the data list screen, press [▲] / [▼] to select the data field into which data is to be input (select the speed). Press [↵] to define the data field into which data is to be input (define the speed).	<pre>1 SpeedBlock ▲ →Speed 2000.0 Acc 20000 Dec 20000 ▼</pre>
6)	On the input screen, press [3] [0] [0] [0] on the ten-key pad to enter the speed (for 3000r/min). Press [↵] to write the speed and press [CAN] to proceed to step 7).	<pre>1 Ref.Speed ▲ 2000.0 3000.0 Write:↵ r/min ▼</pre>
7)	On the data list screen, press [▲] / [▼] to select the data field into which data is to be input (select the acceleration time constant). Press [↵] to define the data field into which data is to be input (define the acceleration time constant).	<pre>1 SpeedBlock ▲ Speed 3000.0 →Acc 20000 Dec 20000 ▼</pre>
8)	On the input screen, press [1] [A4] [B5] [C6] [D7] on the ten-key pad to enter the acceleration time constant (for 14567m). Press [↵] to write the acceleration time constant and press [CAN] to proceed to step 9).	<pre>1 Acc time ▲ 20000 14567 Write:↵ msec ▼</pre>
9)	On the data list screen, press [▲] / [▼] to select the data field into which data is to be input (select the deceleration time constant). Press [↵] to define the data field into which data is to be input (define the deceleration time constant).	<pre>1 SpeedBlock ▲ Speed 3000.0 Acc 14567 →Dec 10000 ▼</pre>
10)	On the input screen, press [1] [A4] [B5] [C6] [D7] on the ten-key pad to enter the deceleration time constant (for 14567m). Press [↵] to write the deceleration time constant. Speed block input complete. Press [CAN] twice to return to step 4).	<pre>1 Dec time ▲ 10000 14567 Write:↵ msec ▼</pre>
11)	If the key pressed is wrong, press [STOP/RESET] to return to the input screen, or press [CAN] to return to the data list screen.	<pre>1 Dec time ▲ 20000 99999 Error :RST ▼</pre>

## 4. ROLL FEEDING SYSTEM

### (3) Data copy

This function reads the point table data (position blocks, speed blocks) of the MR-H-ACN to the parameter unit and writes them from the parameter unit. By using this function, data can be read once to the parameter unit and then copied to the other MR-H-ACN.

#### (a) Data read

Reads data from the MR-H-ACN to the parameter unit.

Step	Parameter Unit Operation	Parameter Unit Screen
1)	Press [PARAM/DATA]. Press [SHIFT] [3] (position data copy initial screen). Press [CAN] to return to the previous screen.	<pre>           &lt;Set mode&gt; ▲           → Pos. Block            Speed Block           Edit :HELP ▼           </pre>
2)	Press [▲] / [▼] to specify the mode (specify). Press [↵] to define the mode. If the key press is wrong, press [STOP/RESET] or [CAN] to return to step 1).	<pre>           &lt;DATA COPY&gt; ▲           → READ            WRITE            COMPARE ▼            &lt;DATA COPY&gt;           Read ?            Yes: ↵            No: RST           </pre>
3)	Read complete Press [CAN] to return to step 1).	<pre>           &lt;DATA COPY&gt;            COMPLETE           Mode sel.:CAN           </pre>

## 4. ROLL FEEDING SYSTEM

### (b) Data verify

Verifies the data in the parameter unit with that in the MR-H-ACN.

Step	Parameter Unit Operation	Parameter Unit Screen
1)	Press [PARAM/DATA]. Press [SHIFT] [3] (position data copy initial screen). Press [CAN] to return to the previous screen.	<div style="border: 1px solid black; padding: 5px;">           &lt;Set mode&gt; ▲            → Pos. Block            Speed Block            Edit :HELP ▼         </div>
2)	Press [▲] / [▼] to specify the mode (specify). Press [-J] to define the mode.	<div style="border: 1px solid black; padding: 5px;">           &lt;DATA COPY&gt; ▲            → READ            WRITE            COMPARE ▼         </div> <div style="border: 1px solid black; padding: 5px;">           &lt;DATA COPY&gt;  <b>Comparing</b>            Not Power Off         </div>
3)	<b>Verify complete</b> Press [CAN] to return to step 1).	<div style="border: 1px solid black; padding: 5px;">           &lt;DATA COPY&gt;  <b>COMPLETE</b>            Mode sel.:CAN         </div>
4)	<b>When incorrect data exists in the data verified</b> Press [SHIFT] to check incorrect data numbers. <b>When incorrect data overflows a single screen, press [▲] / [▼] to switch to the preceding/next screen.</b> Press [CAN] to return to step 1)	<div style="border: 1px solid black; padding: 5px;">           &lt;DATA COPY&gt;  <b>Compare Er.</b>            Error No. :SFT            Mode sel.:CAN         </div> <div style="border: 1px solid black; padding: 5px;"> <b>Er. Data No.</b> ▲            P010P P010S            P050M P185M            P185S S002V ▼         </div>

### Error number make-up



Data item  
 Block number  
 Data block identification  
 P: Position block  
 S: Speed block

	Position Block	Speed Block
P	Position	V Speed
M	M code	A Acceleration time constant
S	Speed number	D Deceleration time constant
		S S-shape time constant



## 4. ROLL FEEDING SYSTEM

### (c) Data write

Writes the data in the parameter unit to the MR-H-ACN.

Step	Parameter Unit Operation	Parameter Unit Screen
1)	Press [PARAM/DATA]. Press [SHIFT] [3] (position data copy initial screen). Press [CAN] to return to the previous screen.	<pre> &lt;Set mode&gt; ▲ → Pos. Block Speed Block Edit :HELP ▼                     </pre>
2)	Press [▲] / [▼] to specify the mode (specify). Press [↵] to define the mode.	<pre> &lt;DATA COPY&gt; ▲ → READ WRITE COMPARE ▼                     </pre>
3)	When write is inhibited Press [CAN] to return to step 1).	<pre> &lt;DATA COPY&gt; Write Inhibit SON,ALM Press "CAN"                     </pre>
4)	Press [↵] to execute write. Press [STOP/RESET] to stop write and return to step 1).	<pre> &lt;DATA COPY&gt; Write ? Yes:↵ No:RST                     </pre> <pre> &lt;DATA COPY&gt; Writeing Not Power Off                     </pre>
5)	<b>Write complete</b> Press [CAN] to return to step 1).	<pre> &lt;DATA COPY&gt; COMPLETE →Power Off                     </pre>
6)	<b>When incorrect data exists in the data written</b> 1. Press [↵] to write only the correct data. 2. Press [STOP/RESET] to stop write and return to step 1). 3. Press [SHIFT] to check incorrect data numbers. When incorrect data overflows a single screen, press [▲] / [▼] to switch to the preceding/next screen.	<pre> ErrorNo.:SFT Right Data Write Yes:↵ No:RST                     </pre> <pre> Wrong Data ▲ P000P P001P S001V S001A S101D S002V ▼                     </pre> <p style="text-align: center;">[SHIFT]</p>

### Error number make-up

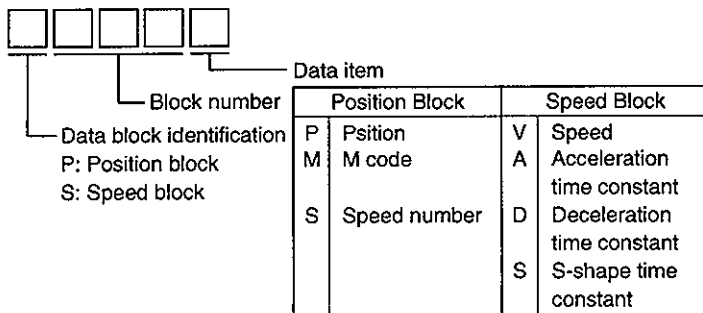

## 4. ROLL FEEDING SYSTEM

### (4) Point table data edition

#### (a) Position block data insertion

Inserts data into the specified position block on a block basis.

Step	Parameter Unit Operation	Parameter Unit Screen
1)	Press [PARAM/DATA]. Press [HELP] (position block edition initial screen). Press [CAN] to return to the previous screen.	<pre> &lt;Set mode&gt; ▲ →Pos. Block Speed Block Edit :HELP ▼                     </pre>
2)	Press [▲]/[▼] to specify the mode (specify). Press [↵] to define the mode (define).	<pre> &lt;Pos. Edit&gt; ▲ →INSERT DELETE ▼                     </pre>
3)	Press [0] on the ten-key pad to specify the block number into which data is to be inserted (for No.0). Press [↵] to execute insertion.	<pre> &lt;Block Ins.&gt; Block No. 0 Yes:↵ No:RST                     </pre>
4)	<b>During insertion</b> Data in block No.0 is shifted to No1 and No.0 is vacated. On completion of insertion, the positioning address list screen is displayed.	<pre> &lt;Block Ins.&gt; Inserting Not Power Off  0→ 0.0 ▲ 1 78901.2 ▼                     </pre>
5)	<b>When insertion cannot be performed (outside the block number setting range)</b> Press [STOP/RESET] to return to step 3).	<pre> &lt;Block Ins.&gt; Block No. 2 Error:RST                     </pre>
6)	<b>When the data of the last block will be deleted by executing insertion</b> Press [STOP/RESET] to return to step 3. Press [↵] to execute insertion.	<pre> &lt;Block Ins.&gt; No. 1 Delete Yes:↵ No:RST                     </pre>

## 4. ROLL FEEDING SYSTEM

### (b) Position block data deletion

Deletes the position data of the specified position block number.

Step	Parameter Unit Operation	Parameter Unit Screen
1)	Press [PARAM/DATA]. Press [HELP] (position block edition initial screen). Press [CAN] to return to the previous screen.	<pre> &lt;Set mode&gt; ▲ → Pos. Block Speed Block Edit :HELP ▼           </pre>
2)	Press [▲] / [▼] to specify the mode (specify). Press [↵] to define the mode (define).	<pre> &lt;Pos. Edit&gt; ▲ INSERT →DELETE ▼           </pre>
3)	Press [0] on the ten-key pad to specify the block number from which data is to be deleted (for No.0). Press [↵] to execute deletion	<pre> &lt;Block Del.&gt; Block No. 0 Yes:↵ No:RST           </pre>
4)	<b>During deletion</b> Data in block No.0 is deleted, the data in No.1 is shifted to No.0, and No.1 is vacated. On completion of deletion, the positioning address list screen is displayed.	<pre> &lt;Block Del.&gt; Deleting Not Power Off  0→ 3000.0 ▲ 1 0.0 ▼           </pre>
5)	<b>When deletion cannot be performed (outside the block number setting range)</b> Press [STOP/RESET] to return to step 3).	<pre> &lt;Block Del.&gt; Block No. 2 Error:RST           </pre>

## 5. SIGNALS AND WIRING

### 5. SIGNALS AND WIRINGS



**WARNING**

- Any person who is involved in wiring should be fully competent to do the work.
- Before starting wiring, make sure that the voltage is safe in the tester more than 10 minutes after power-off. Otherwise, you may get an electric shock.
- Ground the controller and the servo motor securely.
- Do not attempt to wire the controller and servo motor until they have been installed. Otherwise, you may get an electric shock.
- The cables should not be damaged, stressed excessively, loaded heavily, or pinched. Otherwise, you may get an electric shock.



**CAUTION**

- Wire the equipment correctly and securely. Otherwise, the servo motor may misoperate..
- Connect cables to correct terminals to prevent a burst, fault, etc.
- Ensure that polarity (+, -) is correct. Otherwise, a burst, damage, etc. may occur.
- The surge absorbing diode installed to the DC relay designed for control output should be fitted in the specified direction. Otherwise, the signal is not output due to a fault, disabling the emergency stop and other protective circuits.

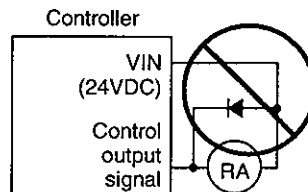

- Use a noise filter, etc. to minimize the influence of electromagnetic interference, which may be given to electronic equipment used near the controller.
- Do not install a power capacitor, surge suppressor or radio noise filter (FR-BIF option) with the power line of the servo motor.
- When using the regenerative brake resistor, switch power off with the alarm signal. Otherwise, a transistor fault or the like may overheat the regenerative brake resistor, causing a fire.
- Do not modify the equipment.

## 5. SIGNALS AND WIRING

### 5.1 Internal Connection Diagram of Servo Amplifier

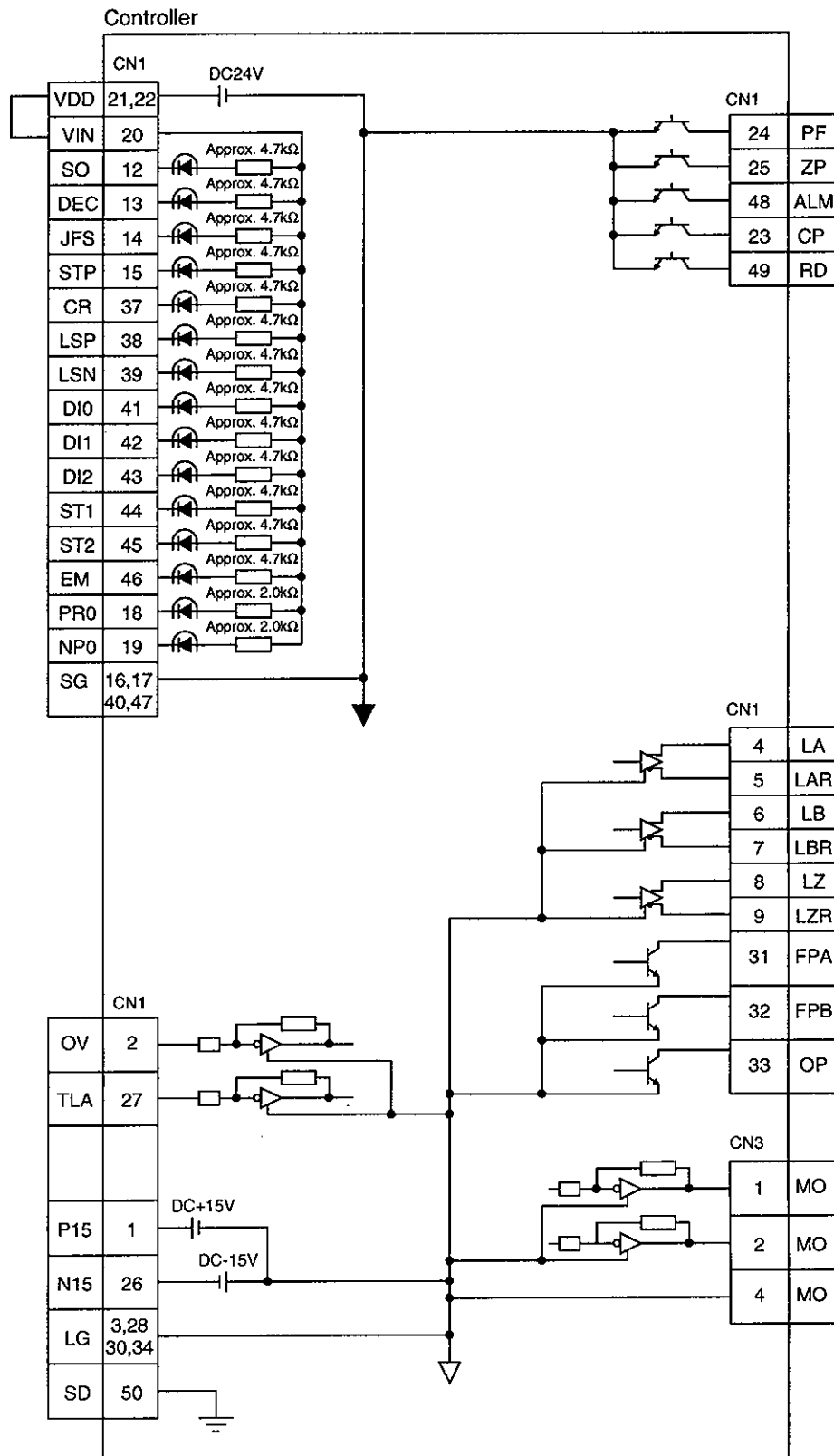

# 5. SIGNALS AND WIRING

## 5.2 Interfaces

### 5.2.1 Common line

<b>POINT</b>
<ul style="list-style-type: none"> <li>• Do not connect SG, LG and SD externally.</li> </ul>

The following diagram shows the power supply and its common line.

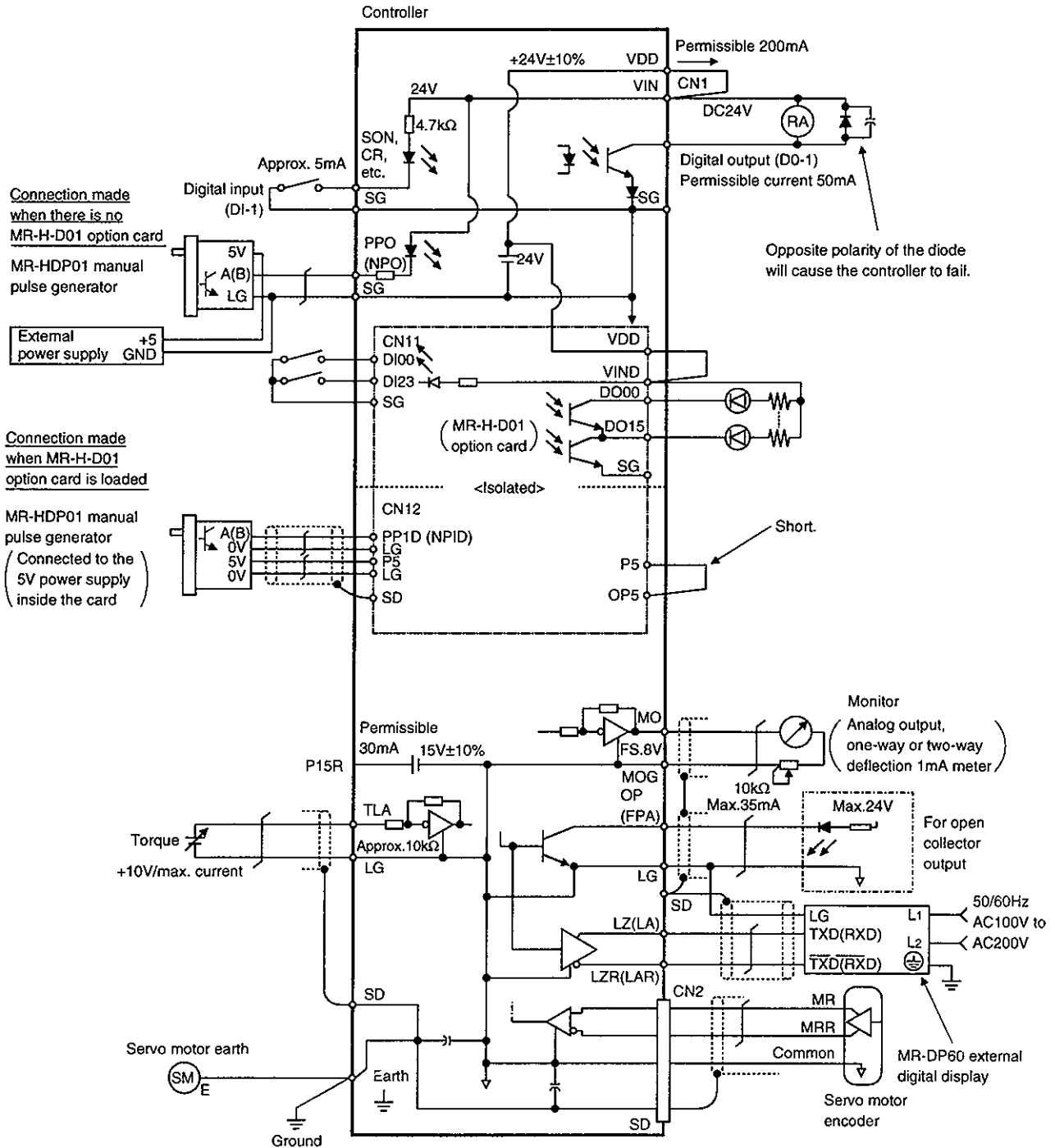

## 5. SIGNALS AND WIRING

### 5.2.2 Detailed description of the interfaces

This section gives the details of the I/O signal interfaces (refer to I/O Division in the table) indicated in Sections 3.3.2 or Sections 4.3.2.

Refer to this section and connect the interfaces with the external equipment.

#### (1) Digital input interface DI-1

Give a signal with a relay or open collector transistor.

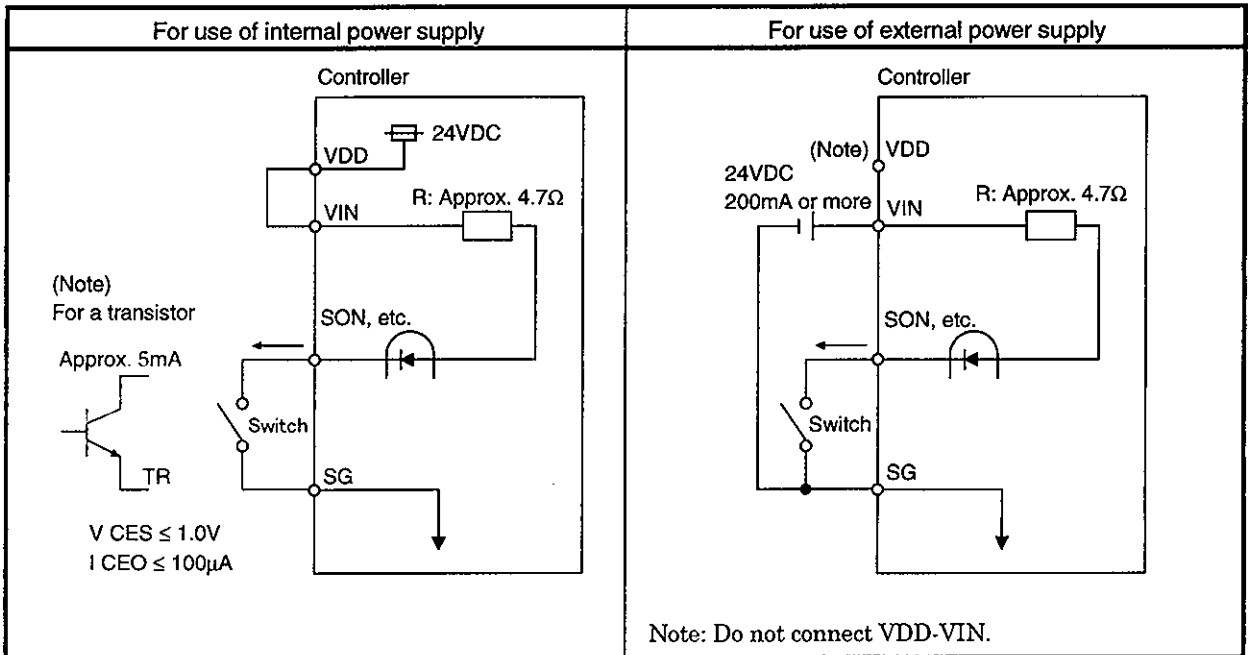

Note: This also applies to the use of the external power supply.

#### (2) Digital output interface DO-1

A lamp, relay or photocoupler can be driven. Provide a diode (D) for an inductive load, or an inrush current suppressing resistor (R) for a lamp load. (Permissible current: 40mA or less, inrush current: 100mA or less)

##### 1) Inductive load

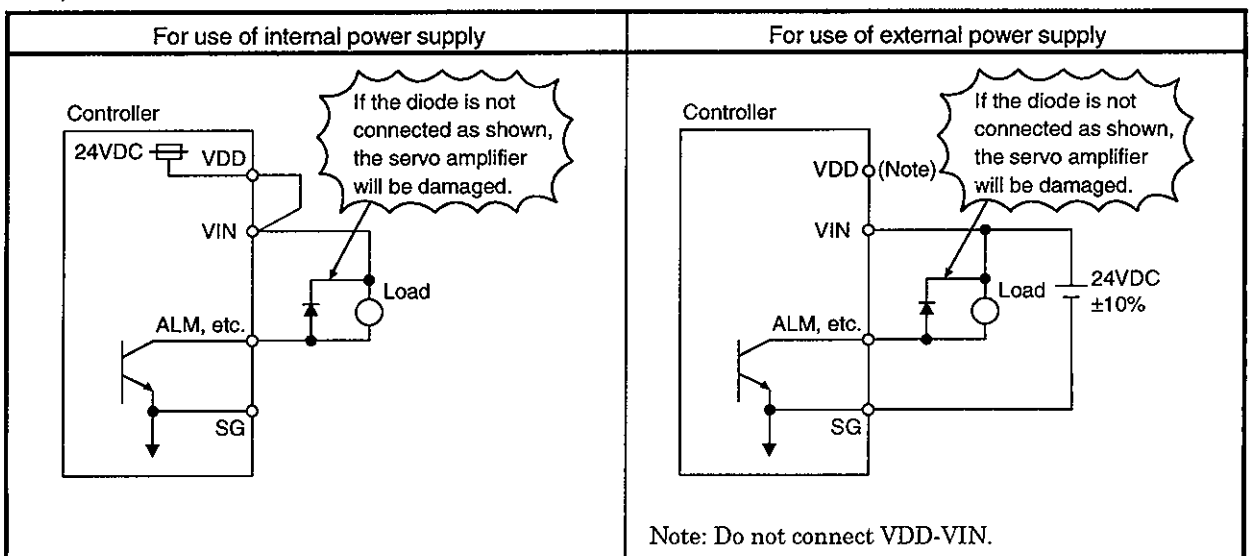

## 5. SIGNALS AND WIRING

### 2) Lamp load

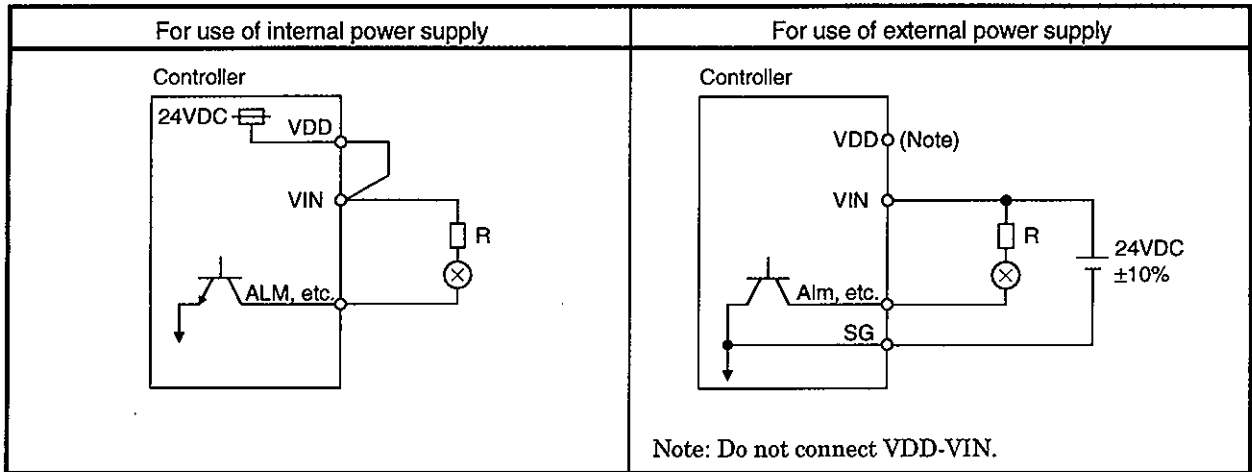

### (3) Manual pulse generator input interface DI-2

Provide a pulse train signal in the open collector system.

#### (a) Open collector system

##### 1) Interface

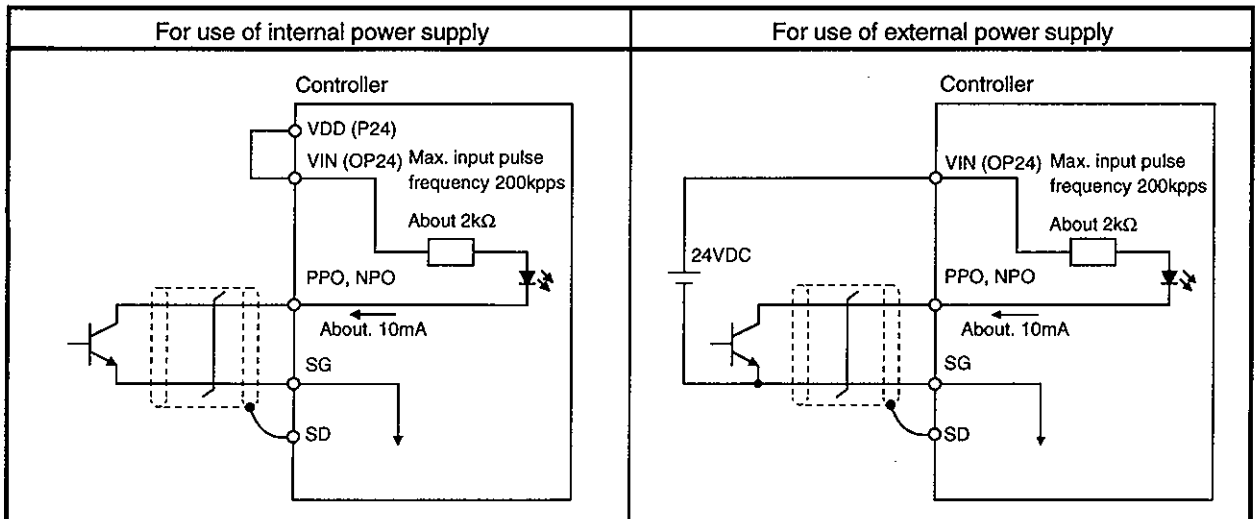

##### 2) Conditions of the input pulse

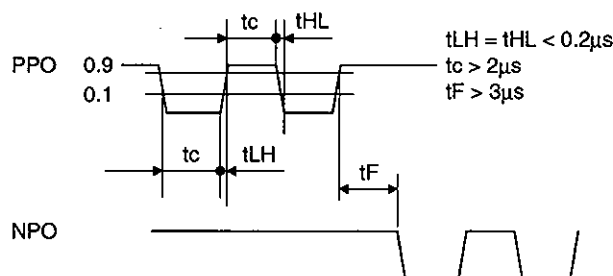



## 5. SIGNALS AND WIRING

### (4) Encoder pulse output DO-2

#### (a) Open collector system

##### 1) Interface

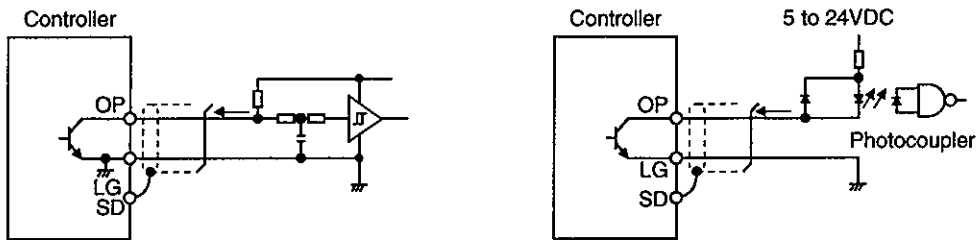

##### 2) Output pulse

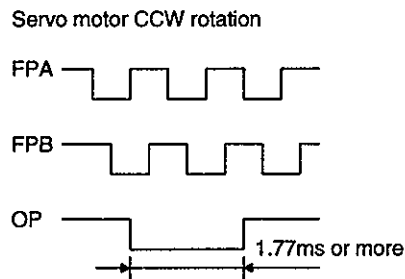

#### (b) Differential line driver system

##### 1) Interface

Max. output current: 35mA

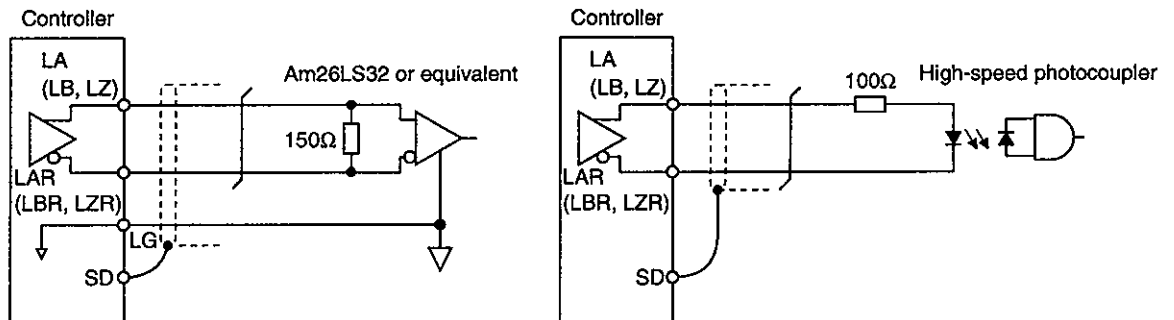

##### 2) Output pulse

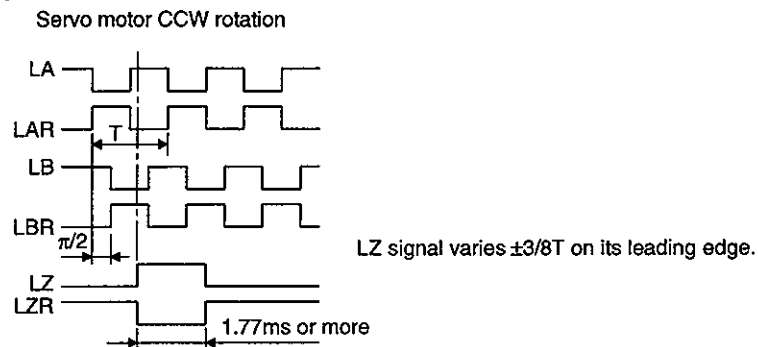

## 5. SIGNALS AND WIRING

### (5) Analog input

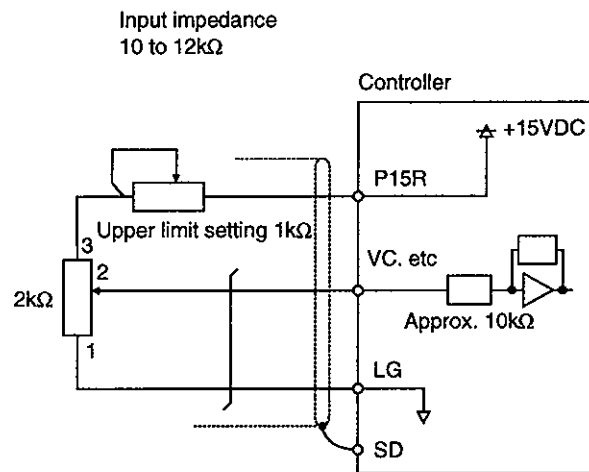

### (6) Analog output

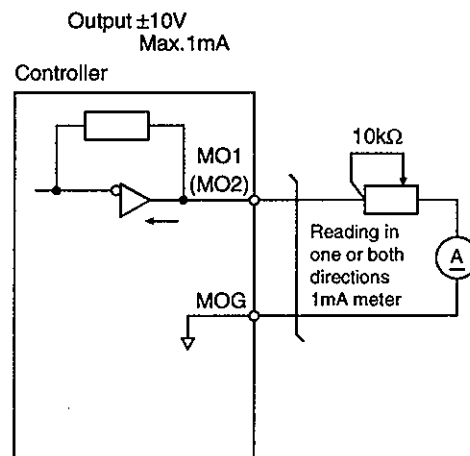

## 5. SIGNALS AND WIRING

### 5.3 Power Line Circuit



#### CAUTION

- When the controller has become faulty, switch power off on the controller power side. Continuous flow of a large current may cause a fire.
- Use the trouble signal to switch power off. Otherwise, a regenerative brake transistor fault or the like may overheat the regenerative brake resistor, causing a fire.

#### 5.3.1 Connection example

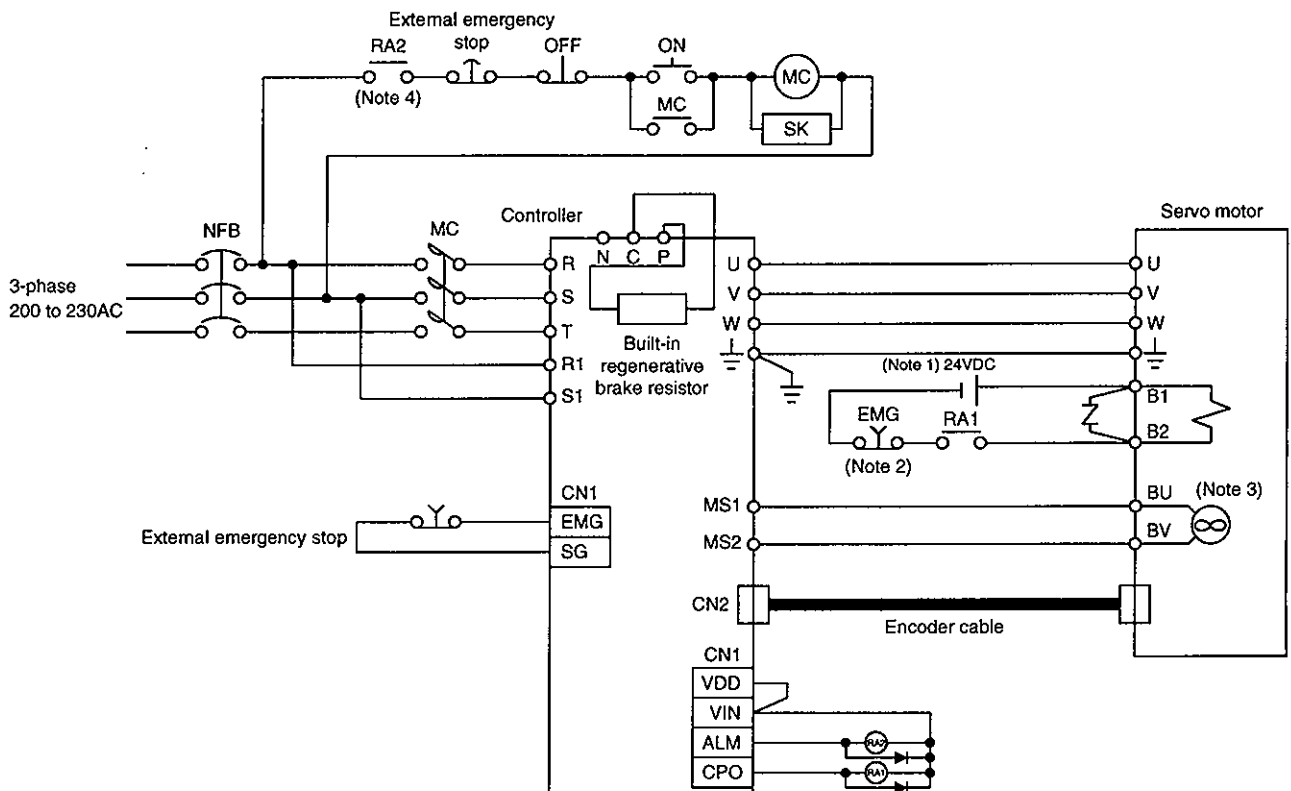

- Note: 1. The interface 24VDC power supply (VDD) of the servo amplifier cannot be used. Always prepare a power supply dedicated to electromagnetic brake. The power supply connected to the lead (blue) of the electromagnetic brake should be wired independently of polarity.
2. When the usage is as described in Section 5.5.2 (2), do not connect the EMG switch.
3. For HA-LH11K2 or more.
4. Configure up a power circuit which will switch off the magnetic contactor after detection of an alarm.

## 5. SIGNALS AND WIRING

### 5.3.2 Terminal

The arrangement and signal layout of the terminal block change with the controller capacity. Refer to Section 13.2.1.

Symbol	Signal	Description
R · S · T	Main circuit power supply	Main circuit power input terminals Connect a three-phase 200 to 230VAC, 50/60Hz power supply to R, S, T. For MR-H700ACN-UE or more, the voltage of 50Hz power is 200 to 220V.
U, V, W	Servo motor output	Servo motor power output terminals Connect to the servo motor power supply terminals (U, V, W).
R1 · S1	Control circuit power supply	Control circuit power input terminals L11 and L21 should be in phase with L1 and L2, respectively. Connect a single-phase 200 to 230VAC, 50/60Hz power supply. For MR-H700ACN or more, the voltage of 50Hz power is 200 to 220V.
P, C, D	Regenerative brake	Regenerative brake option connection terminals The MR-H400ACN to MR-H700ACN are factory-connected with a built-in regenerative brake resistor. When using the regenerative brake option, brake unit or power return converter, always connect it after removing the wiring of the built-in regenerative brake resistor connected across P-C. For MR-H11KACN or more, always connect the supplied regenerative brake resistor across P-C.
MS1 · MS2	Servo motor fan	Servo motor fan power supply terminals Connect to the cooling fan which is built in the HA-LH11K2 to HA-LH22K2 servo motors. Provided for the controllers of MR-H11KACN or more.
	Grounding	Ground terminal Connect this terminal to the protective earth (PE) terminals of the servo motor and control box for grounding.

## 5. SIGNALS AND WIRING

### 5.3.3 Power-on sequence

#### (1) Power-on procedure

- 1) Always wire the power supply as shown in above Section 5.3.1 using the magnetic contactor with the main circuit power supply. Configure up an external sequence to switch off the magnetic contactor as soon as an alarm occurs.
- 2) Switch on the control circuit power supply L11, L21 simultaneously with the main circuit power supply or before switching on the main circuit power supply. If the main circuit power supply is not on, the display shows the corresponding warning. However, by switching on the main circuit power supply, the warning disappears and the controller will operate properly.
- 3) The controller can accept the servo-on signal (SON) about 1 second after the main circuit power supply is switched on. Therefore, when SON is switched on simultaneously with the three-phase power supply, the base circuit will switch on in about 1 second, and the ready signal (RD) will switch on in further about 20ms, making the controller ready to operate.

#### (2) Timing chart

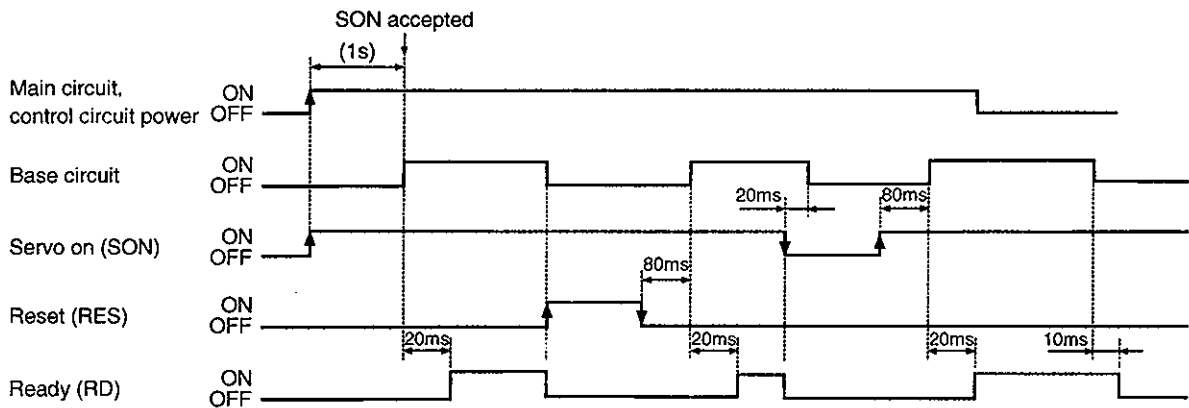

#### (3) Emergency stop



#### CAUTION

- To stop operation and switch power off immediately, provide an external emergency stop circuit.

Make up a circuit which shuts off main circuit power as soon as EMG-SG are opened at an emergency stop. To ensure safety, always install an external emergency stop switch across EMG-SG. By disconnecting EMG-SG, the dynamic brake is operated to bring the servo motor to a sudden stop. At this time, the display shows the servo emergency stop warning (ALE6).

During ordinary operation, do not use the external emergency stop signal to alternate stop and run. For the MR-H-ACN, if the start signal is on or a pulse train is input during an emergency stop, the servo motor will rotate as soon as the warning is reset. During an emergency stop, always shut off the run command.

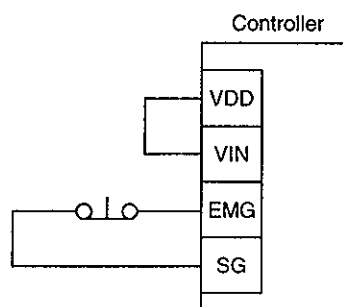

## 5. SIGNALS AND WIRING

---

### 5.4 Connection of Controller and Servo Motor

#### 5.4.1 Connection instructions



**WARNING** • Insulate the connections of the power supply terminals to prevent an electric shock.



**CAUTION**

- Connect the wires to the correct phase terminals (U, V, W) of the controller and servo motor. Otherwise, the servo motor will operate improperly.
- Do not connect AC power supply directly to the servo motor. Otherwise, a fault may occur.

- (1) Wind an insulation tape around the connection several times. For the EN Standard-compliant model, connect via a fixed terminal block.

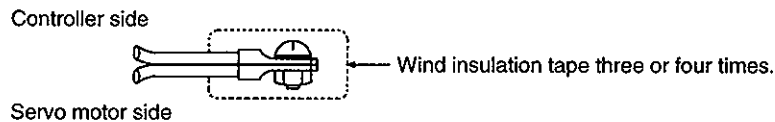

- (2) For grounding, connect the earth cable of the servo motor to the ground terminal of the controller and connect the ground cable of the controller to the earth via earth plate of the control box.

- (3) Supply exclusive 24VDC power to the brake lead of the servo motor with electromagnetic brake.

The connection method differs according to the series and capacity of the servo motor and whether or not the servo motor has the electromagnetic brake. Perform wiring in accordance with this section.

#### 5.4.2 Connection diagram

The following table lists wiring methods according to the servo motor types. Use the connection diagram which conforms to the servo motor used. For cables required for wiring, refer to Section 15.2.1. For encoder cable connection, refer to Section 15.1.6.

For the signal layouts of the connectors, refer to Section 5.2.2.

## 5. SIGNALS AND WIRING

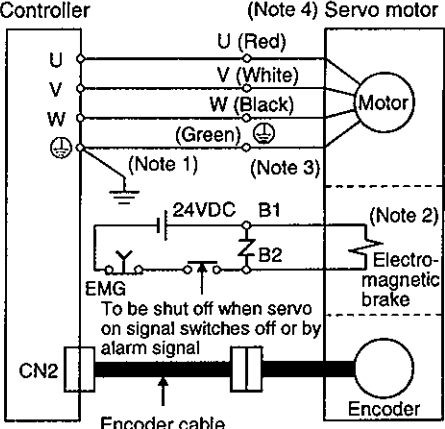
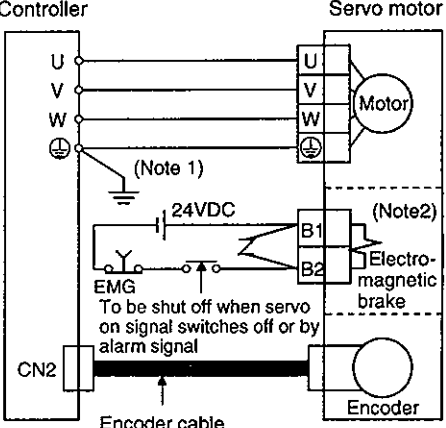
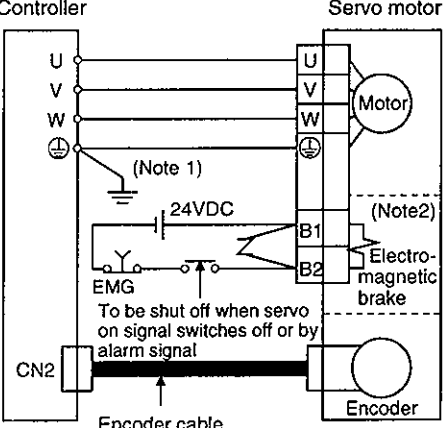
Servo Motor	Connection Diagram
<p>HA-LH11K2 to HA-LH22K            HC-MF053 (B) (-UE) to            HC-MF73 (B) (-UE)            HA-FF053 (B) to HA-FF63 (B)            HC-UF13 (B) to HC-UF73 (B)</p>	 <p><b>Note 1.</b> To prevent an electric shock, always connect the earth terminal of the controller to the earth of the control box.</p> <p><b>Note 2.</b> This circuit applies to the servo motor with electromagnetic brake.</p> <p><b>Note 3.</b> For the HA-FF series, connect the ground cable to the earth terminal of the servo motor.</p> <p><b>Note 4.</b> The HA-LH11K2 to HA-LH22K2 are equipped with a cooling fan. For wiring, refer to Section 5.4.4.</p>
<p>HA-FF053 (B)-UE to HA-FF63C (B)-UE            HC-SF121 (B) to HC-SF301 (B)            HC-SF202 (B) to HC-SF702 (B)            HC-SF203 (B) · HC-SF353 (B)            HC-UF202 (B) to HC-CF502(B)</p>	 <p><b>Note 1.</b> To prevent an electric shock, always connect the earth terminal of the controller to the earth of the control box.</p> <p><b>Note 2.</b> This circuit applies to the servo motor with electromagnetic brake.</p>
<p>HC-SF52 (B) to HC-SF152 (B)            HC-RF103 (B) to HC-RF503 (B)            HC-UF72 (B) · HC-UF152 (B)</p>	 <p><b>Note 1.</b> To prevent an electric shock, always connect the earth terminal of the controller to the earth of the control box.</p> <p><b>Note 2.</b> This circuit applies to the servo motor with electromagnetic brake.</p>

## 5. SIGNALS AND WIRING

### 5.4.3 Details of the servo motor side

#### (1) HC-MF(-UE) series

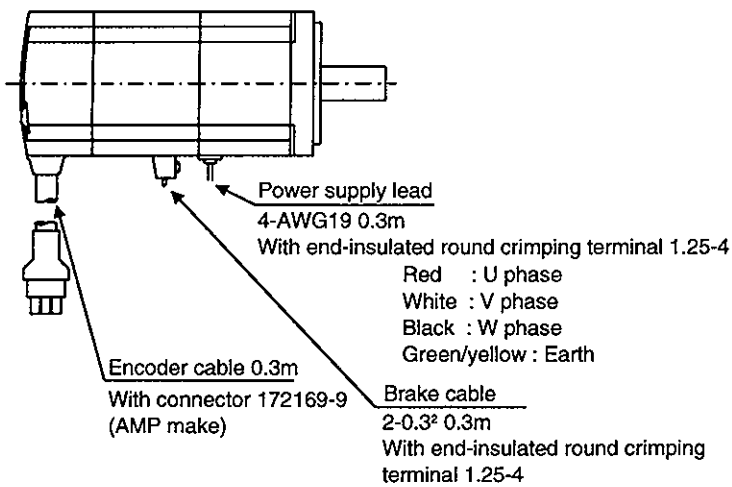

Encoder connector signal arrangement

1	2	3
MR	MRR	BAT
4	5	6
MD	MDR	CNT
7	8	9
P5	LG	SHD

#### (2) HA-FF series

Earth terminal, M3 screw

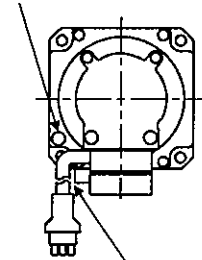

Encoder cable 0.3m  
With connector 172169-9  
(AMP make)

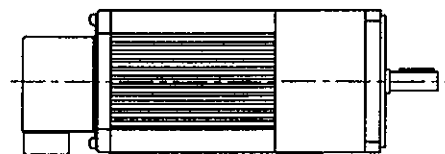

Power supply cable  
VCTF3-1.25<sup>2</sup> 0.5m  
With end-insulated round crimping terminal 1.25-4  
Red : U phase  
White : V phase  
Black : W phase

Brake cable  
VCTF2-0.5<sup>2</sup> 0.5m  
With end-insulated round crimping terminal 1.25-4

Encoder connector signal arrangement

1	2	3
MR	MRR	BAT
4	5	6
MD	MDR	CNT
7	8	9
P5	LG	SHD



## 5. SIGNALS AND WIRING

### (3) HA-FF□C(B)-UE series

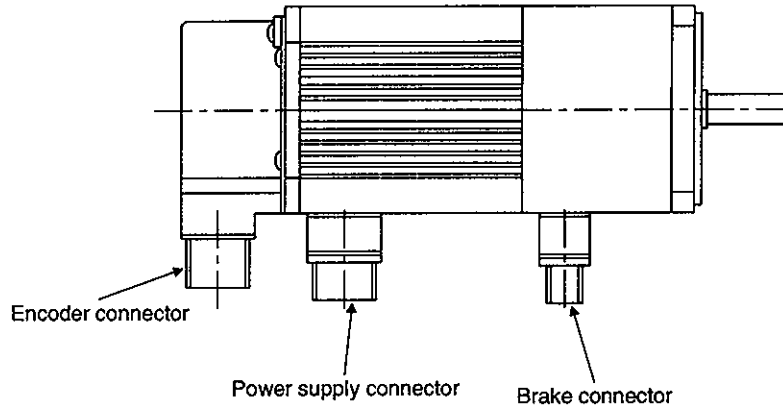

Servo Motor	Connector		
	For Power Supply	For Encoder	For Brake
HA-FF053C(B)-UE to HA-FF63C(B)-UE	CE05-2A14S-2PD-B	MS3102A20-29	MS3102E10SL-4P

Power supply connector  
signal arrangement  
CE05-2A14S-2PD-B

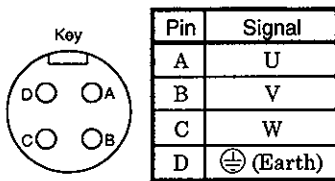

Encoder connector signal  
arrangement  
MS3102A20-29P

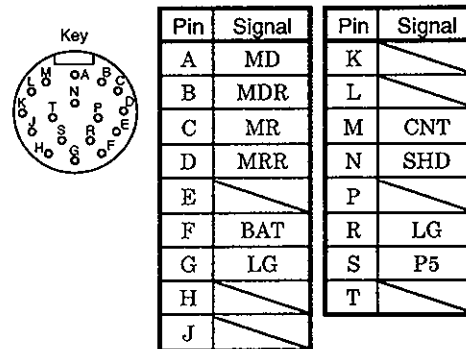

Brake connector signal  
arrangement  
MS3102E10SL-4P

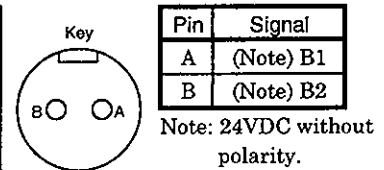

### (4) HC-UF(B) 3000r/min series

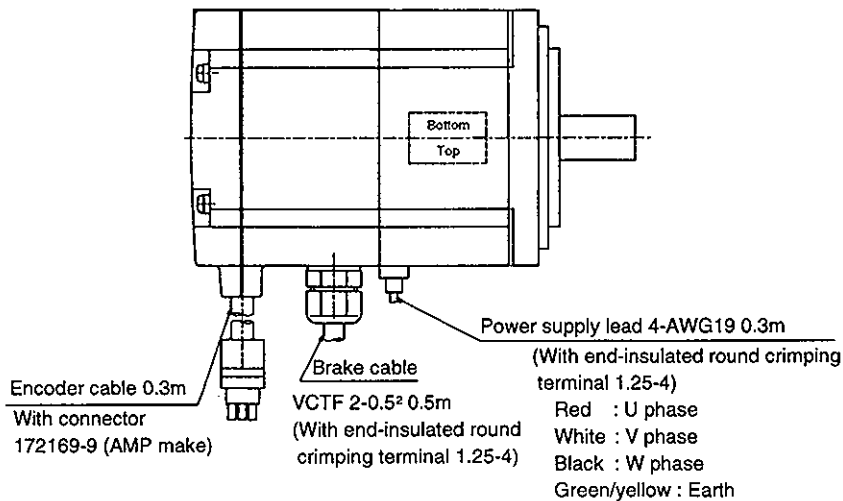

Encoder connector  
signal arrangement

1	2	3
MR	MRR	BAT
4	5	6
MD	MDR	CNT
7	8	9
P5	LG	SHD

## 5. SIGNALS AND WIRING

(5) HC-SF□(B) · HC-RF□(B) · HC-U□(B)F2000 r/min series

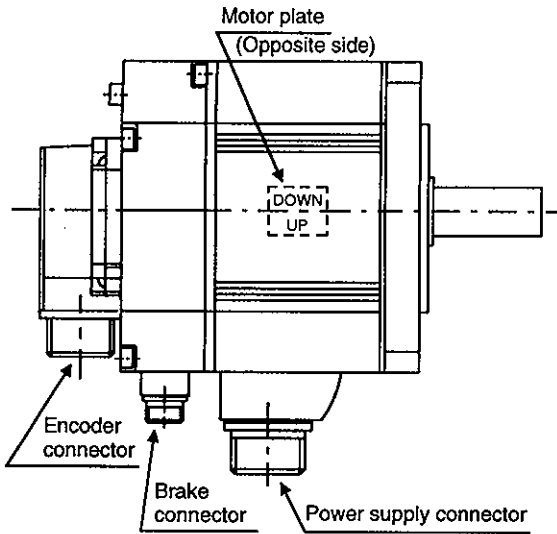

Servo Motor	Servo Motor Side Connectors		
	For Power Supply	For Encoder	Electromagnetic Brake Connector
HC-SF81(B) HC-SF52(B) to 152(B) HC-SF53(B) to 153(B)	CE05-2A22-23PD-B	MS3102A20-29P	Also used by power supply
HC-SF121(B) to 301(B) HC-SF202(B) to 502(B) HC-SF203(B)-353(B)	CE05-2A24-10PD-B		MS3102A10SL-4P
HC-SF702(B)	CE05-2A32-17PD-B		Also used by power supply
HC-RF103(B) to 203(B)	CE05-2A22-23PD-B		MS3102A10SL-4P
HC-RF353(B)-503(B)	CE05-2A24-10PD-B		
HC-UF72(B)-152(B)	CE05-2A22-23PD-B		
HC-UF202(B) to 502(B)	CE05-2A24-10PD-B		

Power supply connector signal arrangement

CE05-2A22-23PD-B

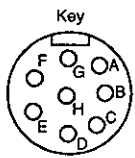

Pin	Signal
A	U
B	V
C	W
D	⊕ (Earth)
E	
F	
G	(Note) B1
H	(Note) B2

Note: 24VDC, without polarity

CE05-2A24-10PD-B

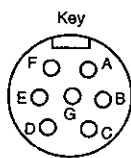

Pin	Signal
A	U
B	V
C	W
D	⊕ (Earth)
E	(Note) B1
F	(Note) B2
G	

Note: 24VDC, without polarity

CE05-2A32-17PD-B

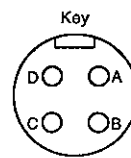

Pin	Signal
A	U
B	V
C	W
D	⊕ (Earth)

Encoder connector signal arrangement

MS3102A20-29P

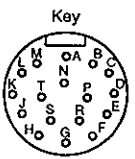

Pin	Signal	Pin	Signal
A	MD	K	
B	MDR	L	
C	MR	M	CNT
D	MRR	N	SHD
E		P	
F	BAD	R	LG
G	LG	S	P5
H		T	
J			

Electromagnetic brake connector signal pin-outs

MS3102E10SL-4P

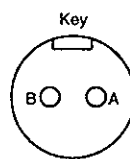

Pin	Signal
A	(Note) B1
B	(Note) B2

Note: 24VDC without polarity

## 5. SIGNALS AND WIRING

### (6) HA-LH11K2(-EC) to HA-LH22K2(-EC)

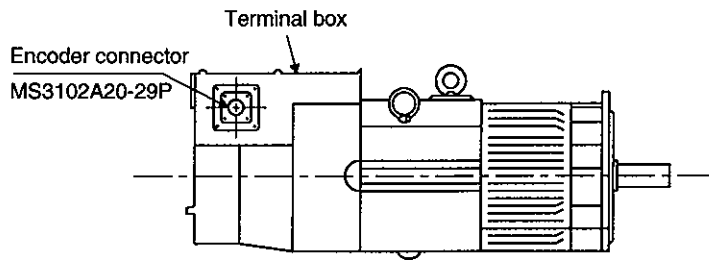

Encoder connector  
signal arrangement  
MS3102A-29P

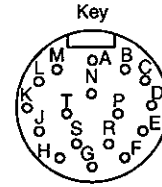

Pin	Signal	Pin	Signal
A	MD	K	
B	MDR	L	
C	MR	M	CNT
D	MRR	N	SHD
E		P	
F	BAT	R	LG
G	LG	S	P5
H		T	
J			

#### (a) Terminal box of HA-LH11K2 to HA-LH22K2

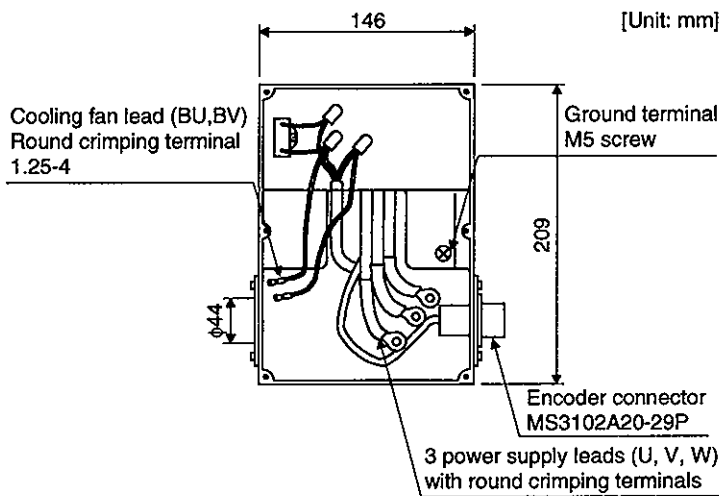

Power supply connection screw size

Servo Motor	Power Supply Connection Screw Size
HA-LH11K2	8-6
HA-LH15K2 · 22K2	14-6

#### (b) Terminal box of HA-LH11K2-EC to HA-LH22K2-EC Protective earth (PE)

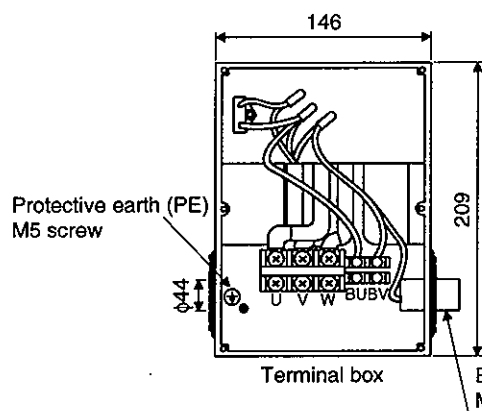

Signal arrangement of terminal block

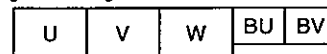

Servo Motor	Power Supply Connection Screw Size	Fan Connection Screw Size
HA-LH11K2-EC	M6	M4
HA-LH15K2-EC · LH22K2-EC	M8	M4

## 5. SIGNALS AND WIRING

### 5.4.4 Servo motor fan (HA-LH11K2 to HA-LH22K2)

The 11kW or more of the HA-LH series are of totally-enclosed, force-cooled type. When performing operation, supply power to the cooling fan terminals (BU, BV) to operate the cooling fan. (Single-phase 200V, 35W)

Connect the fan terminals (BU, BV) of the servo motor to the cooling fan power terminals MS1, MS2 of the controller.

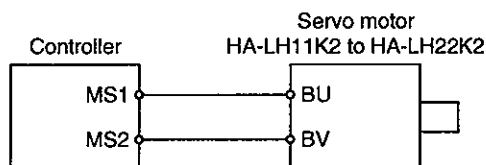

### 5.5 Servo Motor with Electromagnetic Brake

- The electromagnetic brake is designed to hold the motor shaft and should not be used for ordinary braking. For such reasons as service life and mechanical structure (e.g. where a ballscrew and the servo motor are coupled via a timing belt), the electromagnetic brake may not hold the motor shaft. To ensure safety, install a stopper on the machine side.
- Configure the electromagnetic brake operation circuit so that it is activated not only by the controller signals but also by an external emergency stop signal.

 CAUTION

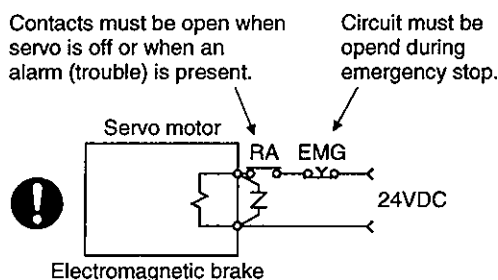

Use a servo motor with electromagnetic brake which is designed to prevent a load drop on a vertical shaft or which ensures double safety at an emergency stop. When using the servo motor with electromagnetic brake, set □□□1 in parameter No. 3 to make the electromagnetic brake interlock signal available. When this signal is used, the zero speed detection signal is made unavailable. Refer to the connection diagram in Section 5.3.1 and make connection.

#### 5.5.1 Wiring instructions

- 1) Do not share the 24VDC interface power supply between the interface and electromagnetic brake. Always use the power supply designed exclusively for the electromagnetic brake.
- 2) The brake will operate when the power (24VDC) switches off.
- 3) The electromagnetic brake has no polarity. When connecting the power supply, wire it independently of polarity.

## 5. SIGNALS AND WIRING

### 5.5.2 Operation of electromagnetic brake

(1) Electromagnetic brake operates when alarm occurs, emergency stop is valid, or SON signal is off

(a) Setting

Set □0□□ (initial value) in parameter No. 44.

(b) Timing chart

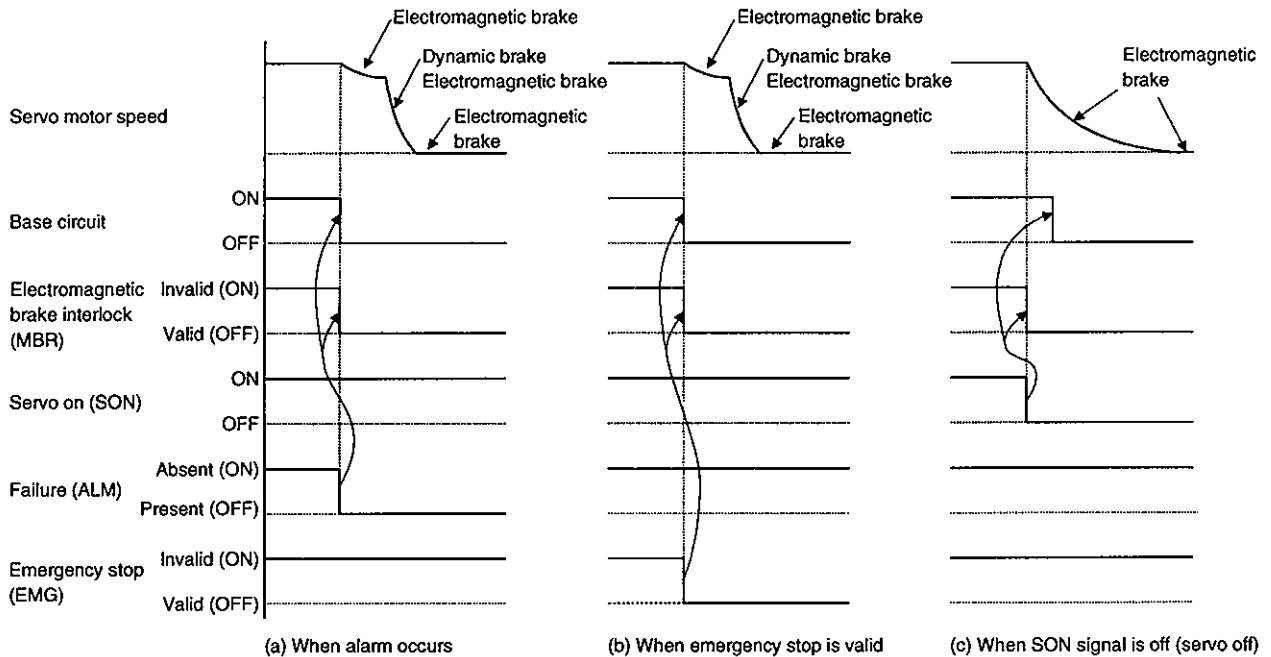

(2) Electromagnetic brake operates under the condition in (2) (b) of this section and at zero speed

(a) Setting

- 1) Set □1□□ in parameter No. 44.
- 2) Using parameter No.3 (feed system), set the function of CN! Pin 23 (COP) to make the electromagnetic brake interlock output signal (BRK) valid.
- 3) In parameter No. 53, set a time delay (T<sub>b</sub>) between electromagnetic brake operation and base circuit shut-off.
- 4) In this usage, do not install the EMG switch in Note 2 in the connection diagram of Section 5.3.1.

## 5. SIGNALS AND WIRING

### (b) Timing chart

#### 1) Servo ON, reset timing chart.

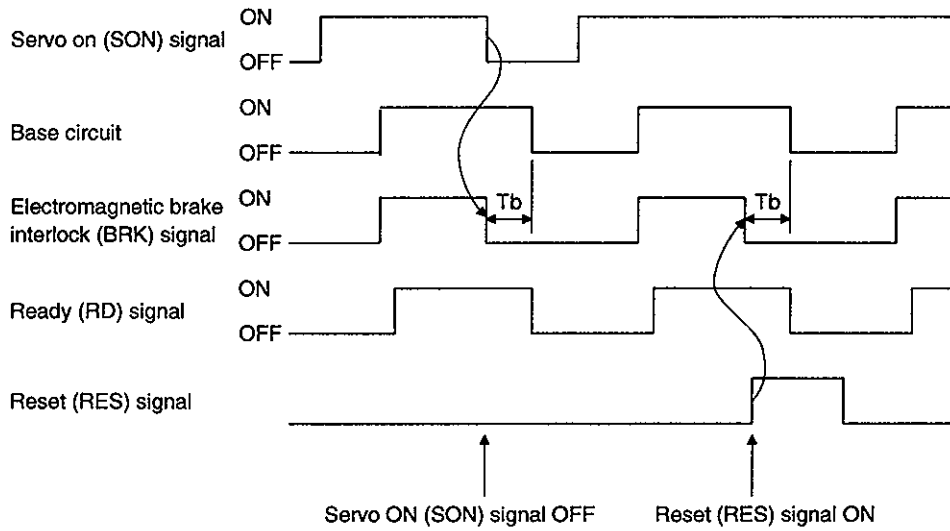

#### 2) Alarm occurrence or emergency stop validity timing chart.

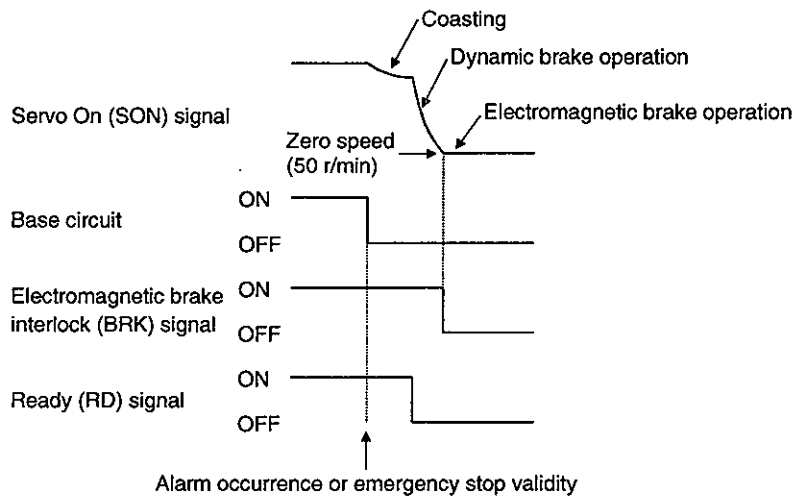

## 5. SIGNALS AND WIRING

### 5.6 Grounding



**WARNING** • Ground the controller and servo motor securely.

The controller switches the power transistor on-off to supply power to the servo motor. Depending on the wiring and ground cablerouting, the controller may be affected by the switching noise (due to di/dt and dv/dt) of the transistor. To prevent such a fault, refer to the following diagram and use a flat mesh copper cable, which is as large as possible (3.5mm<sup>2</sup> or larger is desirable), for grounding.

To conform to the EMC Directive, refer to the EMC INSTALLATION GUIDELINES (IB(NA)67310).

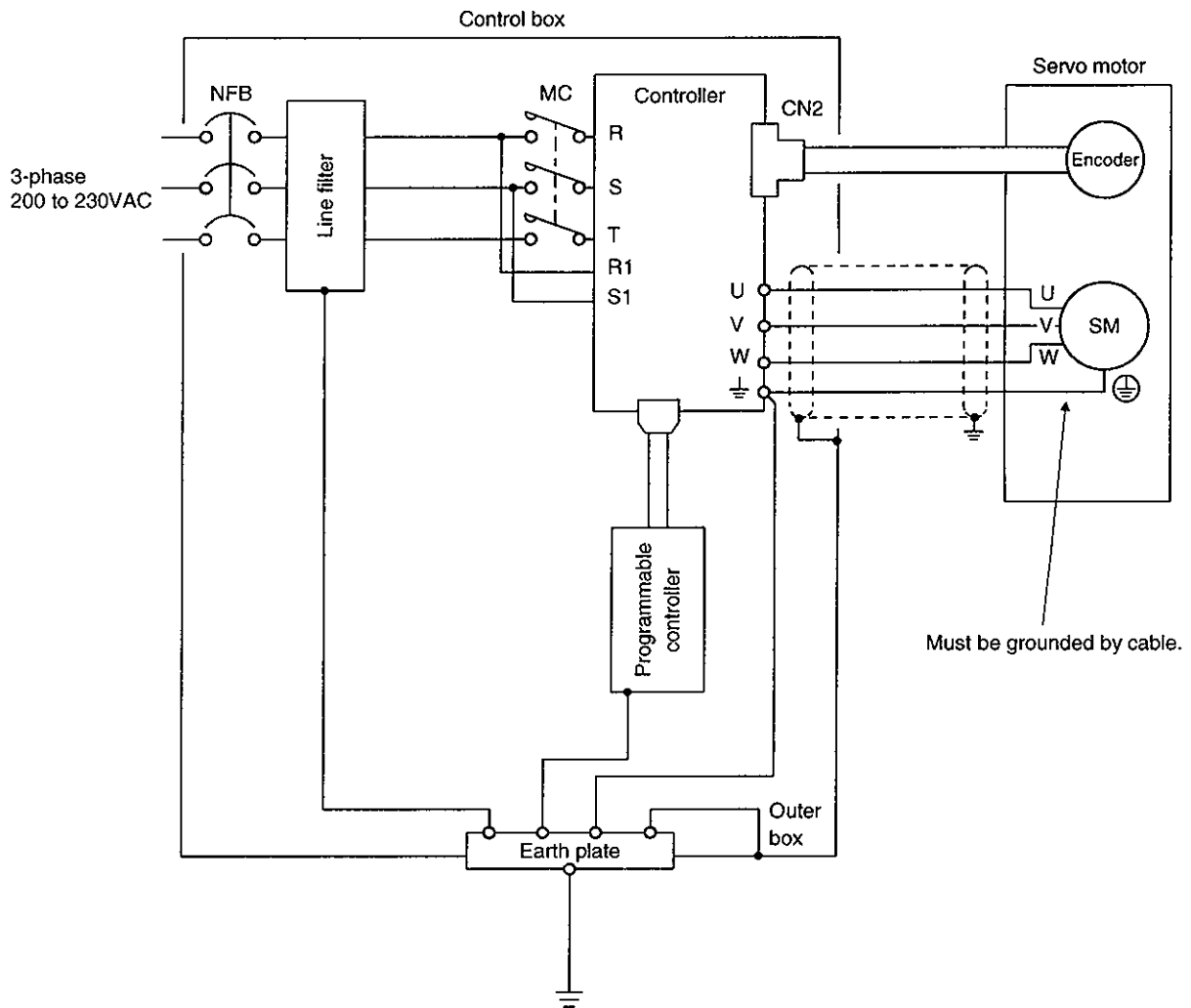

## 5. SIGNALS AND WIRING

### 5.7 Alarm Occurrence Timing Chart



#### CAUTION

- When an alarm has occurred, remove its cause, make sure that the operation signal is not being input, ensure safety, and reset the alarm before restarting operation.

When an alarm occurs in the controller, the base circuit is shut off and the servo motor is coated to a stop. Switch off the main circuit power supply in the external sequence. To reset the alarm, switch the control circuit power supply off, then on or turn the reset signal (RES) off, then on. However, the alarm cannot be reset unless its cause is removed.

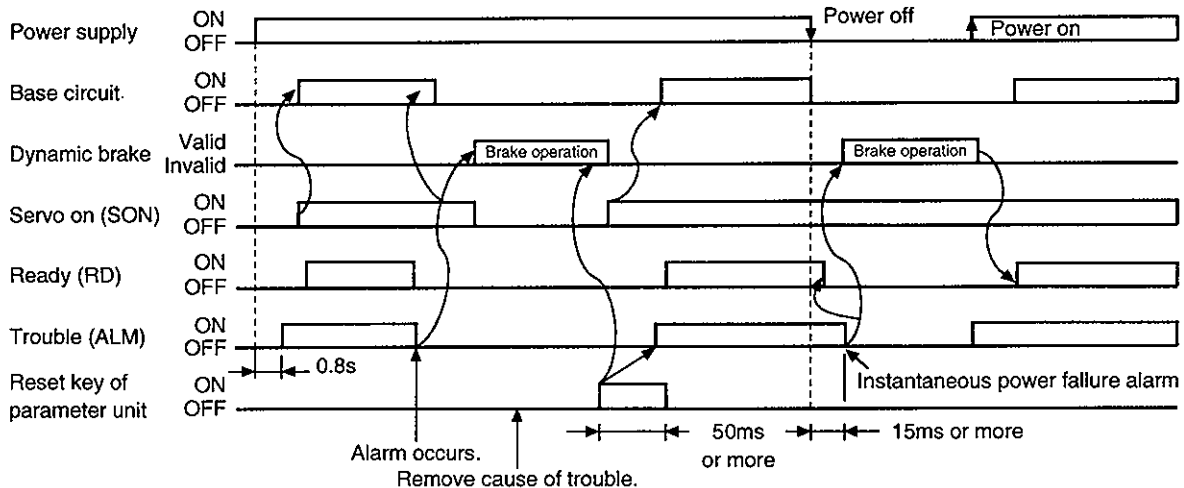

#### Precautions for alarm occurrence

##### 1) Overcurrent, overload 1 or overload 2

If operation is repeated by switching control circuit power off, then on to reset the overcurrent (AL32), overload 1 (AL50) or overload 2 (AL51) alarm after its occurrence, without removing its cause, the controller and servo motor may become faulty due to temperature rise. Securely remove the cause of the alarm and also allow about 30 minutes for cooling before resuming operation.

##### 2) Regenerative alarm

If operation is repeated by switching control circuit power off, then on to reset the regenerative (AL30) alarm after its occurrence, the external regenerative brake resistor will generate heat, resulting in an accident.

##### 3) Instantaneous power failure

If a power failure continues 15ms or longer, the undervoltage (AL10) alarm will occur. If the power failure still persists for 20ms or longer, the control circuit is switched off. When the power failure is reset in this state, the alarm is reset and the servo motor will start suddenly if the servo-on signal (SON) is on. To prevent hazard, make up a sequence which will switch off the servo-on signal (SON) if an alarm occurs.

##### 4) Incremental system

When an alarm occurs, the home position is lost. When resuming operation after deactivating the alarm, make a return to home position.



## 6. PARAMETERS

### 6. PARAMETERS



#### CAUTION

- Never adjust or change the parameter values extremely as it will make operation instable.

#### 6.1 Parameter List

##### 6.1.1 Parameter write inhibit

In the MR-H-ACN single-axis amplifier built-in controller, its parameters are classified into the basic parameters (No.0 to 20) and expansion parameters (No.21 to 64) and option parameters according to their safety aspects and frequencies of use. In the factory setting condition, the customer can change the basic parameter values but cannot change the expansion parameter values. When fine adjustment, e.g. gain adjustment, is required, change the parameter No.20 setting to make the expansion parameters write-enabled.

Parameter No.20 is made valid by setting its value and then switching power off, then on.

Parameter No.20 Setting	Operation	Parameters No.0 to No.20	Parameters No.21 to No.79
□□□0 (initial value)	Reference	○	
	Write	○	
□□□A	Reference	No.20 only	
	Write	No.20 only	
□□□C	Reference	○	○
	Write	○	○
□□□E	Reference	○	○
	Write	○	○

When using the MR-H-D01 option card, the write-enabled range changes as follows:

Parameter No.20 Setting	Operation	Parameters No.0 to No.20	Parameters No.21 to No.64	Parameters No.65 to No.79
□□□0 (initial value)	Reference	○		○
	Write	○		○
□□□A	Reference	No.20 only		
	Write	No.20 only		
□□□C	Reference	○	○	○
	Write	○		
□□□E	Reference	○	○	○
	Write	○	○	○

## 6. PARAMETERS

### 6.1.2 Lists

POINT
<ul style="list-style-type: none"> <li>• For any parameter whose symbol is preceded by *, set the parameter value and switch power off once, then switch on again to make that parameter setting valid.</li> <li>• When using the HC-MF, HA-FF, HC-SF, HC-RF or HC-UF series servo motor, the values of parameters No. 0 and 1 need not be set. They are automatically judged by simply connecting the servo motor. At this time, the settings of these parameters are ignored.</li> </ul>

For details of the parameters, refer to the corresponding items.

The symbols in the Feeding System column of the table denote the following:

P: Positioning system

R: Roll feeding system

#### (1) Item list

classification	No.	Code	Name	Parameter Unit Screen Display	Feeding system	Initial value	Unit	Customer Setting
Basic parameters	0	*MSR	Motor series	0 MTR ser.		—		
	1	*MTY	Motor type	1 MTR type		—		
	2	*FTY	Feeding system, regenerative brake option selection	2 Feed mode		0001		
	3	*ST1	Function selection 1	3 Function 1	P, R	0000		
	4	*ST2	Function selection 2	4 Function 2		0000		
	5	*CMX	Electronic gear numerator	5 E-gear-N		1		
	6	*CDV	Electronic gear denominator	6 E-gear-D		1		
	7	PG1	Position control gain 1	7 Pos. gain 1		70	rad/s	
	8	JG1	Jog speed 1	8 JOGspeed1		100	r/min	
	9	JG2	Jog speed 2	9 JOGspeed2	R	1000	r/min	
		*ZTY	Zeroing type	9 ORG type	P	0010		
			Space	10 blank	R			
	10	ZSP	Zeroing position data	10 ORG Add	P	0	Command unit $\times 10^{\text{STM}} \times 10^{-3}$	
			Space	11 blank	R			
	11	ZRF	Zeroing speed	11 ORG Speed	P	500	r/min	
			Space	12 blank	R			
	12	CRF	Creep speed	12 ORG Creep	P	10	r/min	
			Space	13 blank	R			
	13	ZST	Zero shift distance	13 ORG shift	P	0	Command unit	
		Space	14 blank	R				
14	DCT	Moving distance after proximity dog signal ON	14 Near Dog	P	1000	Command unit $\times 10^{\text{STM}} \times 10^{-3}$		
		Space	15 blank	R				
15		Second home position data	15 ORG Add. 2	P	100	Command unit $\times 10^{\text{STM}} \times 10^{-3}$		
16	INP	In-position range	16 IPN zone		25			
17	CRP	Rough match output range	17 CRP zone		0			
18	MOD	Analog monitor output	18 Moni. sel.	P, R	0001			
19	DMD	Status display selection	19 Disp. sel.		0000		Command unit $\times 10^{\text{STM}} \times 10^{-3}$	

## 6. PARAMETERS

Classification	No.	Code	Name	Parameter Unit Screen Display	Feeding system	Initial value	Unit	Customer Setting
Expansion parameters	20	*BLK	Parameter/point table write inhibit	20 Pr. block		0000		
	21	AUT	Auto tuning	21 AT tuning		0001		
	22	*OP1	Function selection 3	22 Function3		0000		
	23	*OP2	Function selection 4	23 Function4		0000		
	24	*OP3	Function selection 5	24 Function5	P, R	0000		
	25	BKC	Backlash compensation	25 Backlash		0	pulse	
	26	FFC	Feed forward gain	26 FF gain		0	%	
	27	ERZ	Excessive error alarm level	27 AL52level		80	K pulse	
	28	INT	In-position output time	28 INP time		0	ms	
	29	*RMX	For manufacturer setting	29 PulsFunc1		0120		
	30	RM2	Pulse input function 2	30 PulsFunc2		0000		
	31	*DSP	Current position display function selection	31 Pos Disply	R	0000		
			Spare	31 blank	P			
	32		Spare	32 blank				
	33		Spare	33 blank				
	34		Spare	34 blank				
	35		Spare	35 blank				
	36		Spare	36 blank				
	37		Spare	37 blank				
	38		Spare	38 blank				
	39	*ENR	Encoder output pulse	39 PLG pulse		2048	pulse	
	40	TL	Internal torque limit 1	40 TQ limit1		100		
	41	*IP1	Input signal selection 1	41 DI sel. 1		P:0100 R:0000		
	42	*IP2	Input signal selection 2	42 DI sel. 2		0000		
	43		Spare	43 blank				
	44	*OPC	Output signal selection	44 DO sel.		0000		
	45		Spare	45 blank				
	46	*MOA	Pre-alarm data selection	46 ALM memo		0001		
	47	VOC	VC offset	47 VC offset		0	mV	
	48	TPO	TLAP offset	48 TLAP ofset		0	mV	
	49		Spare	49 blank				
	50	M01	MO1 offset	50 MO1offset	P, R	0	mV	
	51	M02	MO2 offset	51 MO2offset		0	mV	
	52	*SIO	External digital display selection	52 SIO sel.		0101		
	53	MBR	Electromagnetic brake sequence output	53 BRKtiming		100	ms	
	54	TL2	Internal torque limit value 2	54 TQ limit2		100	%	
	55		Spare	55 blank		0		
	56		Spare	56 blank		0		
	57		Spare	57 PID droop		0		
	58	DG2	Ratio of load inertia moment to servo motor inertia moment	58 Inertia		2.0		
	59	NCH	Machine resonance control filter	59 M-filter		0		
	60	PG2	Position control gain 2	60 Pos.gain2		25	rad/s	
	61	VG1	Speed control gain 1	61 V-gain 1		1200	rad/s	
	62	VG2	Speed control gain 2	62 V-gain 2		600	rad/s	
	63	VIC	Speed integral compensation	63 V-int com		20	ms	
	64	VDC	Speed differential compensation	64 V-dif com		980		

## 6. PARAMETERS

Parameter List for Use When the MR-H-D01 Option Card Is Loaded

classification	No.	Code	Name	Parameter Unit Screen Display	Feeding system	Initial value	Unit	Customer Setting
Optional parameters	65	*DI1	D-1 extension function selection 1	65 OP. DI1	P, R	1000		
	66	*DI2	Extension function selection 2	66 OP. DI2		0000		
	67	*DOS	Extension function selection	67 OP.DO		0000		
	68	*APS	For manufacturer setting	68 OP.pulse		0120		
	69		Spare	69 blank				
	70		Spare	70 blank				
	71		Spare	71 blank				
	72		Spare	72 blank				
	73		Spare	73 blank				
	74		Spare	74 blank				
	75		Spare	75 blank				
	76		Spare	76 blank				
77		Spare	77 blank					
78		Spare	78 blank					
79		Spare	79 blank					

## 6. PARAMETERS

### (2) Detail List

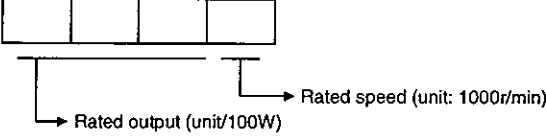
Classification	No.	Code	Name and Function	Feeding system	Initial value	Unit	Setting Range												
Basic parameters	0	*MSR	<p>Motor series</p> <p>Used to select the series of the servo motor.</p> <p>When using the HC-MF, HA-FF, HC-SF, HC-RF or HC-UF series servo motor, the value of this parameter need not be set since it is automatically judged by simply connecting the servo motor encoder and controller. At this time, the value of this parameter remains unchanged but use it as it is.</p> <table border="1" style="margin-left: auto; margin-right: auto;"> <thead> <tr> <th>Set Value</th> <th>Servo Motor Series</th> </tr> </thead> <tbody> <tr> <td>0000</td> <td>HA-SH</td> </tr> <tr> <td>0001</td> <td>HA-LH</td> </tr> <tr> <td>0002</td> <td>HA-UH</td> </tr> <tr> <td>0003</td> <td>HA-FH</td> </tr> <tr> <td>0005</td> <td>HA-MH</td> </tr> </tbody> </table>	Set Value	Servo Motor Series	0000	HA-SH	0001	HA-LH	0002	HA-UH	0003	HA-FH	0005	HA-MH				0000 to 0005
	Set Value	Servo Motor Series																	
0000	HA-SH																		
0001	HA-LH																		
0002	HA-UH																		
0003	HA-FH																		
0005	HA-MH																		
	1	*MTY	<p>Motor type</p> <p>Set the parameter (servo motor capacity) according to the servo motor used.</p> <p>When using the HC-MF, HA-FF, HC-SF, HC-RF or HC-UF series servo motor, the value of this parameter need not be set since it is automatically judged by simply connecting the servo motor encoder and controller. At this time, the value of this parameter remains unchanged but use it as it is.</p> <div style="text-align: center;">  <p>Indicated on the next page</p> </div>																

## 6. PARAMETERS

Classification	No.	Code	Name and Function	Feeding system	Initial value	Unit	Setting Range														
Basic parameters	1	*MTY	Controller MR-H□ACN											As given in the Left table	As given in the Left table						
				Servo motor	Capacity (W)	10	20	40	60	100	200	350	500			700	11K	15K	22K		
			Ultracompact	HA-MH053	50		053														
				HA-MH13	100		13														
				HA-MH23	200			23													
				HA-MH43	400				43												
				HA-MH73	750					73											
			Small capacity	HA-FH053	50		053														
				HA-FH13	100		13														
				HA-FH23	200			23													
				HA-FH33	300				33												
				HA-FH43	400					43											
				HA-FH63	600						63										
			1000r/min	HA-SH81	850						81										
				HA-SH121	1200							121									
				HA-SH201	2000								201								
				HA-SH301	3000											301					
			2000r/min	HA-SH52	500																
				HA-SH102	1000																
				HA-SH152	1500																
				HA-SH202	2000																
				HA-SH352	3500																
				HA-SH502	5000																
			3000r/min	HA-SH702	7000																
				HA-SH53	500																
				HA-SH103	1000																
				HA-SH153	1500																
			Low inertia	HA-LH203	2000																
				HA-SH353	3500																
HA-LH52	500																				
HA-LH102	1000																				
HA-LH152	1500																				
HA-LH202	2000																				
Large capacity	HA-LH302	3000																			
	HA-LH502	5000																			
	HA-LH702	7000																			
Pancake	HA-LH11K2	11000																			
	HA-LH15K2	15000																			
	HA-LH22K2	22000																			
	HA-UH32	300																			
	HA-UH52	500																			
	HA-UH102	1000																			
HA-UH152	1500																				
HA-UH222	2200																				
HA-UH352	3500																				
HA-UH452	4500																				

The values enclosed by  are factory-set values.

 **CAUTION**

- The parameter values given in the following table indicate that the corresponding controllers and servo motors may be used together. If the other value is set, a fire may take place.

## 6. PARAMETERS

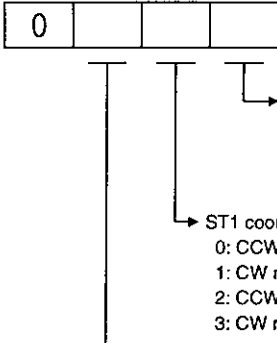
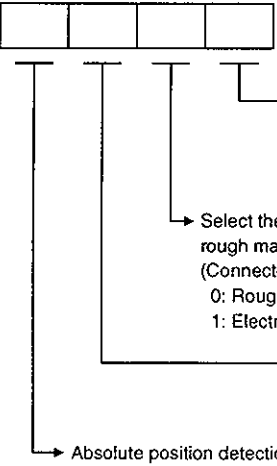
Classification	No.	Code	Name and Function	Feeding system	Initial value	Unit	Setting Range
Basic parameters	2	*FTY	<p>Feeding system, regenerative brake option selection Used to select the feeding system and regenerative brake option.</p>  <p> <b>Feed command system</b>            0: Roll feeding (R)            1: Positioning incremental command system            2: Positioning absolute command system } (P)         </p> <p> <b>ST1 coordinate system selection....Title</b>            0: CCW rotation (address increase)            1: CW rotation (address increase)            2: CCW rotation (address decrease)            3: CW rotation (address decrease)         </p> <p> <b>Select the regenerative brake option.</b>            0: Set 0 when the servo amplifier of 7kW or less capacity has no external option or when the servo amplifier of 11kW or more uses the supplied regenerative brake resistor or regenerative brake option without a fan.            1: FR-RC, FR-BU brake unit            2: MR-RB013            3: MR-RB033            5: MR-RB32            6: MR-RB34            7: MR-RB54            8: MR-RB30            9: MR-RB50            B: MR-RB31            C: MR-RB51            E: When the servo amplifier is 11kW or more and the supplied regenerative brake resistor or regenerative brake option is cooled by a fan to increase its capability.         </p> <p>(If the regenerative brake option selected cannot be used with the MR-H-ACN, the corresponding parameter error occurs.)</p>	P, R	0001		0000 to 0E33
	3	*ST1	<p>Function selection 1 Used to choose the optional functions.</p>  <p> <b>Acceleration/deceleration pattern</b>            0: Linear acceleration/deceleration            1: S-shaped acceleration/deceleration         </p> <p> <b>Select the electromagnetic brake interlock signal or rough match signal.</b>            (Connector CPO (pin 23) is changed in function)            0: Rough match signal valid            1: Electromagnetic brake interlock signal valid         </p> <p> <b>Select the external dynamic brake.</b>            0: Without the external dynamic brake            1: With the external dynamic brake         </p> <p> <b>Absolute position detection system selection</b>            0: Invalid (when using the controller in incremental system)            1: Valid (when using the controller in absolute position detection system)         </p>	P, R	0000		0000 to 1111h

## 6. PARAMETERS

classification	No.	Code	Name and Function	Feeding system	Initial value	Unit	Setting Range																																																		
Basic parameters	4	*ST2	<p>Function selection 2 Used to choose the optional functions.</p> <div style="display: flex; align-items: center;"> <div style="border: 1px solid black; padding: 2px; margin-right: 10px;">0</div> <div style="margin-right: 10px;"> </div> <div style="border: 1px solid black; width: 20px; height: 20px; display: flex; align-items: center; justify-content: center;"> </div> <div style="margin-right: 10px;"> </div> <div style="border: 1px solid black; width: 20px; height: 20px; display: flex; align-items: center; justify-content: center;"> </div> <div style="margin-right: 10px;"> </div> <div style="border: 1px solid black; width: 20px; height: 20px; display: flex; align-items: center; justify-content: center;"> </div> </div> <p style="margin-left: 40px;">             The magnification (STM) can be set to position data set in the position block number or by the digital switch. Refer to the following table.         </p> <table border="1" style="margin-left: 40px;"> <thead> <tr> <th>Set Value (STM)</th> <th>Magnification</th> </tr> </thead> <tbody> <tr> <td>0</td> <td>1 time</td> </tr> <tr> <td>1</td> <td>10 times</td> </tr> <tr> <td>2</td> <td>100 times</td> </tr> <tr> <td>3</td> <td>1000 times</td> </tr> </tbody> </table> <p style="margin-left: 40px;">             Unit of position data              0: Metric system              1: Inch system              (The unit on the machine speed screen is:              mm: mm/m              inch: inch/m)         </p> <p>             Decimal point position setting              The decimal point position can be moved as desired on the monitor screen.              Note that the actual moving distance depends on STM. Refer to the following table.         </p> <p>             0: Automatic setting              1: 1st digit              2: 2nd digit              3: 3rd digit              4: 4th digit         </p> <p style="text-align: center;">             Relationship between STM, decimal point position setting and monitor display         </p> <table border="1" style="margin-left: 40px;"> <thead> <tr> <th rowspan="2">STM Set Value</th> <th rowspan="2">Actual Moving Distance (μm)</th> <th colspan="5">3rd Digit Set Value (Decimal point position setting)</th> </tr> <tr> <th>0</th> <th>1</th> <th>2</th> <th>3</th> <th>4</th> </tr> </thead> <tbody> <tr> <td>0</td> <td>Position data × 1</td> <td>999.999</td> <td></td> <td></td> <td></td> <td></td> </tr> <tr> <td>1</td> <td>Position data × 10</td> <td>9999.99</td> <td>999999</td> <td>99999.9</td> <td>9999.99</td> <td>999.999</td> </tr> <tr> <td>2</td> <td>Position data × 100</td> <td>99999.9</td> <td></td> <td></td> <td></td> <td></td> </tr> <tr> <td>3</td> <td>Position data × 1000</td> <td>999999</td> <td></td> <td></td> <td></td> <td></td> </tr> </tbody> </table>	Set Value (STM)	Magnification	0	1 time	1	10 times	2	100 times	3	1000 times	STM Set Value	Actual Moving Distance (μm)	3rd Digit Set Value (Decimal point position setting)					0	1	2	3	4	0	Position data × 1	999.999					1	Position data × 10	9999.99	999999	99999.9	9999.99	999.999	2	Position data × 100	99999.9					3	Position data × 1000	999999					P, R	0000		0000 to 0413h
	Set Value (STM)	Magnification																																																							
	0	1 time																																																							
1	10 times																																																								
2	100 times																																																								
3	1000 times																																																								
STM Set Value	Actual Moving Distance (μm)	3rd Digit Set Value (Decimal point position setting)																																																							
		0	1	2	3	4																																																			
0	Position data × 1	999.999																																																							
1	Position data × 10	9999.99	999999	99999.9	9999.99	999.999																																																			
2	Position data × 100	99999.9																																																							
3	Position data × 1000	999999																																																							
	5	*CMX	<p>Electronic gear numerator</p> <p>set in the range <math>\frac{1}{50} &lt; \frac{CMX}{CDV} &lt; 50</math>.</p>	P, R	1	Pulse	1 to 50000																																																		
	6	*CDV	<p>Electronic gear denominator</p> <p>Setting example</p> <p>Roll diameter : 50mm              Reduction ratio : <math>1/n = 3/7</math>              Number of pulses : 16384 pulse/rev (for HA-SH motor)</p> $\frac{\text{Number of pulses (CMX)}}{\text{Moving distance (CDV)}} = \frac{16384}{50 \times \pi \times 3/7 \times 1000} = \frac{7168}{9375\pi} \approx \frac{7168}{29452}$ <p>Hence, set CMX to 7168 and CDV to 29452.</p> <p>When a fraction is produced, carry within the setting range and round that fraction off.</p>	P, R	1	Command unit	1 to 50000																																																		



## 6. PARAMETERS

classification	No.	Code	Name and Function	Feeding system	Initial value	Unit	Setting Range
Basic parameters	7	PG1	Position control gain 1 Used to set the gain of the position loop. Increase the gain to raise tracking performance in response to the position command.	P, R	70	rad/s	10 to 1000
	8	JG1	JOG speed 1 Used to set speed 1 of the jog speed command. The acceleration and deceleration time constants used are those of speed block No. 1	P, R	100	r/min	0 to max. speed
	9	*ZTY	Zeroing type Select the home position setting method, zeroing direction and proximity dog signal input polarity.  <div style="display: flex; align-items: center;"> <div style="border: 1px solid black; padding: 2px; margin-right: 10px;">0</div> <div style="display: flex; flex-direction: column; align-items: center;"> <div style="width: 100%; border-bottom: 1px solid black; margin-bottom: 5px;"></div> <div style="width: 100%; border-bottom: 1px solid black; margin-bottom: 5px;"></div> <div style="width: 100%; border-bottom: 1px solid black;"></div> </div> <div style="margin-left: 10px;"> <p>Home position setting type</p> <p>0: Dog type (rear end detection)</p> <p>1: Count type (front end detection)</p> <p>2: Data setting type</p> <p>3: Stopper type</p> <p>4: Servo on position home position (home position ignored)</p> </div> </div> <div style="display: flex; align-items: center;"> <div style="width: 100%; border-bottom: 1px solid black; margin-bottom: 5px;"></div> <div style="width: 100%; border-bottom: 1px solid black; margin-bottom: 5px;"></div> </div> <div style="margin-left: 10px;"> <p>Zeroing direction</p> <p>0: Address increasing direction</p> <p>1: Address decreasing direction</p> </div> <div style="display: flex; align-items: center;"> <div style="width: 100%; border-bottom: 1px solid black; margin-bottom: 5px;"></div> </div> <div style="margin-left: 10px;"> <p>Dog signal input polarity</p> <p>0: Dog signal ON when open</p> <p>1: Dog signal ON when closed</p> </div>	P	0010		0000 to 0114h
		JG2	JOG speed 2 Used to set speed 2 of the jog speed command.	R	1000	r/min	0 to max. speed
	10	ZPS	Zeroing position data Used to set the current position reached on completion of zeroing. The actual zeroing position data is 10STM times greater than the set value.	P	0	Command unit × 10 <sup>STM</sup> × 10 <sup>-3</sup>	-32765 to 32767
	11	ZRF	Zeroing speed Used to set the servo motor speed for zeroing.	P	500	r/min	0 to max. speed
	12	CRF	Creep speed Used to set the creep speed after proximity dog detection.	P	10	r/min	0 to max. speed
	13	ZST	Zero shift distance Used to set the shifting distance from the Z-phase pulse detection position in the encoder.	P	0	Command unit	0 to 65535
	14	DCT	Moving distance after proximity dog signal ON Used to set the moving distance after detection of the proximity dog for count type zeroing. Set the value not less than the distance required to decelerate from the zeroing speed.	P	1000	Command unit × 10 <sup>STM</sup> × 10 <sup>-3</sup>	0 to 65535
	15	STN	Second home position data Used to set the current position reached when automatic zeroing is performed to return to the second home position. The actual second home position data is 10STM times greater than the set value.	P	0	Command unit × 10 <sup>STM</sup> × 10 <sup>-3</sup>	-32768 to 32767
	16	INP	In-position range Used to set the droop pulse range when the in-position signal is output.	P, R	25	pulse	0 to 50000

## 6. PARAMETERS

classification	No.	Code	Name and Function	Feeding system	Initial value	Unit	Setting Range
Basic parameters	17	CRP	<p>Rough match output range</p> <p>Used to set the command distance range in which the rough match output is provided.</p>	P, R	0	Command unit × 10 <sup>STM</sup> × 10 <sup>-3</sup>	0 to 50000
	18	MOD	<p>Analog monitor output</p> <p>Used to set the signal provided to the analog monitor output. (Refer to Section 6.2.3.)</p> <div style="border: 1px solid black; width: 100px; height: 20px; margin: 10px 0; display: flex; justify-content: space-around; align-items: center;"> <span>0</span><span> </span><span>0</span><span> </span> </div> <p style="margin-left: 40px;">↓</p> <p style="margin-left: 40px;">Monitor 2 output selection</p> <ul style="list-style-type: none"> <li>0: Motor speed (±8V/maximum speed)</li> <li>1: Torque (±8V/maximum torque) (Note)</li> <li>2: motor speed (+8V/maximum speed)</li> <li>3: Torque (+8V/maximum torque) (Note)</li> <li>4: Current command output</li> <li>5: Command pulse frequency (±8V/400kpps)</li> <li>6: Droop pulse value 1/1 (±11.6V/2048 pulses)</li> <li>7: Droop pulse value 1/4 (±11.6V/8192 pulses)</li> <li>8: Droop pulse value 1/16 (±11.6V/32768 pulses)</li> <li>9: Droop pulse value 1/32 (±11.6V/65536 pulses)</li> <li>A: Droop pulse value 1/64 (±11.6V/131072 pulses)</li> </ul> <p style="margin-left: 40px;">↓</p> <p style="margin-left: 40px;">Monitor 1 out put selection Items are the same as in monitor 2 output selection.</p> <p style="margin-left: 40px;">Note: Torque limit mode (8V is output at the maximum torque). In the torque control mode, the maximum output (8V) changes according to the setting of parameter No.40.</p>	P, R	0001		0000 to 0909h
	19	DMD	<p>Status display selection</p> <p>Used to choose the status display provided at power-on.</p> <div style="border: 1px solid black; width: 100px; height: 20px; margin: 10px 0; display: flex; justify-content: space-around; align-items: center;"> <span>0</span><span> </span><span>0</span><span> </span> </div> <p style="margin-left: 40px;">↓</p> <p style="margin-left: 40px;">Controller display/external display (valid when rotary switch CS1 is 0) The items are the same as in parameter unit status display at power-on. However, you cannot set F (bus voltage). The display is overridden by the setting of the rotary switch on the controller. When the rotary switch setting is "0", parameter No. 19 is made valid. (Refer to Section 7.5.)</p> <p style="margin-left: 40px;">↓</p> <p style="margin-left: 40px;">Parameter unit status display at power-on</p> <ul style="list-style-type: none"> <li>0: Current position</li> <li>1: Command position</li> <li>2: Command remaining distance</li> <li>3: Override</li> <li>4: Position block number</li> <li>5: Feedback pulse value</li> <li>6: Machine speed</li> <li>7: Droop pulse</li> <li>8: Torque limit command voltage</li> <li>9: Regenerative load factor</li> <li>A: Effective load factor</li> <li>B: Peak load factor</li> <li>C: Within-1-revolution position</li> <li>D: ABS counter</li> <li>E: Servo motor speed</li> <li>F: Bus voltage</li> </ul>	P, R	0000		0000 to 00FEh

# 6. PARAMETERS

classification	No.	Code	Name and Function	Feeding system	Initial value	Unit	Setting Range																																																																																																		
Basic parameters	20	*BLK	Parameter/point table write inhibit Used to limit write of the parameter values and point table data.	P, R	0000		0000 to 0E0Eh																																																																																																		
			<div style="border: 1px solid black; display: inline-block; padding: 2px;">0</div> <div style="border: 1px solid black; display: inline-block; padding: 2px; margin-left: 10px;">0</div> Parameter write is limited. <table border="1" style="margin-top: 10px; width: 100%; border-collapse: collapse;"> <thead> <tr> <th>Set value</th> <th>Operation</th> <th>Parameters No.0 to No.20</th> <th>Parameters No.21 to No.79</th> </tr> </thead> <tbody> <tr> <td rowspan="2">0</td> <td>Reference</td> <td style="text-align: center;">○</td> <td style="text-align: center;">/</td> </tr> <tr> <td>Write</td> <td style="text-align: center;">○</td> <td style="text-align: center;">/</td> </tr> <tr> <td rowspan="2">A</td> <td>Reference</td> <td style="text-align: center;">No.20 only</td> <td style="text-align: center;">/</td> </tr> <tr> <td>Write</td> <td style="text-align: center;">No.20 only</td> <td style="text-align: center;">/</td> </tr> <tr> <td rowspan="2">C</td> <td>Reference</td> <td style="text-align: center;">○</td> <td style="text-align: center;">○</td> </tr> <tr> <td>Write</td> <td style="text-align: center;">○</td> <td style="text-align: center;">/</td> </tr> <tr> <td rowspan="2">E</td> <td>Reference</td> <td style="text-align: center;">○</td> <td style="text-align: center;">○</td> </tr> <tr> <td>Write</td> <td style="text-align: center;">○</td> <td style="text-align: center;">○</td> </tr> </tbody> </table> <p style="margin-top: 10px;">When using the MR-H-D01 option card, the write-enabled range changes as follows:</p> <table border="1" style="margin-top: 10px; width: 100%; border-collapse: collapse;"> <thead> <tr> <th>Set value</th> <th>Operation</th> <th>Parameters No.0 to No.20</th> <th>Parameters No.21 to No.64</th> <th>Parameters No.65 to No.79</th> </tr> </thead> <tbody> <tr> <td rowspan="2">0</td> <td>Reference</td> <td style="text-align: center;">○</td> <td style="text-align: center;">/</td> <td style="text-align: center;">○</td> </tr> <tr> <td>Write</td> <td style="text-align: center;">○</td> <td style="text-align: center;">/</td> <td style="text-align: center;">○</td> </tr> <tr> <td rowspan="2">A</td> <td>Reference</td> <td style="text-align: center;">No.20 only</td> <td style="text-align: center;">/</td> <td style="text-align: center;">/</td> </tr> <tr> <td>Write</td> <td style="text-align: center;">No.20 only</td> <td style="text-align: center;">/</td> <td style="text-align: center;">/</td> </tr> <tr> <td rowspan="2">C</td> <td>Reference</td> <td style="text-align: center;">○</td> <td style="text-align: center;">○</td> <td style="text-align: center;">○</td> </tr> <tr> <td>Write</td> <td style="text-align: center;">○</td> <td style="text-align: center;">/</td> <td style="text-align: center;">/</td> </tr> <tr> <td rowspan="2">E</td> <td>Reference</td> <td style="text-align: center;">○</td> <td style="text-align: center;">○</td> <td style="text-align: center;">○</td> </tr> <tr> <td>Write</td> <td style="text-align: center;">○</td> <td style="text-align: center;">○</td> <td style="text-align: center;">○</td> </tr> </tbody> </table> <p style="margin-top: 10px;">When using the large setting/display unit (MR-PRU02) in the roll feeding system, the point table data is protected.</p> <table border="1" style="margin-top: 10px; width: 100%; border-collapse: collapse;"> <thead> <tr> <th rowspan="2">Set value</th> <th colspan="3">Data Setting</th> </tr> <tr> <th>Position data</th> <th>Speed</th> <th>Acceleration/ deceleration time constant</th> </tr> </thead> <tbody> <tr> <td>0</td> <td style="text-align: center;">○</td> <td style="text-align: center;">○</td> <td style="text-align: center;">○</td> </tr> <tr> <td>A</td> <td style="text-align: center;">/</td> <td style="text-align: center;">/</td> <td style="text-align: center;">/</td> </tr> <tr> <td>B</td> <td style="text-align: center;">○</td> <td style="text-align: center;">○</td> <td style="text-align: center;">○</td> </tr> <tr> <td>C</td> <td style="text-align: center;">/</td> <td style="text-align: center;">/</td> <td style="text-align: center;">○</td> </tr> <tr> <td>D</td> <td style="text-align: center;">/</td> <td style="text-align: center;">○</td> <td style="text-align: center;">/</td> </tr> <tr> <td>E</td> <td style="text-align: center;">○</td> <td style="text-align: center;">/</td> <td style="text-align: center;">/</td> </tr> </tbody> </table> <p style="margin-top: 10px;">Note: ○: Can be set. \: Cannot be set.</p>					Set value	Operation	Parameters No.0 to No.20	Parameters No.21 to No.79	0	Reference	○	/	Write	○	/	A	Reference	No.20 only	/	Write	No.20 only	/	C	Reference	○	○	Write	○	/	E	Reference	○	○	Write	○	○	Set value	Operation	Parameters No.0 to No.20	Parameters No.21 to No.64	Parameters No.65 to No.79	0	Reference	○	/	○	Write	○	/	○	A	Reference	No.20 only	/	/	Write	No.20 only	/	/	C	Reference	○	○	○	Write	○	/	/	E	Reference	○	○	○	Write	○	○	○	Set value	Data Setting			Position data	Speed	Acceleration/ deceleration time constant	0	○	○	○	A	/	/	/	B	○	○	○	C	/	/	○	D	/
Set value	Operation	Parameters No.0 to No.20	Parameters No.21 to No.79																																																																																																						
0	Reference	○	/																																																																																																						
	Write	○	/																																																																																																						
A	Reference	No.20 only	/																																																																																																						
	Write	No.20 only	/																																																																																																						
C	Reference	○	○																																																																																																						
	Write	○	/																																																																																																						
E	Reference	○	○																																																																																																						
	Write	○	○																																																																																																						
Set value	Operation	Parameters No.0 to No.20	Parameters No.21 to No.64	Parameters No.65 to No.79																																																																																																					
0	Reference	○	/	○																																																																																																					
	Write	○	/	○																																																																																																					
A	Reference	No.20 only	/	/																																																																																																					
	Write	No.20 only	/	/																																																																																																					
C	Reference	○	○	○																																																																																																					
	Write	○	/	/																																																																																																					
E	Reference	○	○	○																																																																																																					
	Write	○	○	○																																																																																																					
Set value	Data Setting																																																																																																								
	Position data	Speed	Acceleration/ deceleration time constant																																																																																																						
0	○	○	○																																																																																																						
A	/	/	/																																																																																																						
B	○	○	○																																																																																																						
C	/	/	○																																																																																																						
D	/	○	/																																																																																																						
E	○	/	/																																																																																																						

## 6. PARAMETERS

### (2) Extension parameters

classification	No.	Code	Name and Function	Feeding system	Initial value	Unit	Setting Range																																																							
Extension parameters	21	AUT	<p>Auto tuning Used to set the response, etc. for execution of the auto tuning function.</p> <div style="border: 1px solid black; display: inline-block; padding: 2px;">0 0 0</div> <p>Auto tuning selection 0: Auto tuning selected for use of interpolation axis control, etc. In position control (valid) 1: Auto tuning for ordinary operation (valid) 2: No auto tuning (invalid)</p> <p>Response setting (when auto tuning is valid) Optimum response can be selected according to the rigidity of the machine. As the machine has higher rigidity, faster response can be set to improve tracking performance in response to a command and to reduce setting time.</p> <table border="1" style="width: 100%; border-collapse: collapse;"> <thead> <tr> <th rowspan="2">Machine Type</th> <th rowspan="2">Setting</th> <th colspan="3">Description</th> <th rowspan="2">Guideline for Position Setting Time GDL<sup>2</sup>/GDM<sup>2</sup> guideline = within 5 times</th> </tr> <tr> <th>Response</th> <th>Guideline for corresponding machine rigidity</th> <th>GDL<sup>2</sup>/GDM<sup>2</sup> guideline for load inertia</th> </tr> </thead> <tbody> <tr> <td>Initial value</td> <td>0</td> <td>Low response</td> <td>Low to high rigidity</td> <td>1 to 5 times</td> <td></td> </tr> <tr> <td rowspan="4">Normal</td> <td>1</td> <td>Low response</td> <td>Low rigidity</td> <td rowspan="4">1 to 10 times</td> <td>50 to 300ms</td> </tr> <tr> <td>2</td> <td rowspan="2">Middle response</td> <td>to</td> <td>10 to 70ms</td> </tr> <tr> <td>3</td> <td>Middle rigidity</td> <td rowspan="2">10 to 30ms</td> </tr> <tr> <td>4</td> <td>to</td> <td>High rigidity</td> </tr> <tr> <td>5</td> <td>High response</td> <td></td> <td></td> </tr> <tr> <td rowspan="3">Large friction</td> <td>8</td> <td>Low response</td> <td>Low rigidity</td> <td rowspan="3">1 to 10 times</td> <td>70 to 400ms</td> </tr> <tr> <td>9</td> <td rowspan="2">Middle response</td> <td>to</td> <td>10 to 100ms</td> </tr> <tr> <td>A</td> <td>Middle rigidity</td> <td rowspan="2">10 to 50ms</td> </tr> <tr> <td>B</td> <td>to</td> <td></td> </tr> <tr> <td>C</td> <td>High response</td> <td>High rigidity</td> <td></td> </tr> </tbody> </table> <p>When changing the set value, look at the vibration and setting of the servo motor and machine immediately before they stop and during their stop and always increase the set value in sequence, beginning with the slower response.</p>	Machine Type	Setting	Description			Guideline for Position Setting Time GDL <sup>2</sup> /GDM <sup>2</sup> guideline = within 5 times	Response	Guideline for corresponding machine rigidity	GDL <sup>2</sup> /GDM <sup>2</sup> guideline for load inertia	Initial value	0	Low response	Low to high rigidity	1 to 5 times		Normal	1	Low response	Low rigidity	1 to 10 times	50 to 300ms	2	Middle response	to	10 to 70ms	3	Middle rigidity	10 to 30ms	4	to	High rigidity	5	High response			Large friction	8	Low response	Low rigidity	1 to 10 times	70 to 400ms	9	Middle response	to	10 to 100ms	A	Middle rigidity	10 to 50ms	B	to		C	High response	High rigidity		P, R	0001		0000 to 0C02h
	Machine Type	Setting	Description			Guideline for Position Setting Time GDL <sup>2</sup> /GDM <sup>2</sup> guideline = within 5 times																																																								
Response			Guideline for corresponding machine rigidity	GDL <sup>2</sup> /GDM <sup>2</sup> guideline for load inertia																																																										
Initial value	0	Low response	Low to high rigidity	1 to 5 times																																																										
Normal	1	Low response	Low rigidity	1 to 10 times	50 to 300ms																																																									
	2	Middle response	to		10 to 70ms																																																									
	3		Middle rigidity		10 to 30ms																																																									
	4	to	High rigidity																																																											
5	High response																																																													
Large friction	8	Low response	Low rigidity	1 to 10 times	70 to 400ms																																																									
	9	Middle response	to		10 to 100ms																																																									
	A		Middle rigidity		10 to 50ms																																																									
B	to																																																													
C	High response	High rigidity																																																												
	22	*OP1	<p>Function selection 3 Used to select the optional function.</p> <div style="border: 1px solid black; display: inline-block; padding: 2px;">0 0 0</div> <p>Low acoustic-noise mode selection By selecting the low acoustic-noise mode, electromagnetic noise generated by the servo motor can be reduced approx. 20dB. (Refer to Section 6.2.6.) At this time, the continuous output of the servo motor reduces. (Refer to Section 13.1.) 0: Non-low acoustic-noise 3: Low acoustic-noise mode is selected.</p>	P, R	0000		0000 to 0003h																																																							

## 6. PARAMETERS

Classification	No.	Code	Name and Function	Feeding system	Initial value	Unit	Setting Range				
Extension parameters	23	*OP2	<p>Function selection 4 Used to choose the stop processing to be performed when LSP · LSN signal turns off.</p> <table border="1" style="margin-left: 20px;"> <tr> <td style="width: 20px; text-align: center;">0</td> <td style="width: 20px; text-align: center;">0</td> <td style="width: 20px; text-align: center;"> </td> <td style="width: 20px; text-align: center;">0</td> </tr> </table> <p style="margin-left: 40px;">↓ Stopping pattern when LSP/LSN is switched off (made valid) 0: Sudden stop 1: Slow stop</p>	0	0		0	P, R	0000		0000 to 1011h
	0	0		0							
	24	*OP3	<p>Function selection 5 Used to choose the input filter and override.</p> <table border="1" style="margin-left: 20px;"> <tr> <td style="width: 20px; text-align: center;">0</td> <td style="width: 20px; text-align: center;"> </td> <td style="width: 20px; text-align: center;"> </td> <td style="width: 20px; text-align: center;">0</td> </tr> </table> <p style="margin-left: 40px;">           ↓ External input signal filter            0: Without filter            1: 3.55 [msec]            2: 7.11 [msec]         </p> <p style="margin-left: 80px;">           ↓ Override            0: Invalid            1: Valid         </p> <p style="margin-left: 60px;">} Used to protect the external relay contact input from chattering, noise entry, etc.</p>	0			0	P, R	0000		0000 to 1211h
	0			0							
	25	BKC	<p>Backlash compensation Used to set the backlash compensated for when the command direction is reversed.</p>	P, R	0	pulse	0 to 10000				
	26	FFC	<p>Feed forward gain Used to set the feed forward gain for position control. Set 100% to zero the droop pulse value when operation is performed at constant speed. Note that sudden acceleration/deceleration will increase overshoot. (As a guideline, acceleration/deceleration time up to the rated speed is 1S or longer at the FFC of 100.)</p> <p>When this parameter is set, parameter No.21 must be set to disable auto tuning.</p>	P, R	0	%	0 to 100				
	27	ERZ	<p>Excessive error alarm level Used to set the range in which the excessive droop alarm is provided.</p>	P, R	80	kpulse	1 to 1000				
	28	INT	<p>In-position output time Set the length of time when the in-position signal is kept output. Set "0" to keep outputting the signal during positioning.</p>	P, R	0	ms	0 to 50000				
29	*RMX	For manufacturer setting			0120						
30	RM2	<p>Pulse input function 2 Used to set the pulse magnification of the manual pulse generator (MR-HDP01).</p> <table border="1" style="margin-left: 20px;"> <tr> <td style="width: 20px; text-align: center;">0</td> <td style="width: 20px; text-align: center;">0</td> <td style="width: 20px; text-align: center;">0</td> <td style="width: 20px; text-align: center;"> </td> </tr> </table> <p style="margin-left: 40px;">↓ Manual pulse generator input selection 0: Manual pulse generator input invalid 1: 1-time pulses 2: 10-time pulses 3: 100-time pulses</p>	0	0	0		P, R	0000		0000 to 0003h	
0	0	0									

## 6. PARAMETERS

classification	No.	Code	Name and Function	Feeding system	Initial value	Unit	Setting Range
Extension parameters	31	*DSP	Display function selection Used to choose the display function of the current position. <div style="display: flex; align-items: center; margin-top: 10px;"> <div style="border: 1px solid black; padding: 2px 5px; margin-right: 5px;">0</div> <div style="border: 1px solid black; padding: 2px 5px; margin-right: 5px;">0</div> <div style="border: 1px solid black; padding: 2px 5px; margin-right: 5px;">0</div> <div style="border: 1px solid black; padding: 2px 5px; margin-right: 5px;"> </div> </div> <div style="margin-left: 100px; margin-top: 10px;">           ↓            Current position display function selection            0: Cumulative display            1: Fixed dimension display         </div>	R	0000		0000 to 0001
	32		Spare				
	33						
	34						
	35						
	36						
	37						
	38						
	39	*ENR	Encoder output pulse Used to set the encoder output pulse (A-phase/B-phase) per servo motor revolution. The value (pulses/rev) set in this parameter is output independently of the motor type. The setting is a value derived by multiplying the A-phase/B-phase pulses by 4.	P, R	2048	pulse /rev	0 to 50000
	40	TL1	Internal torque limit value 1 Set to define the maximum torque as 100%. When the external analog torque limit is valid, torque is limited at the lower level value of the external and internal torque limit values. When torque monitoring has been selected for monitor output, this set level is 8[V]. The monitored torque of the analog monitor output is 8[V] at max. torque.	P, R	100	%	0 to 100

# 6. PARAMETERS

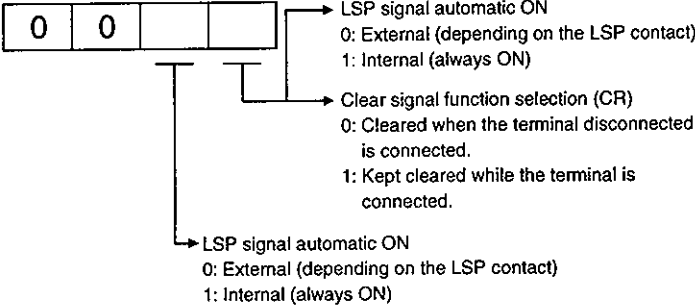
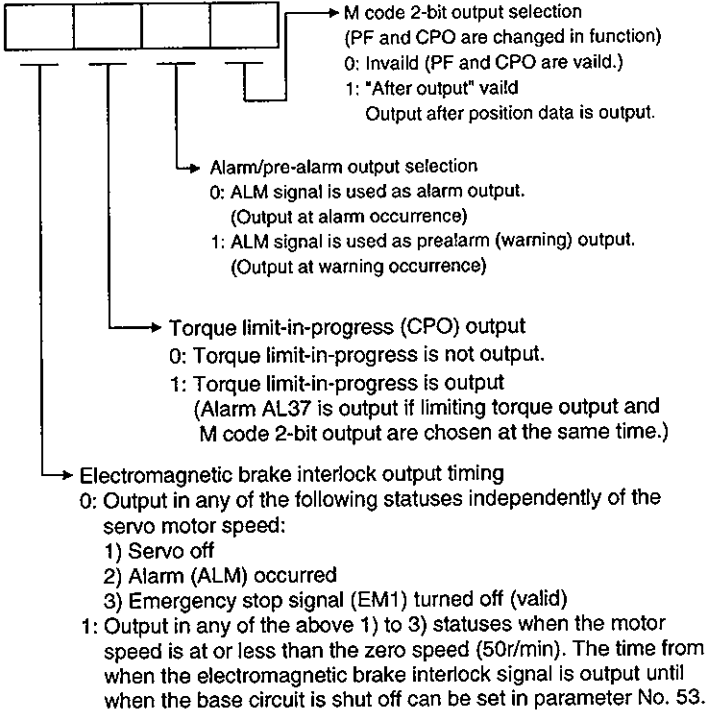

classification	No.	Code	Name and Function	Feeding system	Initial value	Unit	Setting Range
Extension parameters	41	*IP1	<p>Input signal selection 1 Used to select the functions of the input signals.</p> <p>SON signal function selection 0: Servo ON 1: Reset (SON is automatically switched on internally)</p> <p>Torque limit (DI1) switching function selection</p> <p>0: ON The external analog torque limit command is valid. However, the internal torque limit value is valid when the internal torque limit value (parameter No.40) is less than the external torque limit. OFF The internal torque limit value is valid.</p> <p>1: ON The internal torque limit value (parameter No.40) is valid. However, the internal torque limit value 2 is always valid when the internal torque limit value 2 is less than the internal torque limit. OFF The internal torque limit value 2 (parameter No.54) is valid.</p> <p>DI1 signal function selection 0: Torque limit 1: Temporary stop (torque limit 1 (parameter No.40) is always valid)</p>	P	0100		0000 to 0111h
			<p>SON signal function selection 0: Servo ON 1: Reset (SON is automatically switched on internally)</p> <p>Torque limit (LSP) switching function selection</p> <p>0: ON The external analog torque limit command is valid. However, the internal torque limit value is valid when the internal torque limit value (parameter No.40) is less than the external torque limit. OFF The internal torque limit value is valid.</p> <p>1: ON The internal torque limit value (parameter No.40) is valid. However, the internal torque limit value 2 is always valid when the internal torque limit value 2 is less than the internal torque limit. OFF The internal torque limit value 2 (parameter No.54) is valid.</p> <p>LSN signal function selection 0: Torque limit (reverse stroke end is switched on internally) 1: Forward stroke end (torque limit 1 (parameter No.40) is always valid)</p> <p>LSN signal function selection 0: Second feed distance (reverse stroke end is switched on internally) 1: Reverse stroke end (for the feed distance, select position block No.0)</p>	R	0000		0000 to 0011h

## 6. PARAMETERS

classification	No.	Code	Name and Function	Feeding system	Initial value	Unit	Setting Range
Extension parameters	42	*IP2	<p>Input signal selection 2 Used to select the functions of the input signals.</p>  <p>LSP signal automatic ON 0: External (depending on the LSP contact) 1: Internal (always ON)</p> <p>Clear signal function selection (CR) 0: Cleared when the terminal disconnected is connected. 1: Kept cleared while the terminal is connected.</p> <p>LSP signal automatic ON 0: External (depending on the LSP contact) 1: Internal (always ON)</p>	P	0000		0000 to 0011h
	43		Spare				
	44	*OPC	<p>Output signal selection Used to select the functions of the output signals.</p>  <p>M code 2-bit output selection (PF and CPO are changed in function) 0: Invalid (PF and CPO are valid.) 1: "After output" valid Output after position data is output.</p> <p>Alarm/pre-alarm output selection 0: ALM signal is used as alarm output. (Output at alarm occurrence) 1: ALM signal is used as prealarm (warning) output. (Output at warning occurrence)</p> <p>Torque limit-in-progress (CPO) output 0: Torque limit-in-progress is not output. 1: Torque limit-in-progress is output (Alarm AL37 is output if limiting torque output and M code 2-bit output are chosen at the same time.)</p> <p>Electromagnetic brake interlock output timing 0: Output in any of the following statuses independently of the servo motor speed: 1) Servo off 2) Alarm (ALM) occurred 3) Emergency stop signal (EM1) turned off (valid) 1: Output in any of the above 1) to 3) statuses when the motor speed is at or less than the zero speed (50r/min). The time from when the electromagnetic brake interlock signal is output until when the base circuit is shut off can be set in parameter No. 53.</p>	P	0000		0000 to 1111h
45		Spare					

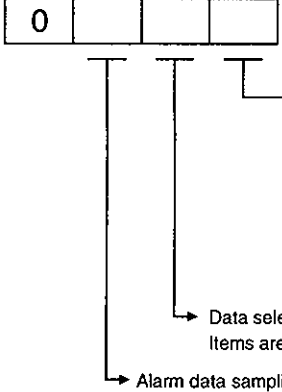

## 6. PARAMETERS

Classification	No.	Code	Name and Function	Feeding system	Initial value	Unit	Setting Range
Extension parameters	46	*MOA	<p>Pre-alarm data selection Used to choose the pre-alarm data to be output.</p>  <p> <b>Data selection 2</b>            0: Servo motor speed (<math>\pm</math>output)            1: Torque (<math>\pm</math>output)            2: Servo motor speed (+output)            3: Torque (+output)            4: Current command output (<math>\pm</math>output)            5: Command pulse frequency            6: Droop pulse value 1/1 (<math>\pm</math>output)            7: Droop pulse value 1/4 (<math>\pm</math>output)            8: Droop pulse value 1/16 (<math>\pm</math>output)            9: Droop pulse value 1/32 (<math>\pm</math>output)            A: Droop pulse value 1/64 (<math>\pm</math>output)         </p> <p> <b>Data selection 1</b>            Items are the same as in data selection 2         </p> <p> <b>Alarm data sampling time selection</b>            0: 3.55 [msec]            1: 7.11 [msec]            2: 14.2 [msec]            3: 28.4 [msec]         </p>	P, R	0001		0000 to 03AAh
	47	VCO	<p>OVR offset Used to set the offset in response to the override command.</p>	P, R	0	mv	-9999 to 9999
	48	TPO	<p>TLAP offset Used to set the offset in response to the torque limit analog command.</p>	P, R	0	mv	-9999 to 9999
	49		Spare				
	50	MO1	<p>MO1 offset Used to set the offset value for the monitor output.</p>	P, R	0	mv	-9999 to 9999
	51	MO2	<p>MO2 offset Used to set the offset value for the monitor output.</p>	P, R	0	mv	-9999 to 9999
	52	*SIO	<p>External digital display (MR-DP60) selection Set this parameter when using the external digital display.</p>  <p> <b>External display selection</b>            0: Encoder pulses (value set in parameter No. 39) are output. (Differential driver)            1: External display is used.         </p>	P, R	0101		0000 to 3101
	53	MBR	<p>Electromagnetic brake sequence output Used to set a time delay between magnetic brake operation and base circuit shut-off.</p>	P, R	100	ms	0 to 1000
	54	TL2	<p>Internal torque limit value 2 Set to define the maximum torque as 100%. Set 0010 in parameter No.41 and switch on the external torque limit signal (P: DI1, R: LSP) to control torque at the value of this parameter. The set value of this parameter should be larger than the internal torque control value in parameter No.40. If smaller, this parameter is made valid Independently of the switching of DI1/LSP.</p>	P, R	100	%	0 to 100
	55		Spare				
56							
57							

## 6. PARAMETERS

classification	No.	Code	Name and Function	Feeding system	Initial value	Unit	Setting Range																		
Extension parameters	58	DG2	Ratio of load inertia moment to servo motor inertia moment Used to set the ratio of the load inertia moment to the servo motor shaft inertia moment. When auto tuning is selected, the result of auto tuning is automatically set.	P, R	2.0		0.0 to 100.0																		
	59	NCH	Machine resonance control filter Used to set the frequency to match the resonance frequency of the mechanical system. <table border="1" data-bbox="405 595 932 904"> <thead> <tr> <th>Set Value</th> <th>Machine Resonance Frequency [Hz]</th> </tr> </thead> <tbody> <tr> <td>0</td> <td>Not used</td> </tr> <tr> <td>1</td> <td>1125</td> </tr> <tr> <td>2</td> <td>563</td> </tr> <tr> <td>3</td> <td>375</td> </tr> <tr> <td>4</td> <td>282</td> </tr> <tr> <td>5</td> <td>225</td> </tr> <tr> <td>6</td> <td>188</td> </tr> <tr> <td>7</td> <td>161</td> </tr> </tbody> </table>	Set Value	Machine Resonance Frequency [Hz]	0	Not used	1	1125	2	563	3	375	4	282	5	225	6	188	7	161	P, R	0		0 to 7
	Set Value	Machine Resonance Frequency [Hz]																							
	0	Not used																							
	1	1125																							
	2	563																							
	3	375																							
4	282																								
5	225																								
6	188																								
7	161																								
60	PG2	Position control gain 2 Used to set the gain of the position loop. Set this parameter to increase the position response level to load disturbance. Higher setting increase the response level but is liable to generate vibration and/or noise. When auto tuning is selected, the result of auto tuning is automatically set.	P, R	25	rad/s	1 to 500																			
61	VG1	Speed control gain 1 Normally this parameter setting need not be changed. Higher setting increases the response level but is liable to generate vibration and/or noise. When auto tuning is selected, the result of auto tuning is automatically set.	P, R	1200	rad/s	2 to 5000																			
62	VG2	Speed control gain 2 Set the parameter when vibration occurs on machines of low rigidity or large backlash. Higher setting increases the response level but is liable to generate vibration and/or noise. When auto tuning is selected, the result of auto tuning is automatically set.	P, R	600	rad/s	2 to 5000																			
63	VIC	Speed integral compensation Used to set the integral time constant of the speed loop. When auto tuning is selected, the result of auto tuning is automatically set.	P, R	20	ms	1 to 1000																			
64	VDC	Speed differential compensation Used to set the time constant of differential compensation. When auto tuning is selected, the result of auto tuning is automatically set.	P, R	980		0 to 1000																			

## 6. PARAMETERS

### (3) Parameters used when the option card (MR-H-D01) is loaded

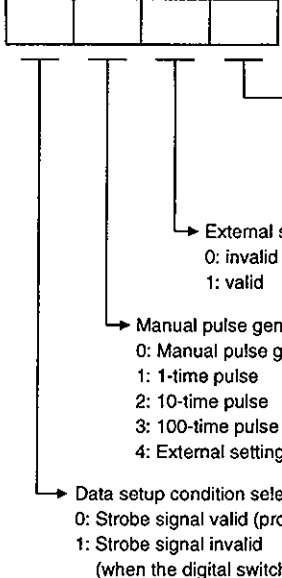
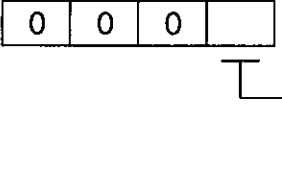
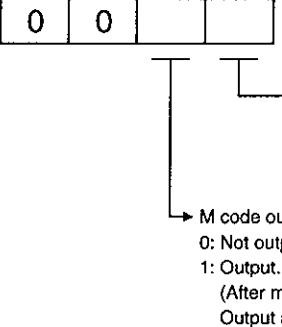
classification	No.	Code	Name and Function	Feeding system	Initial value	Unit	Setting Range
Optional parameters	65	*DI1	<p>Extension function selection 1</p> <p>This parameter must be set when the option card (MR-H-D01) is used.</p>  <p>Feed distance 0: Option card is not used. 1: BCD 3-digits×2 input 3: 256 position blocks selected.</p> <p>Feed distance 0: Option card is not used. 1: BCD 3-digits×2 Input</p> <p>External setting of speed selection 0: invalid 1: valid</p> <p>Manual pulse generator magnification selection 0: Manual pulse generator is not used. 1: 1-time pulse 2: 10-time pulse 3: 100-time pulse 4: External setting of pulse magnification (DI20, DI21 used)</p> <p>Data setup condition selection 0: Strobe signal valid (programmable controller used) 1: Strobe signal invalid (when the digital switch or 256 position blocks are selected)</p>	P	1000		0000 to 1413h
				R			
				P R			
	66	*DI2	<p>Extension function selection 2</p> <p>Set this parameter when using override.</p>  <p>Override selection (DI16) is selected 0: invalid (Not used.) 1: valid (Used.)</p>	P, R	0000		0000 to 0001h
	67	*DOS	<p>Extension function selection</p> <p>Set this parameter when outputting the alarm code and M code.</p>  <p>Alarm code output selection 0: Not output. 1: Output.</p> <p>M code output selection 0: Not output. 1: Output. (After mode) Output after position data is output.</p>	P, R	0000		0000 to 0011h
				P			

## 6. PARAMETERS

classification	No.	Code	Name and Function	Feeding system	Initial value	Unit	Setting Range
	68	*APS	For manufacturer setting	P, R	0120		
	69		Spare				
	70						
	71						
	72						
	73						
	74						
	75						
	76						
	77						
	78						
	79						

## 6. PARAMETERS

### 6.2 Detailed Explanation

#### 6.2.1 Electronic gear

POINT
<ul style="list-style-type: none"> <li>The electronic gear setting range is <math>\frac{1}{50} &lt; \frac{CMX}{CDV} &lt; 50</math>.</li> <li>If the setting is outside this range, operation may not be performed at the preset speed and/or acceleration/deceleration time constants.</li> </ul>

Use the electronic gear (parameters No.5, 6) to make adjustment so that the controller setting matches the moving distance of the machine. Also, by changing the electronic gear value, the machine can be moved at any multiplication ratio to the moving distance on the controller.

$$\frac{CMX}{CDV} = \frac{\text{Parameter No.5}}{\text{Parameter No.6}}$$

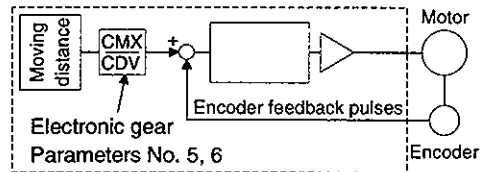

The following examples are used to explain how to calculate the electronic gear value:

#### (1) Ballscrew setting example

Machine specifications

Ballscrew lead :  $P_b = 10$  [mm]

Reduction ratio :  $n = 1/2$

Servo motor resolution :  $P_t = 8192$  [pulse/rev]

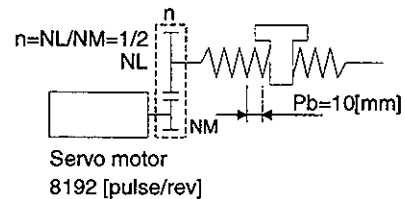

$$\frac{CMX}{CDV} = \frac{P_t}{\Delta S} = \frac{P_t}{n \cdot P_b \cdot 1000} = \frac{8192}{1/2 \cdot 10 \cdot 1000} = \frac{8192}{5000} = \frac{1024}{625}$$

Hence, set 1024 to CMX and 625 to CDV.

#### (2) Conveyor setting example

Machine specifications

Pulley diameter :  $r = 10$  [mm]

Reduction ratio :  $n = 1/3$

Servo motor resolution :  $P_t = 16384$  [pulse/rev]

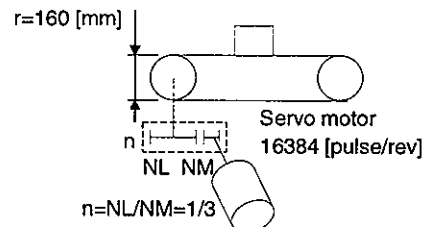

$$\frac{CMX}{CDV} = \frac{P_t}{\Delta S} = \frac{P_t}{n \cdot r \cdot \pi \cdot 1000} = \frac{16384}{1/3 \cdot 160 \cdot \pi \cdot 1000} = \frac{16384}{167551.61} = \frac{4096}{41888} = \frac{2048}{20944}$$

Reduce CDV to 50000 or less and round off the first decimal place.

Hence, set 2048 to CMX and 20944 to CDV.

## 6. PARAMETERS

### 6.2.2 Changing the status display screen

By changing the parameter No.19 value, you can change the status display item of the controller display section or MR-DP60 with CS1 = 0 and that of the parameter unit at power-on. In the initial status, each display shows the current position.

For display details, refer to Section 7.3.

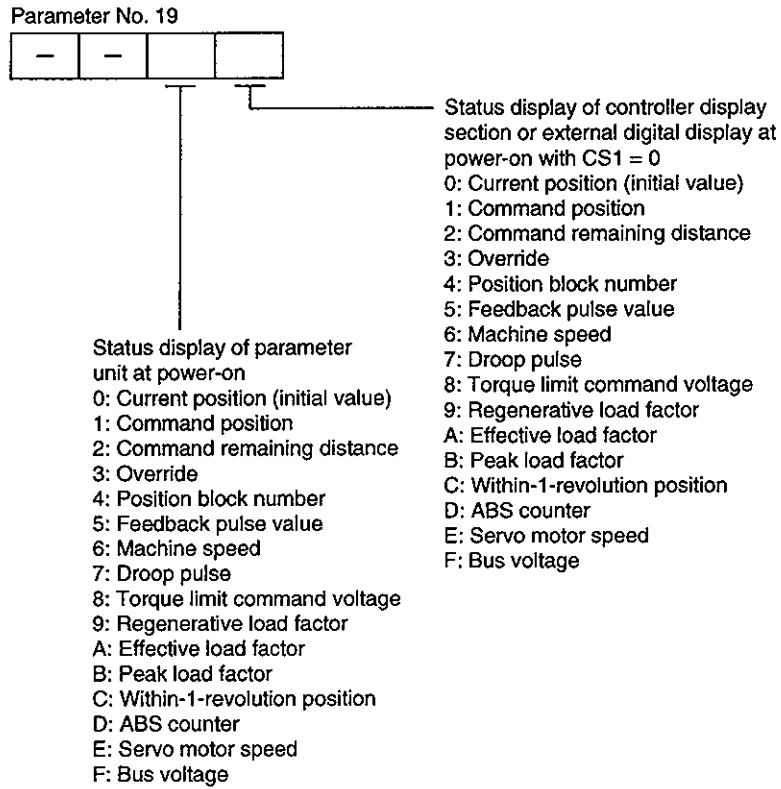

## 6. PARAMETERS

### 6.2.3 Analog output

The servo status can be output to two channels in terms of voltage. Use this function when using an ammeter to monitor the servo status or synchronizing the torque/speed with the other servo.

The servo amplifier is factory-set to output the motor speed to CH1 and the generated torque to CH2. The setting can be changed as listed below by changing the parameter No.18 value:

Setting	Output Item	Description	Setting	Output Item	Description
0	Motor speed		6	Droop pulses 1/1 (2048pulse)	
1	Generated torque		7	Droop pulses 1/4 (8192pulse)	
2	Motor speed		8	Droop pulses 1/16 (32768pulse)	
3	Generated torque		9	Droop pulses 1/32 (65536pulse)	
4	Current command (Torque command)		A	Droop pulses 1/64 (131072pulse)	
5	Command speed				

## 6. PARAMETERS

Change the following digits of parameter No.18:

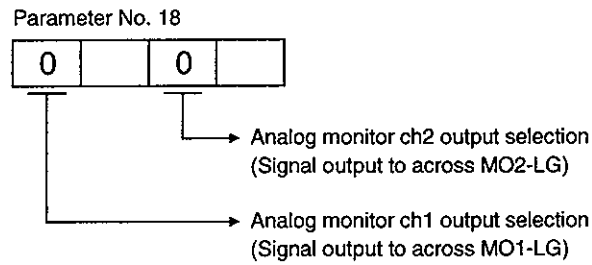

Parameters No.50 and 51 can be used to set the offset voltages to the analog output voltages. The setting range is between  $-9999$  to  $9999$ mV.

Parameter	Description	Setting Range [mV]
Parameter No.50	Used to set the offset voltage for the analog monitor CH1 output.	-9999 to 9999
Parameter No.51	Used to set the offset voltage for the analog monitor CH2 output.	

### 6.2.4 Changing the stopping pattern at the forward/reverse stroke end

The motor stops when LSP-SG are opened during forward rotation. It may be run in the reverse rotation direction. The motor stops when LSN-SG are opened during reverse rotation. It may be run in the forward rotation direction.

The stopping method can be changed by changing the parameter No.23 value as indicated below:

Parameter No. 23 Setting	Stopping Method
□□0□ (initial value)	Sudden stop Droop pulse value is reset to make a stop.
□□1□	Slow stop Droop pulses are issued to make a slow stop.

### 6.2.5 Rough match output

Rough match (CPO) is output when the command remaining distance reaches the value set in parameter No.17. The set remaining distance is 0 to 50000 [ $\times 10^{\text{STM}}$ mm].

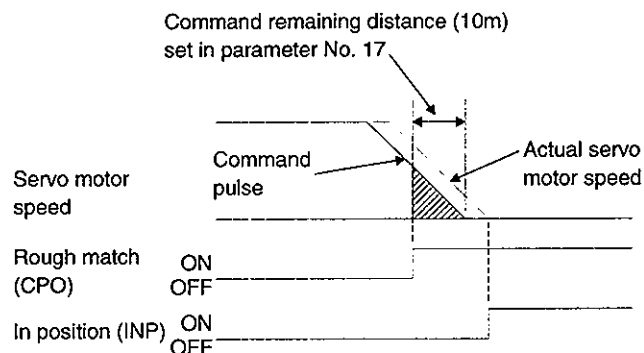



## 6. PARAMETERS

---

### 6.2.6 Low acoustic noise mode

By selecting the low acoustic noise mode in parameter No.22, audible-frequency magnetic noise generated by the servo motor can be improved about 20dB.

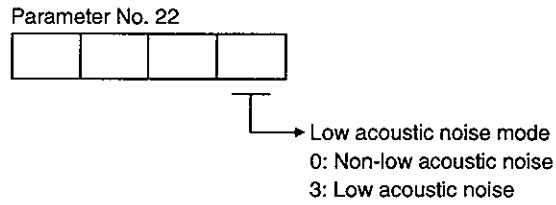

For HC-SF152

